



SOUL

FEATURES & FUNCTIONS GUIDE

www.kia.com

Consumer - Roadside Assistance

1-800-333-4KIA (4542)

See Back Cover for Vehicle Maintenance Schedule

Always check the Owner's Manual for complete operating information and safety warnings.

GETTING TO KNOW YOUR **SOUL**

Congratulations on Your New Kia Purchase!

Your new Kia vehicle has been designed, engineered and manufactured to provide you with years of comfortable and dependable driving. Kia is committed to quality, innovation, safety and — above all — your satisfaction.

Using This Guide

The information contained in this guide is a brief overview that will help you become familiar with the operation and features of your new Kia vehicle. The flipbook format facilitates information access, while the detailed illustrations help to ensure the instructions are easy to follow.

This Features & Functions Guide and the specific operational and safety information it provides is not a substitute for your Owner's Manual. In the interest of your safety and that of your family, and to help you avoid risks that may result in death or serious injury, Kia reminds you to carefully read your Owner's Manual in order to fully familiarize yourself with the important information it contains.

While the information contained in this guide is accurate at the time of printing, Kia may change vehicle specifications without notice in advance or after the fact, and assumes no liability in connection with such changes.

ESSENTIAL FEATURES

Air Conditioning / Climate Control*	24
Active ECO System*	09
Audio System – Standard*	20
Audio System - UVO eServices System*	21
Audio System - Navigation System*	22
Aux/USB/iPod® Port & Power Outlets	23
Bluetooth® Wireless Technology	18
Cruise Control*	17
Digital Clock	23
Folding Rear Seatback	31
ISG (Idle, Stop, Go) System*	10
Manual Gear Shift*	27
Passenger Airbag Off Indicator	39
Tire Mobility Kit	36
Tire Pressure Monitoring System (TPMS)	05
Windshield/Rear Wipers & Washers*	15

Driving while distracted can result in a loss of vehicle control that may lead to an accident, severe personal injury and death. The driver's primary responsibility is in the safe and legal operation of a vehicle, and use of any handheld devices, other equipment or vehicle systems which take the driver's eyes, attention and focus away from the safe operation of a vehicle or that are not permissible by law should never be used during operation of the vehicle.



SOUL FEATURES & FUNCTIONS GUIDE

VIDEOS & QR CODES	02
-------------------	----

INSTRUMENT CLUSTER

Instrument Cluster Overview	03
Indicators & Warning Lights	04
Tire Pressure Monitoring System (TPMS)	05
Fuel Economy	05
Trip Computer* / Tripmeter	06
LCD Instrument Cluster Modes*	06
User Settings Mode*	07
Service Mode*	07
Active ECO System*	08

DRIVER'S PANEL

Instrument Panel Dimmer	09
Electronic Stability Control (ESC)	09
Hill-Start Assist Control	09
ISG (Idle, Stop, Go) System*	10
Power Windows, Window Lock & Central Door Lock	11
Automatic Door Lock/Unlock	11
Heated Outside Mirrors*	11
Power Outside Mirrors*	11
Engine Start/Stop Button*	12

STEERING WHEEL CONTROLS

Tilt/Telescoping Steering Wheel	13
Heated Steering Wheel Button*	13
Headlights & High Beams	14
Turn Signals & Fog Lights*	14
Windshield Wipers & Washers	15
Rear Wiper & Washer*	15
FlexSteer™ Steering Wheel Mode	16
Audio Controls	17
Cruise Control*	17
Bluetooth® Wireless Technology	18

AUDIO SYSTEM

Standard Audio System*	20
UVO eServices System*	21
Navigation System*	22
Advanced (Mood) Lighting Speaker*	23

CENTER PANEL

Digital Clock	23
Aux/USB/iPod® Port	23
Power Outlets	23
Automatic Climate Control*	25
Manual Climate Control*	26
Automatic Gear Shift with Sportmatic® Shifting*	26
Manual Gear Shift*	27

SEATING

Seat Warmers / Ventilated Seats*	28
6-Way Manual Adjustable Driver's Seat	28
Power Adjustable Driver's Seat*	29
Front Seat Headrest Adjustment	29
Folding Rear Seatback	30

OTHER KEY FEATURES

Smart Key*	31
Remote Keyless Entry* (Folding Key)	32
Double-Turn Lock/Unlock All	32
Fuel Cap / Malfunction Indicator	32
Map/Room Lamps	33
Sunvisor	33
Panoramic Sunroof Operation*	34
Rear-Camera Display*	35
Hood Release Lever and Latch	36
Fuel Door Release Lever	36
Tire Mobility Kit	36
Rear Hatch Release Button	37
Child Safety Locks	37

SAFETY FEATURES

Seat Belts	38
Seat Belt Retractor Locks	38
Occupant Detection System (ODS) / Passenger Airbag Off Indicator	39

LEGAL DISCLAIMERS (See Back Inside Cover Page)

MAINTENANCE (See Back Cover)

*IF EQUIPPED

Kia provides a number of video resources at your disposal to assist you with becoming familiar with the features and functions found in your Kia vehicle. You can access these resources by snapping the QR Codes with your smartphone/tablet (mobile devices) or by visiting the following website: www.KuTechVideos.com/ps13/2015. Continue reading for a more in-depth look at QR Codes and for instructions on how to use them.

What are QR Codes?

A QR Code is a square, 2-dimensional barcode that can be read by mobile devices loaded with an appropriate barcode or QR Code Reader App. The app reads the barcode image and then launches/uploads the specific information the code contains, such as URLs, text, photos, videos and so much more.

How to use QR Codes

If you have a mobile device with a QR Code Reader App, you can snap the code with your phone and you'll be provided a video with additional information pertaining to the topic. For example, in the Fuel Cap section, if you would like additional information, just snap the code with your mobile device to view the selected Kia Features & Functions Video.

How to snap a QR Code

1. With your mobile device, download a QR Code Reader App. With many devices, you can do this through an app store or marketplace
2. Open the QR Code Reader App on your mobile device
3. The app will utilize your device's camera. Center the code in the camera viewing area:
 - With some apps, as soon as the app recognizes the code, it will launch the corresponding video
 - With other apps, you will have to snap or take a picture of the code. The app will then launch the corresponding video
 - For operation specifics, refer to the instructions that come with the QR Code Reader App

QR CODE

One-Click Fuel Cap Video

To view a video on your mobile device, snap this QR Code or visit the listed website.



www.KuTechVideos.com/ps13/2015

REMINDER: When accessing videos on your mobile device, standard cellular data rates may apply.

© QUICK TIPS

1. If you're having trouble scanning codes, check the following:
 - The code should be centered and focused in your mobile device's camera screen
 - Consider moving your device closer to or farther away from the code
 - The code should be well-lit, without significant shadow
 - Avoid scanning from a significant angle
 - Confirm that the device's app supports 2D QR Code scanning
 - Try another QR Code Reader App; not all apps are created equal
2. After scanning, if a "connecting" message appears and then nothing happens or there's a "connection error" message, this typically indicates that your device is having trouble connecting to the Internet
3. When accessing videos on your mobile device, standard cellular data rates will apply

Instrument Cluster Overview

(Type A)

- A** Tachometer
- B** Speedometer
- C** Turn Signal Indicators
- D** Gear Shift Position
- E** Odometer
- F** Tripmeter
- G** Engine Temperature
- H** Fuel Gauge
- I** Exterior Temperature

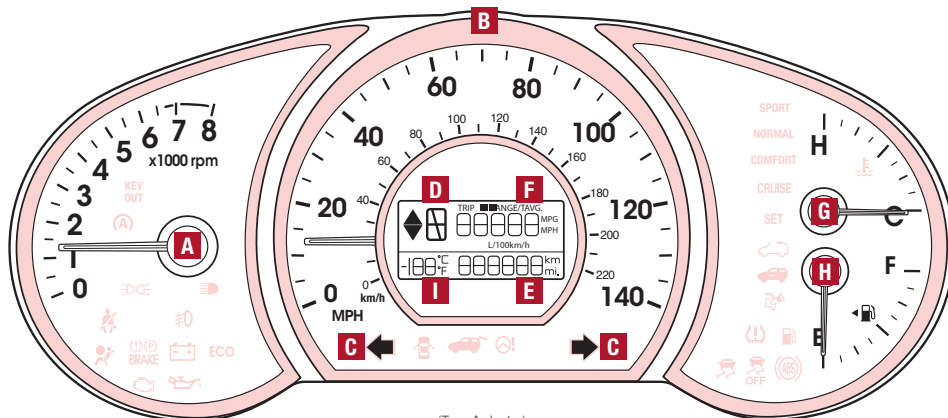

(Type A cluster)

REMINDER: Your vehicle's instrument cluster & indicator light locations may differ from those in the illustrations. See your Owner's Manual for more details.

🔗 QUICK TIPS

For more information on the function of all indicator and warning lights, please refer to the Owner's Manual.

Indicators & Warning Lights







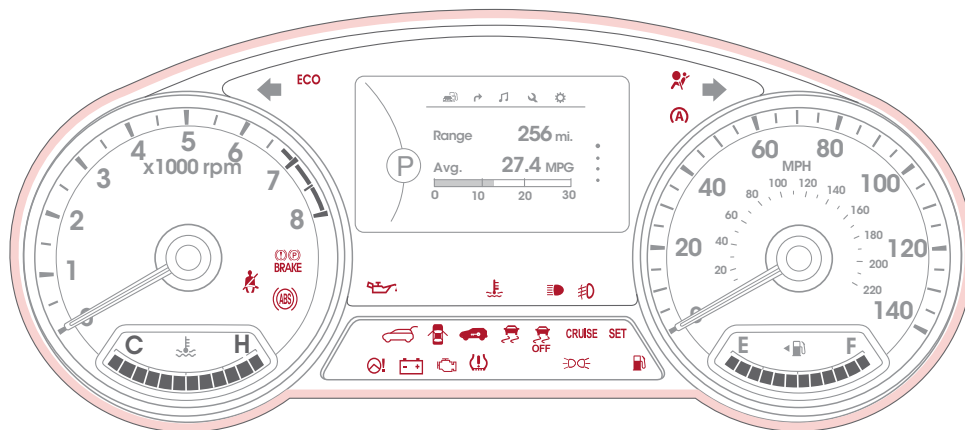

















REMINDER: Your vehicle's instrument cluster and indicator light locations may differ from those in the illustrations. See your Owner's Manual for more details.

QUICK TIPS

For more information on the function of all indicator and warning lights, please refer to the Owner's Manual.



(Type B cluster)

- | | | | | | |
|---|--|---|--|---|--|
|  | Seat Belt Warning Light |  | Door Ajar Warning Light |  | Tail Light Indicator* |
|  | Electronic Brake-Force Distribution (EBD) System Warning Light |  | Fuel Cap / Malfunction Indicator (Check Engine Light) |  | Front Fog Light Indicator* |
|  | Parking Brake & Brake Fluid Warning Light |  | Immobilizer Indicator Light* |  | Cruise ON/OFF Indicator* |
|  | Anti-lock Braking System (ABS) Warning Light |  | Low Tire Pressure Light / Tire Pressure Monitoring System (TPMS) Malfunction Indicator |  | Cruise SET Indicator* |
|  | Active ECO Indicator* |  | Engine Coolant Temperature Warning Light |  | Low Fuel Level Warning Light |
|  | Engine Oil Pressure Warning Light |  | Electronic Stability Control (ESC) Indicator |  | Airbag Warning Light |
|  | Electronic Power Steering Warning Light |  | Electronic Stability Control (ESC) OFF Indicator* |  | Auto Stop (ISG System) Indicator |
|  | Tailgate Open Warning Light |  | High Beam Indicator |  | Fuel Cap Open Warning Indicator (In cluster type B. displays in LCD) |
|  | Charging System Warning Light | | | | |

Tire Pressure Monitoring System (TPMS)



The indicator  functions as both Low Tire Pressure Light and TPMS Malfunction Indicator.

The TPMS indicator illuminates if one or more tires is significantly underinflated, the vehicle has a spare tire installed without TPMS or the outside temperature becomes significantly lower.

Inflate tire(s) to specifications using an accurate digital tire pressure gauge to turn off Low Tire Pressure Light . See front driver's door jamb for PSI specification.

When there is a problem with the TPMS, the TPMS Malfunction Indicator  will blink for approximately one minute and then illuminate - See dealer for service.

REMINDER: Consult your dealer for service if the Low Tire Pressure Light remains illuminated after inflating your tire(s).

Ⓢ QUICK TIPS

- Even with TPMS, tire pressure should be checked manually at least once a month. Only adjust Tire Pressure on "cold tires"
- For proper maintenance and optimal fuel economy, maintain recommended tire inflation pressures and stay within the load limits and weight distribution recommended for your vehicle
- In winter or cold weather, the TPMS light may illuminate if the tire pressure was adjusted to the recommended tire inflation pressure during warm weather

Fuel Economy

There are several factors that contribute to your vehicle's fuel economy, including maintenance of your vehicle, driving style, environmental conditions, vehicle weight and vehicle aerodynamics. Below are tips on how to help improve fuel economy:

- Keep your vehicle in good condition with regular maintenance
- Don't let the engine idle longer than necessary
- Drive at a moderate speed, accelerating smoothly and at a moderate rate
- Keep tires inflated to the recommended pressure
- Travel lightly, without carrying unnecessary weight in your vehicles
- Avoid placing large or heavy items on roof racks
- Avoid hilly, winding or poorly maintained roads

REMINDER: Driving range varies depending on a vehicle's fuel tank size, e.g., 12-gal.vs.24-gal. Even though the two vehicles, MPG may be the same, the vehicle with the larger tank will have the greater range.

For more information on Fuel Economy, you can snap the QR code to view a video or refer to the brochure, "Getting More Out Of Every Gallon, Fuel-Saving Tips To Drive By" available at your local dealership.

📱 QR CODE

To view these videos on your mobile device, snap these QR Codes or visit the listed website.

Refer to page 2 for more information.

Fuel Economy Video



www.KuTechVideos.com/ps13/2015

Tire Pressure Monitoring System



www.KuTechVideos.com/ps13/2015

Trip Computer* / Tripmeter

The Trip Computer is a driver information system that displays information related to driving — such as Odometer, Tripmeter, Range, Average Fuel Consumption and Driving Time — on the display when the ignition switch is in the ON position.

To cycle through the LCD Display modes, press the Mode/Select button **A**.

When in the Trip Computer mode , press the Move/Reset button **B** to cycle through the screens. When displaying Trip A or Trip B screens, press and hold the Move/Reset button **B** to reset the Tripmeter to zero.

REMINDERS:

- Appearance of Tripmeter display may differ as equipped
- All stored driving information (except Odometer and Range) is reset if the battery is disconnected

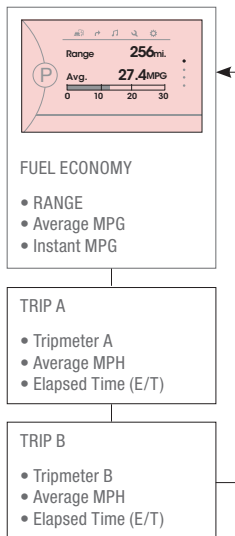

(Type B Cluster)

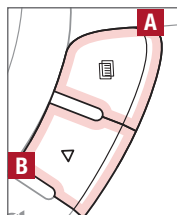

(Buttons located on Steering Wheel)

LCD Instrument Cluster Modes*

(Type B cluster only)

To cycle through the LCD Instrument Cluster modes, press the Mode/Select button **A**.

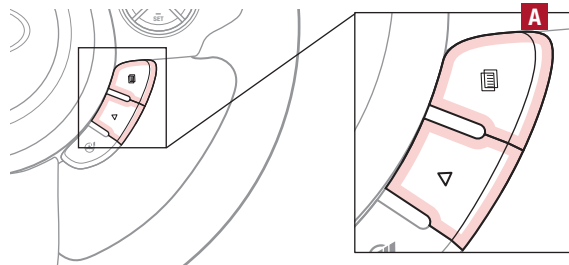

(LCD Instrument Cluster mode buttons located on Steering Wheel)



Trip Computer Mode: Displays driving information for tripmeter, fuel economy, etc.



Turn-by-Turn Mode*: Displays the state of the Navigation system



A/V Mode*: Displays the state of the A/V System



Master Warning / Service Modes: Informs on upcoming service intervals, and warning messages related to TPMS and others



User Settings Mode: Change settings of the doors, lamps and other features

User Settings Mode*

To enter the User Settings mode in the LCD Instrument Cluster Modes, press the Mode/Select button **A** when the vehicle is at a standstill and with the ENGINE START/ STOP button in the ON position and select User Settings .

You can navigate the selections on the display by pressing the Move/Reset button **B**, and then selecting the item by pressing the Mode/Select button **A**.

Door:

- Auto Door Lock & Unlock*
- Two Press Unlock*
- Horn Feedback*

Lamp:

- One-Touch Turn Lamp*
- Headlamp Delay*

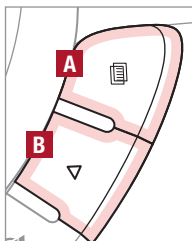

(Buttons located on Steering Wheel)

Settings:

- Language
- Temperature Unit
- AVG Fuel Economy Reset
- Welcome Sound

Service Interval:

- ON/OFF
- Set mileage/months

Service Mode

To enter Service Mode, press the Mode/Select button **A**, scroll to Service Mode  by pressing Move/Reset button **B**. Then press the Mode/Select button **A** to enter. System will display number of miles remaining until next service is due, and type of service.

When service is required, the following will be displayed:
Service Required.

To reset the Service Mode system, press and hold the Move/Reset button **B** for more than 1 second.

To turn **Service In** OFF, go to User Settings.

Service Interval Setting

To set the service interval when in User Settings mode:

- Press the Move/Reset button **B** and scroll to Service Interval. Press the Mode/Select button **A** to enter
- Press the Move/Reset button **B** and toggle to ON, then press the Move/Select button **A**. Then press the Move/Reset button **B** to scroll and select the desired miles or months for your next service
- Press the Mode/Select button **A** to enter

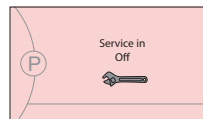
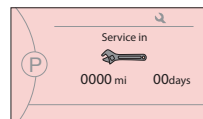

(Instrument cluster LCD screen shown)

QR CODE

To view these videos on your mobile device, snap these QR Codes or visit the listed website.

Refer to page 2 for more information.

LCD Display Video



www.KuTechVideos.com/ps13/2015

LCD Display: Maintenance Video



www.KuTechVideos.com/ps13/2015

Active ECO System*

Active ECO helps improve fuel economy by controlling several vehicle components. When activated, it optimizes drivetrain operations such as engine power and transmission to help improve fuel economy.

To turn ON, press the Active ECO button **B**. The green ECO indicator light **A** in the instrument cluster will illuminate, indicating that Active ECO is operating. The Active ECO System will remain on even when the ignition is cycled.

To turn Active ECO OFF, press the button **B** again.

© QUICK TIPS

To help improve your fuel efficiency:

- Drive at a moderate speed, accelerating smoothly and at a moderate rate
- Keep tires inflated to the recommended pressure
- Be sure the wheels are properly aligned

For more information on the Active ECO System, refer to your Owner's Manual or contact your local dealership.

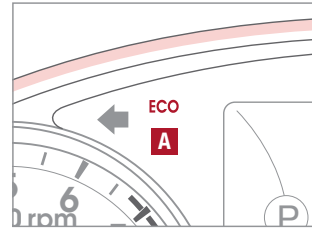

(Type B cluster)

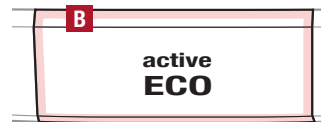

(Button located on Center Panel)

QR CODE

Active ECO Indicator Video

To view a video on your mobile device, snap this QR Code or visit the listed website.

Refer to page 2 for more information.



www.KuTechVideos.com/ps13/2015

Instrument Panel Dimmer

With parking lights / headlights ON, press button **A** + or – to adjust display brightness of the instrument panel illumination.

REMINDERS:

- Door Mood Lamp is a fixed brightness and cannot be adjusted (not to be confused with Advanced Mood Lighting Speaker)
- The Instrument Panel Dimmer does not adjust brightness on the Navigation System* screen; use Navigation setup to adjust brightness on the Navigation System.

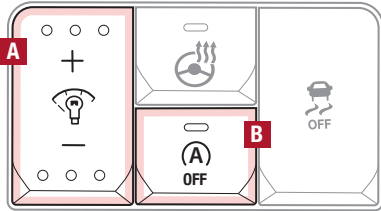

(Buttons located on left side of Driver's Panel)

ISG (Idle, Stop, Go) System*

The ISG system helps reduce fuel consumption by automatically shutting down the engine when the vehicle is at a standstill.

When the vehicle is at a standstill, the engine will stop and the green AUTO STOP indicator (A) on the instrument cluster will illuminate and the message Auto Stop will appear in the LCD screen*.

When ISG mode is ON, the engine will restart when the brake pedal is released or the shift lever is moved to the R (Reverse) position or to Sport mode. When engine restarts, the green AUTO STOP indicator (A) on the instrument cluster will turn off.

To deactivate the ISG System, press the ISG OFF button **B**. If you press again, the system will be activated.

The ISG system is disabled when:

- A seat belt is unfastened
- The hood or a door is opened
- Battery condition is poor
- The front or rear defroster is turned on
- Engine coolant temperature is low
- The outside ambient temperature is too low/high
- Emission control devices activate
- The vehicle is on a steep slope

REMINDERS:

- ISG System is ON at vehicle start up
- Under certain conditions, the engine will restart automatically
- If the AUTO STOP indicator is illuminating yellow, please contact an authorized Kia dealer

QR CODE

ISG (Idle, Stop, Go) System Video

To view a video on your mobile device, snap this QR Code or visit the listed website.

Refer to page 2 for more information.



www.KuTechVideos.com/ps13/2015

For more information on the ISG System, please refer to your Owner's Manual or contact your local dealership.

Electronic Stability Control (ESC)

The ESC system is designed to help stabilize the vehicle during cornering maneuvers. It is a good idea to keep the ESC turned ON for daily driving whenever possible.

Press ESC button **A** to turn ESC OFF/ON.

REMINDERS:

- ESC is turned ON at vehicle start-up
- The ESC Indicator Light in the instrument cluster will be lit momentarily whenever the ESC is active

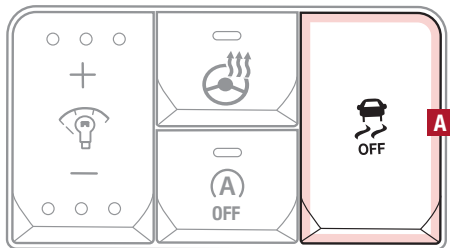

(Buttons located on left side of Driver's Panel)

Hill-Start Assist Control (HAC)

HAC helps prevent the vehicle from rolling backward when accelerating from a stop while on a steep incline. The HAC automatically activates whether the ESC is OFF or ON, but does NOT activate when the ESC has malfunctioned.

REMINDER: The HAC does not operate when the gear shift is in the P (Park) or the N (Neutral) position.

Ⓢ QUICK TIPS

- HAC provides a 2-second delay before the vehicle may start rolling backwards
- When HAC is active (e.g., accelerating from a stop on an incline), you may notice that the brakes will momentarily remain engaged after you depress the accelerator

Power Windows, Window Lock & Central Door Lock

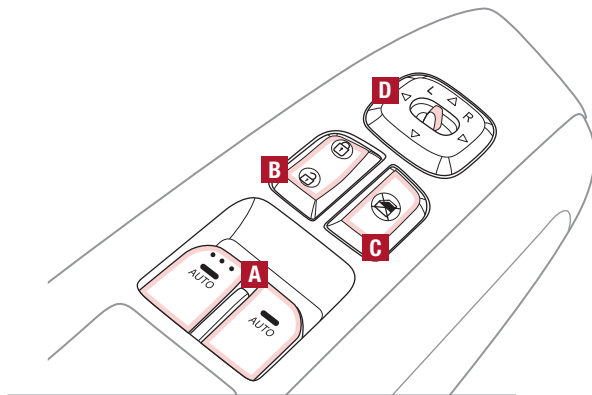

A Pull/Press to operate Driver's and Front Passenger's window Auto Up/Down

B Press to Unlock/Lock All Doors

C Press to disable Rear Passenger Windows

REMINDER: When button **C** is pressed, window controls for the Rear Passenger Windows are disabled.

Automatic Door Lock/Unlock

Auto Door Lock/Unlock will engage when the gear shift is moved in to or out of the P (Park) position. Refer to the User Settings in the LCD Instrument Cluster modes on how to turn Auto Door Lock/Unlock ON/OFF.

Heated Outside Mirrors*

Mirror heaters controlled with Rear Defroster.

Power Outside Mirrors*

Toggle switch **D** left or right to select mirror. Then press arrows to adjust mirror position.

REMINDEERS: To lock position of mirrors, toggle switch to the neutral (center) position.

Engine Start/Stop Button*

To start the engine:

1. Depress the brake pedal
2. Press the ENGINE START/STOP button while gear shift is in P (Park)

To turn the engine OFF – Press the ENGINE START/STOP button again.

To use the ENGINE START/STOP button, you must have the Smart Key fob on your person or inside the vehicle.

REMINDERS:

- In an emergency situation while the vehicle is in motion, you are able to turn the engine off and to the ACC position by pressing the ENGINE START/STOP button for more than 2 seconds or 3 times successively within 3 seconds
- If the Smart Key fob battery is dead, hold the fob up against the Engine Start/Stop button

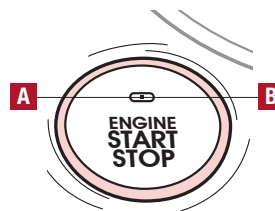

(Button located on right side of Driver's Panel)

Ⓢ QUICK TIPS

To use electrical accessories:

ACC position

- When in the OFF position (no light) and without depressing the brake pedal, press the ENGINE START/STOP button once (amber light **A**)

On position

- When already in the ACC position (amber light **A**), and without depressing the brake pedal, press the ENGINE START/STOP button again (reddish-orange light **B**)
- When in the OFF position (no light) and without depressing the brake pedal, press the ENGINE START/STOP button twice (reddish-orange light **B**)

Keeping the vehicle in ACC or the ON position without driving may discharge the vehicle's battery.

QR CODE

Engine Start/Stop Button & Smart Key Video

To view a video on your mobile device, snap this QR Code or visit the listed website.

Refer to page 2 for more information.



www.KuTechVideos.com/ps13/2015

Tilt/Telescoping Steering Wheel

To adjust the Steering Wheel, push down the lock-release lever **A** and adjust to desired angle **B** and distance **C**.

When finished, pull up the lock-release lever **A** to lock Steering Wheel in place.

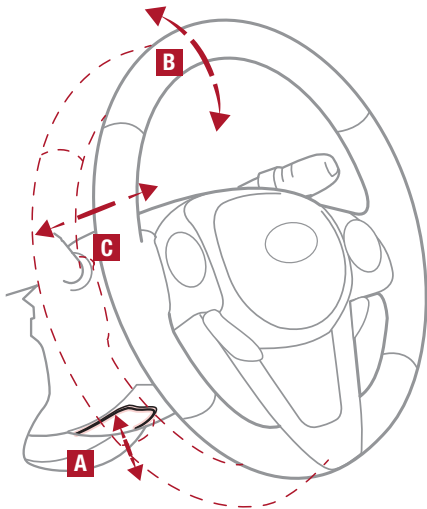

Heated Steering Wheel Button*

Press button **A** to turn ON/OFF steering wheel heater, while the Engine Start/Stop Button is in the ON position. Steering wheel heater will turn off automatically in 30 minutes, or when button is pressed again to deactivate.

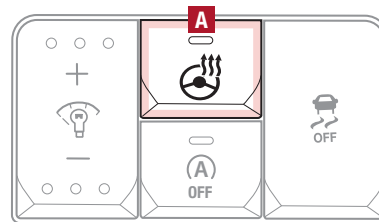

(Buttons located on left side of Driver's Panel)

© QUICK TIPS

If ignition is turned OFF, then ON again, within 30 minutes of steering wheel heater being turned on, system will automatically be set ON again.

Headlights & High Beams

To operate:

- Rotate lever to change the Headlight function
- Push lever to turn High Beams ON
- Pull lever to flash Headlights / High Beams

AUTO Light* function — When the light switch is in the AUTO light position, the tail lights and headlights will turn ON/OFF automatically, depending on the amount of light outside the vehicle.

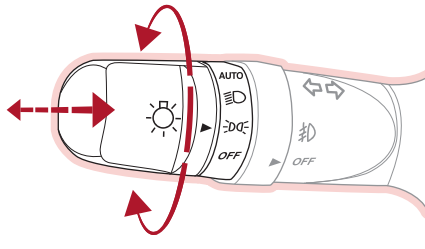

- AUTO* Automatic Headlights position
- ☹️ Headlight position
- ☹️ Parking Light position
- OFF OFF position

Turn Signals & Fog Lights*

To operate:

- Turn Signals - Move lever Up/Down for Right/Left Turn Signal
- Rotate lever ring to turn Fog Lights ON/OFF

One-Touch Lane Change Signal is activated by moving the Turn Signal Lever slightly for less than 1 second and then releasing. The lane change signal will blink 3 times.

To change how many times the Lane Change Signal blinks (3/5/7), go to User Settings Mode* in the LCD Instrument Cluster modes (Type B cluster).

For more information on the User Settings Mode, please refer to your Owner's Manual.

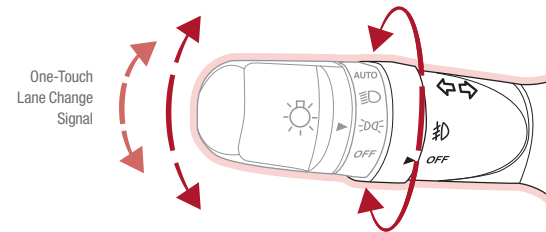

REMINDER: Headlights must be ON for Fog Light operation.

Windshield Wipers & Washers

To operate:

- Move lever Up/Down to change Wiper modes
- Rotate lever to adjust Intermittent Wipe Speed
- Pull to spray and wipe

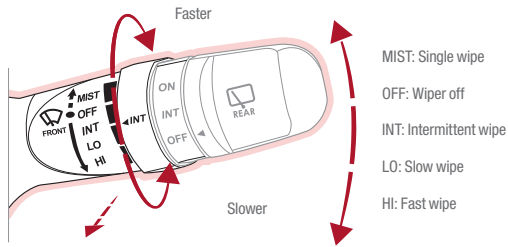

Rear Wiper & Washer

To operate:

- Rotate Rear Wiper switch to change Wiper modes
- Push to spray and wipe

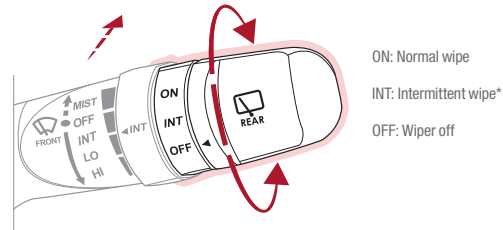

QR CODE

Soul Windshield Wipers & Washer Video

To view a video on your mobile device, snap this QR Code or visit the listed website.

Refer to page 2 for more information.



www.KuTechVideos.com/ps13/2015

FlexSteer™ Steering Wheel Mode

Select the desired steering mode by toggling through the steering modes.

- Press FlexSteer™ Steering Wheel Mode button **A** to display the steering mode on the LCD screen*
- Then press the button **A** again within 4 seconds to switch modes.

REMINDER: Your vehicle's steering wheel buttons may differ from those in the illustrations. See your Owner's Manual for more details.

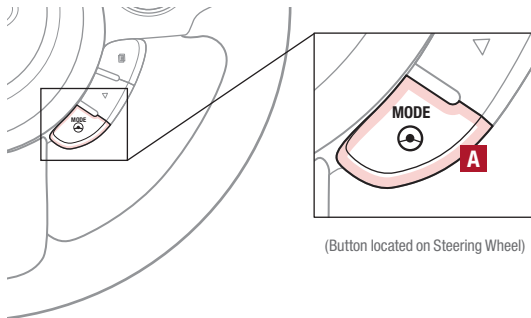
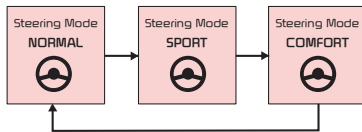

QR CODE

FlexSteer™ Steering Wheel Mode Video

To view a video on your mobile device, snap this QR Code or visit the listed website.

Refer to page 2 for more information.



www.KuTechVideos.com/ps13/2015

Audio Controls

Cruise Control*

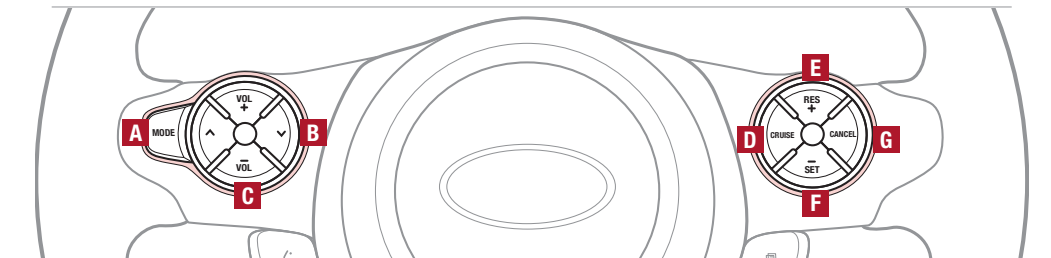

A Audio MODE button: Press to cycle through FM/AM/Sirius®/Media (USB, iPod®, Aux, BT Audio, My Music) modes

B Seek/Presets buttons

Radio Mode: Press to advance through Preset Stations. Press and hold to Auto Seek

Media Mode: Press to move track up/down. Press & hold to fast forward/rewind

C Volume buttons: Press VOL+ / VOL- to raise/lower volume

REMINDER: Your vehicle's steering wheel buttons may differ from those in the illustrations. See your Owner's Manual for more details.

Ⓢ QUICK TIPS

Pressing the Audio MODE button for more than 1 second will turn Audio Mode ON/OFF.

For further audio system operations, refer to pages 20-22.

D CRUISE Control On/Off button: Press to turn the Cruise Control on/off

E Resume Cruising Speed button: Press to resume or increase Cruising Speed

F SET Cruising Speed button: Press to set or decrease Cruising Speed

G Cruise Control CANCEL button: To cancel Cruise Control, do one of the following:

- Press the brake pedal
- Press the CANCEL button **G**

Ⓢ QUICK TIPS

- Cruise Control is designed to function above 25 mph
- The Cruise Control system will not activate until the brake pedal has been depressed at least once after ignition ON or engine starting

Driving while distracted is dangerous and should be avoided. Drivers should remain attentive to driving and always exercise caution when using the steering-wheel-mounted controls while driving

Bluetooth® Wireless Technology

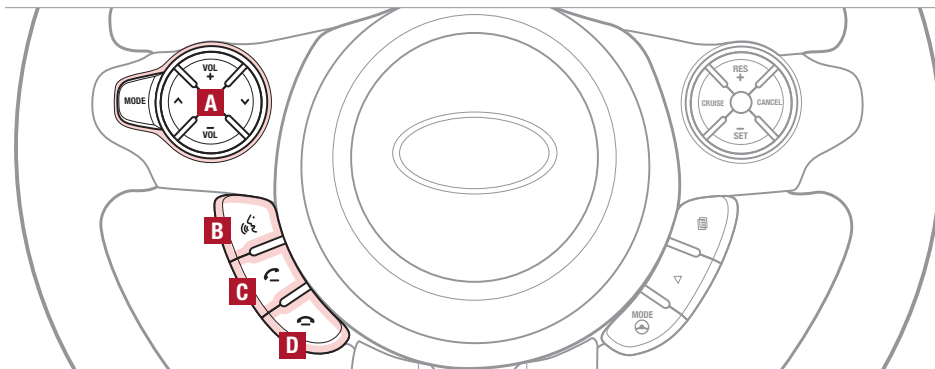

A Volume button: Press up/down to raise/lower speaker volume

B Talk button: Press to activate voice recognition / bring up menus / place calls with minimal voice command prompts from the system

Ⓢ QUICK TIPS

When using the voice command feature, wait for the system BEEP before speaking the command.

C Receive/Place Call button: Press to receive/place/transfer calls. Press to place a call using vocal command prompts from the system, or to answer an incoming call

D End Call button: Press to end a call or cancel a function

REMINDERS:

- Microphone is located in the overhead console
- Your vehicle's steering wheel buttons may differ from those in the illustrations. See your Owner's Manual for more details

Ⓢ QUICK TIPS

- Phone book transfer upload time varies by phone model and with number of phone book entries
- Because of differences in phone quality, service providers and Bluetooth® Wireless Technology chip programming, functionality may differ from one phone to another

Driving while distracted is dangerous and should be avoided. Drivers should remain attentive to driving and always exercise caution when using the steering-wheel-mounted controls while driving.

For more information, if equipped, refer to the Car Multimedia System User's Manual (Navigation System) or the UVO System User's Manual (UVO eServices System). For Bluetooth® Wireless Technology FAQs, go to www.kia.com, Owners section, or call Consumer Information for Bluetooth® Technology at (800) 333-4KIA.

Bluetooth® Wireless Technology

Pairing a Phone

For instructions on how to pair a phone, refer to the audio system's user's guide or your vehicle's Quick Start Guide.

🕒 QUICK TIPS

During the pairing process, be sure to accept the connection requests on the phone for phone book download and to allow acceptance of all future Bluetooth® connection requests.

How to Place a Call

When using the voice command feature, wait for the system BEEP before speaking the command.

There are two options for placing a call:

Standard Audio System*

- Option 1: Press the Receive/Place Call button **C** (system will prompt you through call process)
- Option 2: Press the Talk button **B** (system will BEEP to indicate it is ready for call placement). Then say the command "Call {name}" or "Dial {number}"

UVO eServices System*

- Option 1: Press the Receive/Place Call button **C** (displays the phone screen with number keypad)
- Option 2: Press the Talk button **B**. Then say the command "Call {name}" or "Dial {number}"

Navigation System*

- Option 1: Press the Receive/Place Call button **C** (displays the phone screen with number keypad)
- Option 2: Press the Talk button **B**. Then say the command "Call {name}" or "Dial {number}"

Voice Recognition and Phone Contact Tips

The Kia Voice Recognition System may have difficulty understanding some accents or uncommon names. When using Voice Recognition to place a call, speak in a moderate tone, with clear pronunciation.

Help your Bluetooth® Wireless Technology Voice Recognition performance by making a few simple changes to your phone contacts:

- Use full names vs. short or single syllable names ("John Smith" vs. "Dad", "Smith Residence" vs. "Home")
- Avoid using special characters or hyphens (@, &, #, /, -, *, +, etc.)
- Avoid using acronyms ("In Case Emergency" vs. "ICE")
- Spell words completely, no abbreviations ("Doctor Goodman" vs. "Dr. Goodman")

🕒 QUICK TIPS

Contacts Sync Tips

- If Contact Sync is set to ON, contacts store in your phone will download each time your phone is connected. There may be a delay before the system is available to place a call
- If Contact Sync is set to OFF, your phone contacts will download only at the initial pairing. This allows you to make calls without waiting for your phone contact list to download

📱 QR CODE

Voice Recognition Tips Video

To view a video on your mobile device, snap this QR Code or visit the listed website.

Refer to page 2 for more information.



www.KuTechVideos.com/ps13/2015

Standard Audio System*

– FM/AM/Sirius®/Media (USB, iPod®, Aux, BT Audio, My Music)

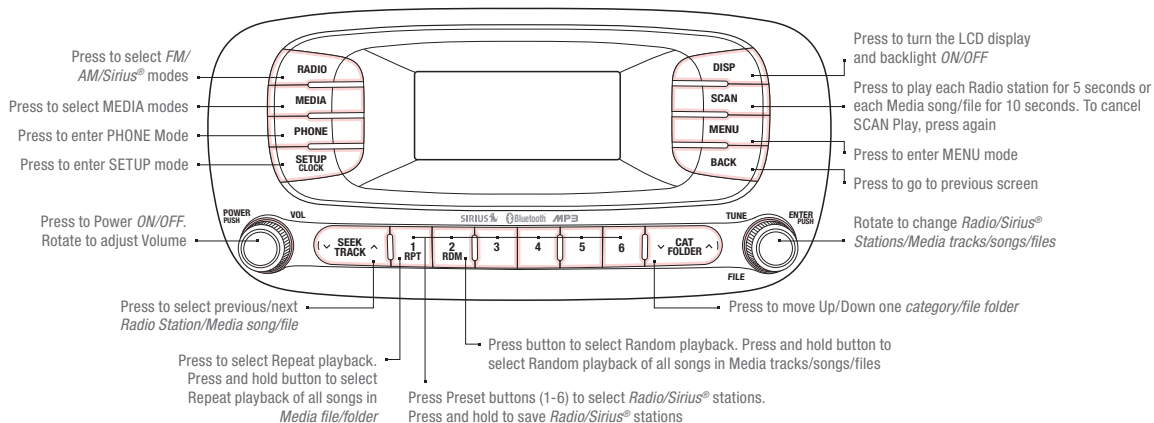

QR CODE

Standard Audio System Videos

To view a video on your mobile device, snap this QR Code or visit the listed website.

Refer to page 2 for more information.



KuTechVideos.com/audio/base_system

REMINDER: Your vehicle's audio system may differ from that in the illustration. See your Owner's Manual for more details.

Audio System Set-up Options

Press the SETUP button, then use the TUNE knob to cycle through the available settings for each equipped audio option. Press the TUNE knob to adjust the audio option selected. Audio options may include the following:

- Display settings
- Clock settings
- Sound settings
- System settings

To adjust the Sound settings (bass, middle, treble, fader, balance) – Select Sound settings in the SETUP menu. Then use the TUNE knob to cycle to the selection and then press the TUNE knob to select. Turn the TUNE knob left/right to adjust sound setting.

For further audio system operations, refer to pages 17-22.

UVO eServices System*

– FM/AM/Sirius®/Media (USB, iPod®, Jukebox, Aux, BT Audio, Pandora®)

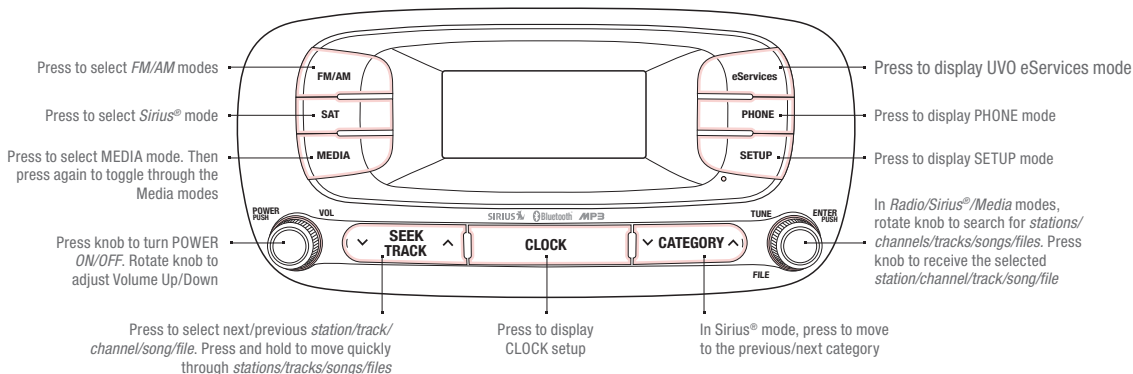

QR CODE

UVO eServices System Videos

To view a video on your mobile device, snap this QR Code or visit the listed website.

Refer to page 2 for more information.



KuTechVideos.com/audio/UVO_eServices

REMINDER: Your vehicle's audio system may differ from that in the illustration. See your Owner's Manual for more details.

To adjust the Sound settings (bass, middle, treble, fader, balance) - Select the on-screen SOUND button on the audio mode's display. Then press the on-screen CHANGE button of the selection (FADER/BALANCE, TONE). To adjust, press the on-screen arrows.

QUICK TIPS

- When using the voice command feature, wait for the system BEEP before speaking the command
- Only MP3 or WMA files may be played or copied to Jukebox. Commercial CDs or CDs with a CDDA audio format (compact disc digital audio) cannot be copied to Jukebox
- At any time, you can interrupt UVO eServices System Command Feedback by pressing the TALK button on the Steering Wheel
- Prolonged use of the UVO eServices System in ACC mode may drain the vehicle's battery

For further UVO eServices System operations, refer to the UVO System User's Manual. For further audio system operations, refer to pages 17-22.

Navigation System*

– FM/AM/Sirius®/Media (Aux, USB, iPod®, BT Audio, My Music)

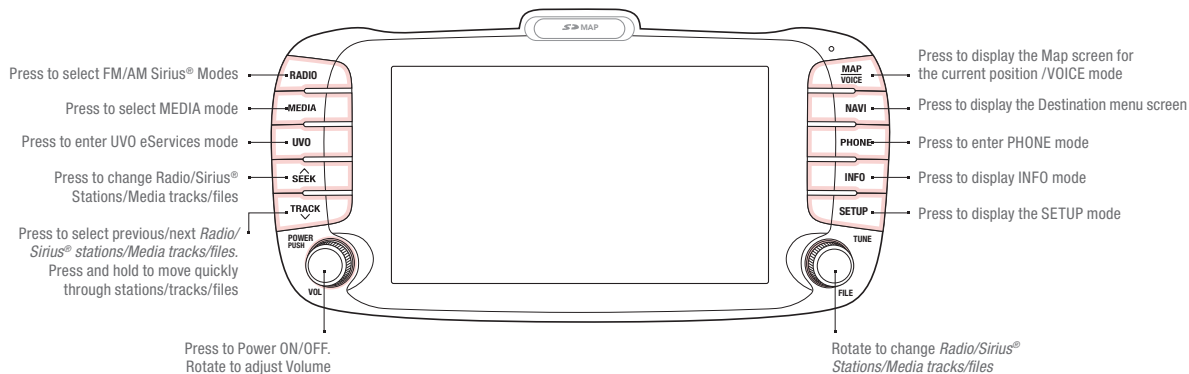

QR CODE

Navigation Audio System Videos

To view a video on your mobile device, snap this QR Code or visit the listed website.

Refer to page 2 for more information.



www.KuTechVideos.com/audio2/avn4

To adjust the Sound settings (bass, middle, treble, fader, balance) - Select the on-screen **SOUND** button on the audio mode's main screen. To adjust, press the on-screen arrows.

REMINDER: Your vehicle's audio system may differ from that in the illustration. See your Owner's Manual for more details.

QUICK TIPS

- When using the voice command feature, wait for the system BEEP before speaking the command
- Prolonged use of the Navigation System in ACC mode may drain the vehicle's battery. A warning screen may appear periodically to remind users that the Navigation System should be operated with the engine running to prevent battery discharge

For further Navigation System operation, refer to the Car Multimedia System User's Manual. For further audio system operations, refer to pages 17-22.

Advanced (Mood) Lighting Speaker*

The Advanced (Mood) Lighting Speaker that lights around the front speaker is controlled by turning the knob and pressing the buttons (located to the left of the steering wheel).

MOOD: Light intensity and color changes automatically at regular intervals.

MUSIC: Speaker light pulses and changes intensity according to the audio sound (audio must be on for this feature to work).

OFF: Speaker light turns OFF.

+/- : When light is ON, press illumination buttons to adjust light intensity.

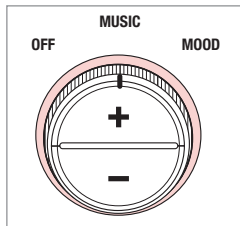

(Knob located on left side of Driver's Panel)

Ⓢ QUICK TIPS

- Door must be closed for this feature to work
- Prolonged use of lighting speaker in ACC mode may drain the vehicle's battery

Aux/USB/iPod® Port & Power Outlets

Ⓢ QUICK TIPS

The power outlets are inactive when ignition is in the OFF position.

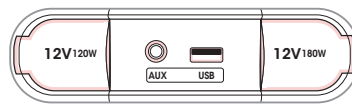

(Ports and power outlets located on lower part of Center Panel)

REMINDER: For the Tire Mobility Kit, only use the **12V/15A/180W** Power Outlet, located on the right side of the outlet/aux. port area.

QR CODE

USB Port Video

To view a video on your mobile device, snap this QR Code or visit the listed website.

Refer to page 2 for more information.



www.KuTechVideos.com/ps13/2015

Digital Clock

Standard Audio System Clock Setup*:

1. Press the SETUP button
2. Rotate knob to select Clock mode, then press to enter
3. Rotate knob to adjust Hour, then press to enter
4. Rotate knob to adjust Minute, then press to enter

UVO eServices System Clock Setup*:

Press the CLOCK button to display the Clock setting screen. Then use the on-screen buttons to navigate through setup.

Navigation System Clock Setup*:

Press the SETUP key, then the CLOCK button to display the Clock setting screen. Then use the on-screen buttons to navigate through setup.

Automatic Climate Control*

(Type B)

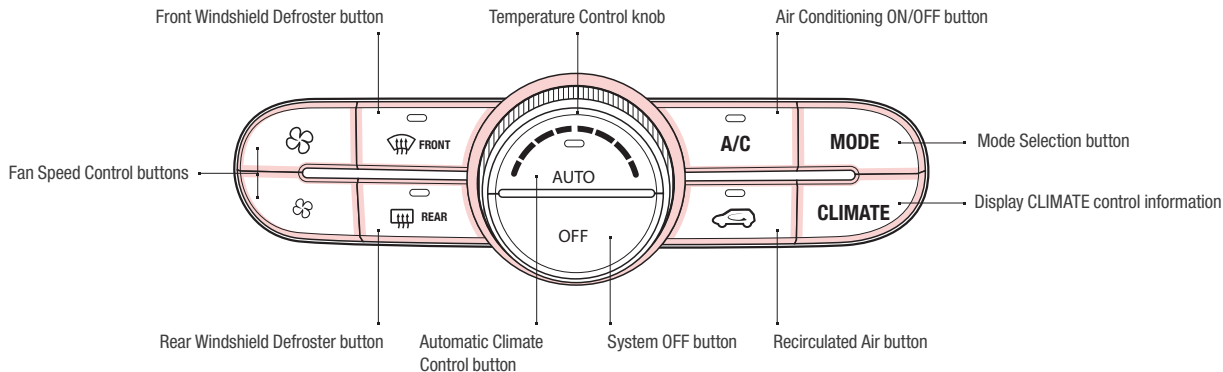

Air Flow Modes

To select Air Flow Modes, press the mode selection buttons:

-  Face-Level
-  Bi-Level
-  Floor-Level
-  Floor/Defrost-Level

Climate Control Auto Function:

1. Press **AUTO** to select Full Auto Operation
2. Press **MODE** buttons to control which vents air flows through

Defrost Outside Windshield:

1. Set **Fan Speed** to the highest position
2. Set **Temperature** to **Hot**
3. Press the **Defrost button** 

Defog Inside Windshield:

1. Set desired fan **Fan Speed**
2. Set desired **Temperature**
3. Press the **Defrost button** 

ⓘ QUICK TIPS

- Keep inside glass as clean as possible to reduce window fogging
- Defrost  mode activates A/C and opens Fresh Air Vent
- During Auto Operation the A/C indicator will NOT illuminate. The fan speed, air intake, air flow and air conditioning may automatically engage at any time to reach desired temperature and reduce humidity

REMINDERS:

- Warm air may flow in through vents if Recirculated Air button is not pressed ON (LED lit)
- Your Manual Climate Control system may differ from those in the illustrations. See your Owner's Manual for more details

Manual Climate Control*

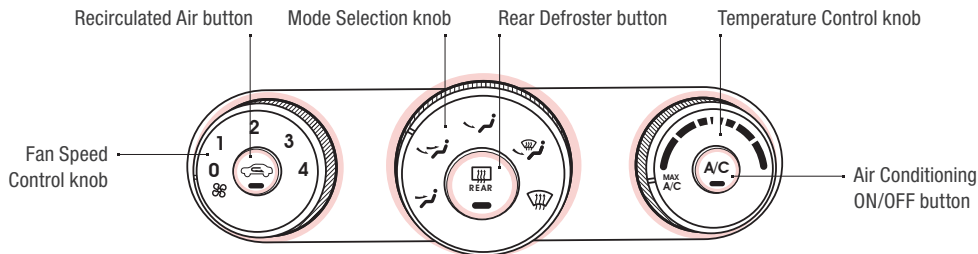

Air Flow Modes

To select Air Flow Modes, press the Mode selection buttons:

-  Face-Level
-  Bi-Level
-  Floor-Level
-  Floor/Defrost-Level

Defrost Outside Windshield:

1. Set **Fan Speed** to the highest position
2. Set **Temperature** to **Hot**
3. Rotate knob to the **Front Defroster** mode 

Defog Inside Windshield:

1. Set **Fan Speed** to desired position
2. Set desired **Temperature**
3. Rotate knob to the **Front Defroster** mode 

Ⓢ QUICK TIPS

- Defrost  Mode activates A/C and opens Fresh Air Vent
- MAX A/C Mode automatically engages Recirculated Air
- Keep inside glass as clean as possible to reduce window fogging

REMINDERS:

- Warm air may flow in through vents if Recirculated Air button is not pressed ON (LED lit)
- Your Manual Climate Control system may differ from those in the illustrations. See your Owner's Manual for more details

Automatic Gear Shift with Sportmatic® Shifting*

P: Park

R: Reverse

N: Neutral

D: Drive

[+]: Sport Mode Upshift

[-]: Sport Mode Downshift

Sport Mode: To enter Sport Mode, move shift lever from D to left gate

Sport Mode Shifting: Move shift lever up [+] to Upshift or down [-] to Downshift

Ⓢ QUICK TIPS

- Press brake pedal and depress release button to move gear shift from N to P, N to R or from P to any gear
- Sport Mode downshifts are made automatically when the vehicle slows down. When the vehicle stops, 1st gear is automatically selected

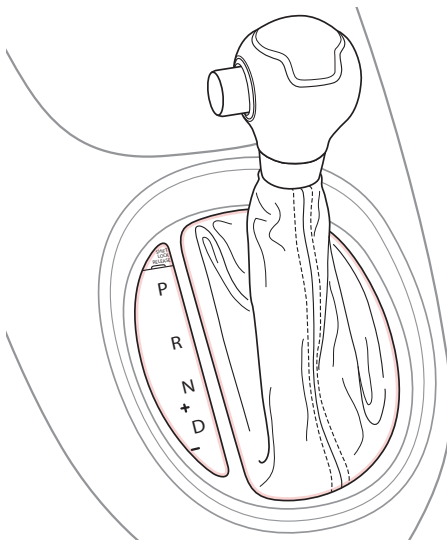

QR CODE

Sportmatic® Shifting Video

To view a video on your mobile device, snap this QR Code or visit the listed website.

Refer to page 2 for more information.



www.KuTechVideos.com/ps13/2015

Manual Gear Shift*

Starting the Engine

1. Pull up to apply Parking Brake **A**
2. Depress Clutch fully **B**
3. Shift into Neutral **C**
4. Turn Ignition to START

Shifting into Reverse

1. Depress Clutch fully **B**
2. Shift into Neutral **C**
3. Pull up on Shift Lever Ring **D**
4. Shift into Reverse **E**

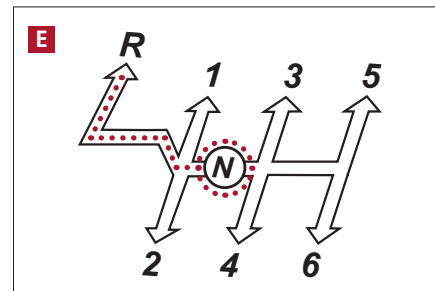
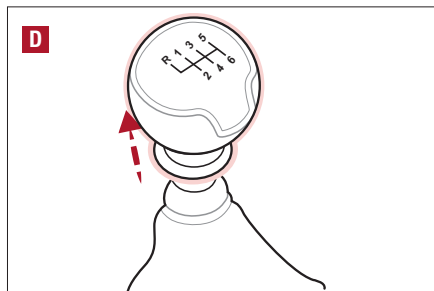
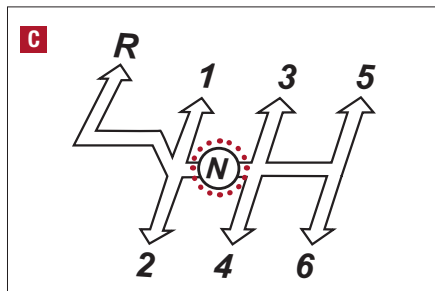
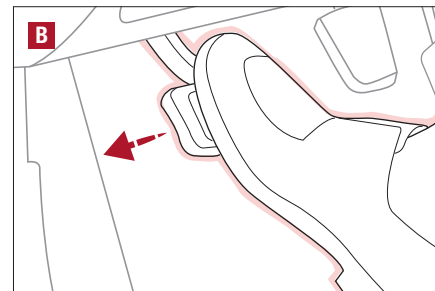
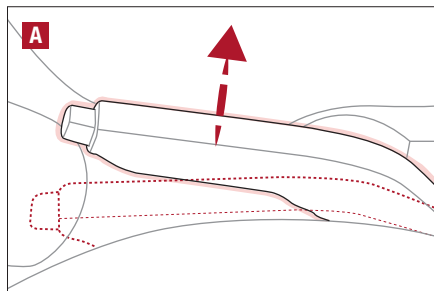

Ⓢ QUICK TIPS

When shifting into gears 1-6, the Shift Lever can be moved without pulling the Shift Lever Ring.

Seat Warmers*

Press button once for high setting (2 LEDs lit). Press button twice for low setting (1 LED lit). Press again to turn OFF.

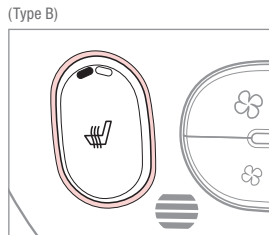

(Button located on Center Panel)

Seat Warmers / Ventilated Seats*

Seat Warmers – Press top of button once for high setting (3 LEDs lit). Press button twice for medium setting (2 LEDs lit). Press a third time for low setting (1 LED lit) and again to turn OFF.

Ventilated Seats – Press bottom of button once for high setting (3 LEDs lit). Press twice for medium setting (2 LEDs lit). Press a third time for low setting (1 LED lit) and again to turn OFF.

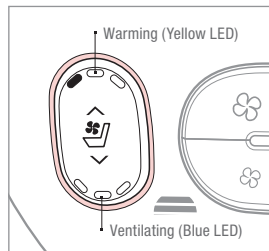

(Button located on Center Panel)

Ⓢ QUICK TIPS

- System turns OFF when ignition is cycled. To turn system ON, press the seat warmer switch
- With the seat warmer switch in the ON position, the heating system in the seat turns off or on automatically depending on the seat temperature

6-Way Manual Adjustable Driver's Seat*

Pull lever **A** to slide Seat forward/backward.

Pull/press lever **B** to adjust Seat Height.

Pull lever **C** to adjust Seatback Recline.

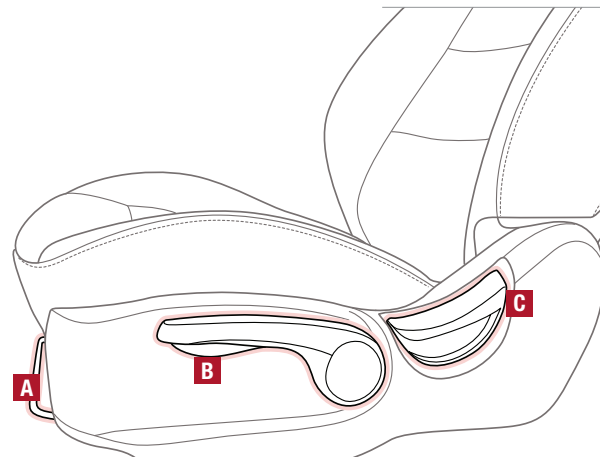

Power Adjustable Driver's Seat*

Move/Press controls to adjust Seat forward/backward, Seat Cushion height, Seatback recline or Lumbar forward/backward.

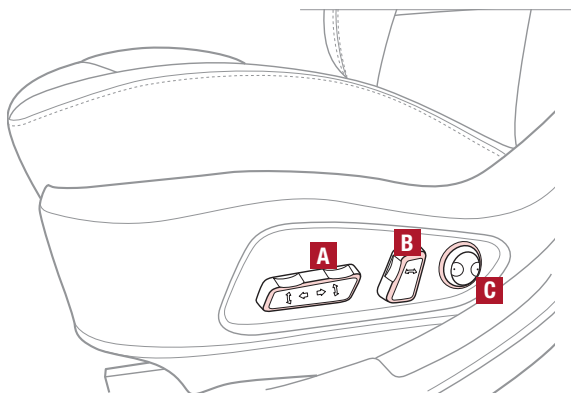
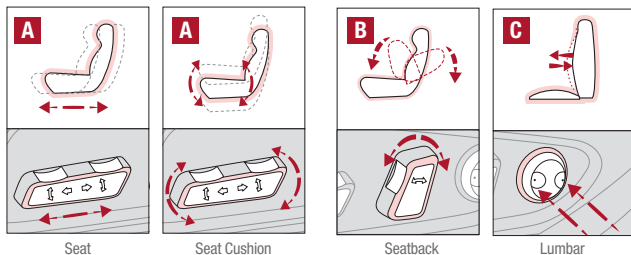

Front Seat Headrest Adjustment

To adjust headrest forward*: Pull headrest forward to one of several positions.

To adjust headrest back*: Pull headrest completely forward, then release.

To raise headrest: Pull headrest up.

To lower headrest: Press lock, then press the headrest down.

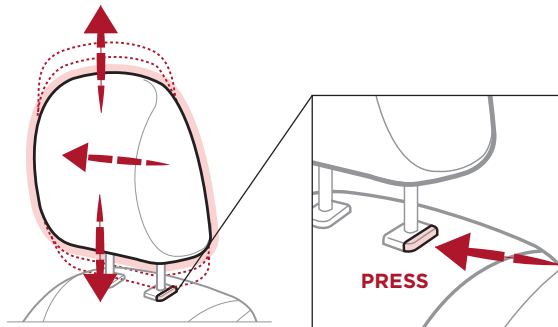

Ⓢ QUICK TIPS

For easy adjustments, hold a headrest post with one hand while using the other hand to pull the headrest from underneath.

Folding Rear Seatback

To Fold:

1. Adjust the Front Seatback in the upright position and/or slide the Front Seat forward
2. Insert the rear seat belt strap into the clip located on the side panel next to the Seatback
3. Lower the Rear Headrests to the lowest position
4. Pull on the Rear Seatback folding lever **A**, then fold the seat towards the front

REMINDER: Always make sure the seat back is locked in place when unfolded.

To Unfold:

1. Lift and pull the Seatback backward by pulling on the folding lever **A**. Pull the Seatback firmly until it clicks and is locked into place
2. Return the rear seat belt to the proper position

© QUICK TIPS

It may be necessary to adjust the front seatbacks to fully lower rear seats.

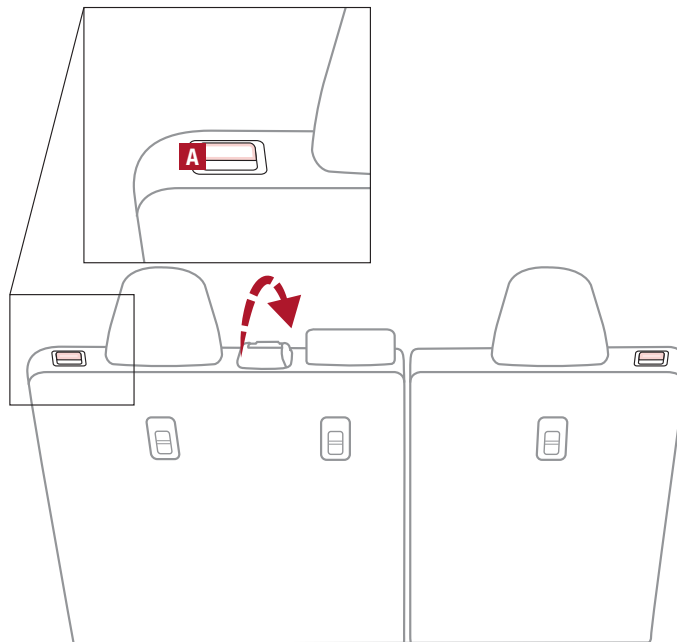

Smart Key*

Smart Key Fob:

- A** Press to lock All Doors
 - B** Press to unlock Driver's Door. Press twice in 4 seconds to unlock All Doors
 - C** Press and hold for more than 1 second to unlock Rear Hatch and manually open
- REMINDER:** The Rear Hatch unlocks when the Smart Key fob is within close proximity of the vehicle.
- D** Press and hold more than 1 second for Panic Alarm. To turn off Alarm, press any button
 - E** Press to release Mechanical Key (Button located on back of Smart Key)

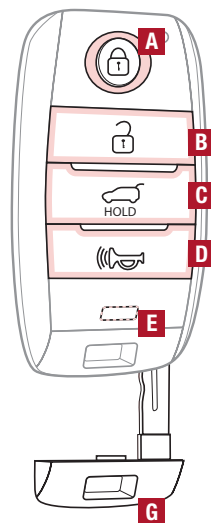

Driver's Door Lock/Unlock button **F**:

- Press button once to unlock driver's door
- Press again within 4 seconds to unlock all doors
- Press again to lock all doors

Mechanical Key **G**:

- Use to unlock driver's door
- Use to turn Child Safety Locks

For more information on the Mechanical Key, please refer to your Owner's Manual.

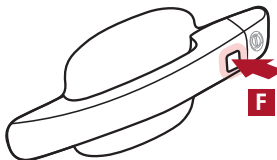

QR CODE

Engine Start/Stop Button & Smart Key Video

To view a video on your mobile device, snap this QR Code or visit the listed website. Refer to page 2 for more information.



www.KuTechVideos.com/ps13/2015

QUICK TIPS

The Smart Key's signal can be blocked by the normal operation of a cell or smart phone. To help prevent this, store each device separately.

REMINDER: Remote button configuration may vary depending on vehicle options.

Remote Keyless Entry*

- A** Press the release button to unfold the key
- B** Press to Lock All Doors
- C** Press to unlock Driver's Door. Press twice in 4 seconds to unlock All Doors and Rear Hatch
- D** Press and hold for more than 1 second to unlock Rear Hatch and manually open
- E** Press and hold more than 1 second for Panic Alarm. To turn OFF Alarm, press any button

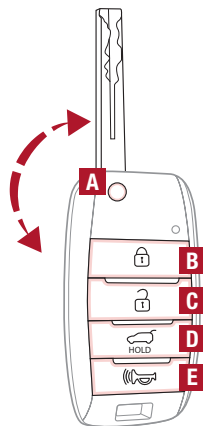

REMINDERS:

- The Rear Hatch does not automatically open when the **D** button is pressed
- The Rear Hatch unlocks when the Smart Key fob is within close proximity of the vehicle
- Remote button configuration may vary depending on vehicle options

Double-Turn Lock / Unlock All

- Turn counterclockwise once to unlock Driver's Door
- Turn counterclockwise again within 4 seconds to unlock All Doors
- Turn clockwise once to Lock All Doors

Fuel Cap Open Warning Indicator

Tighten for ONE CLICK to prevent Fuel Cap Open Warning Indicator  from illuminating.

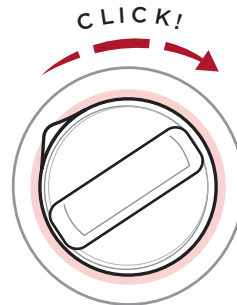

REMINDER: The Fuel Door Release Lever is located on the lower part of the driver's door sill.

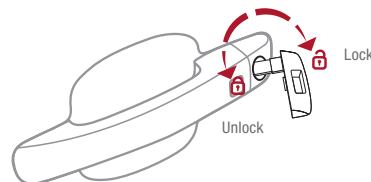

QR CODE

One-Click Fuel Cap Video

To view a video on your mobile device, snap this QR Code or visit the listed website.

Refer to page 2 for more information.



www.KuTechVideos.com/ps13/2015

Map/Room Lamps

Push the lens **A** to turn the Map Lamp ON/OFF. This light produces a spot beam for convenient use as a map lamp or personal lamp for the driver or front passenger.

When the DOOR button **B** is pressed, the Map Lamp turns ON when any door is opened.

When the ROOM button **C** is pressed, the Map and Room Lamps turn ON.

Room Lamp

When the Room Lamp button **D** is pressed, the lamp turns ON.

Automatic turn off function*

The interior lights automatically turn off approximately 30 seconds after the Engine System Start/Stop button* is OFF.

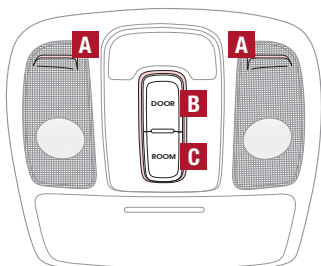

(Type A)

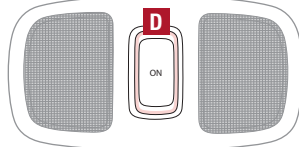

(Type A)

Ⓢ QUICK TIPS

- When doors are unlocked by the Smart Key*, the lamp turns ON for approximately 30 seconds
- If your vehicle is equipped with the theft alarm system, the interior lights automatically turn off approximately 3 seconds after the system is in armed stage
- Using interior lights for an extended period of time may cause battery discharge

Sunvisor

Use the Sunvisor to shield direct light through the front or side windows. Slide the Sunvisor out and adjust as needed.

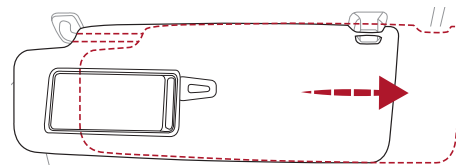

REMINDERS:

- Sunvisor may not shield all direct light
- Do not operate the vehicle if Sunvisor is impairing your visibility
- The Sunvisor may impair visibility if not adjusted properly

Panoramic Sunroof Operation*

The sunroof operation is controlled through a multidirectional switch/lever and the sunshade is controlled through the OPEN/CLOSE buttons. The ignition needs to be in the ON position to operate the Sunroof and Sunshade.

Slide the Sunroof:

- **Open:** Slide the lever **A** backward
- **Close:** Slide the lever **A** forward

REMINDER: If closed, the Sunshade will also open when lever is pressed backward.

Tilt the Sunroof:

- **Raise:** Push lever **A** upward
- **Lower:** Pull lever **A** downward
- **Auto Close:** Press the CLOSE toggle button **B**

REMINDER: If closed, the Sunshade will also open when lever is pressed backward.

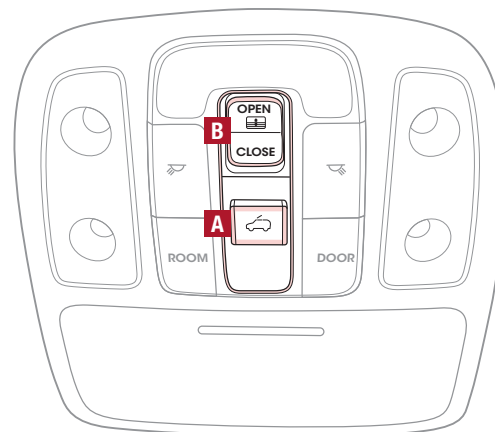

Slide the Sunshade:

- **Open:** Press the OPEN toggle button **B**
- **Close:** Press the CLOSE toggle button **B**

REMINDEES:

- If open, the Sunroof will also close when the toggle button is pressed
- Sunshade needs to remain OPEN while Sunroof is open and vehicle is moving

Ⓢ QUICK TIPS

To stop the Sunroof/Sunshade at any position, push or pull the sunroof control lever in any direction.

Sunroof Open Warning*

If the Sunroof is not fully closed, the warning will chime and display on the LCD screen* when:

- The ignition is turned off (Smart Key*)
- The driver's door is opened
- The ignition key is removed

Rear-Camera Display*

The Rear-Camera Display system is not a safety device. It is a supplemental system that displays the view behind the vehicle through the Navigation System* or UVO eServices System* screen while the vehicle is in Reverse.

The Rear-Camera Display activates when the:

1. ENGINE START/STOP button* is in the ON position (green light)
2. Gear Shift Lever is in the R (Reverse) position



(Rear-Camera Display)

REMINDER: While camera is active, only the volume controls on the Audio System can be operated.

The Rear-Camera Display is not a substitute for proper and safe backing-up procedures. The Rear-Camera Display may not display every object behind the vehicle. Always drive safely and use caution when backing up.

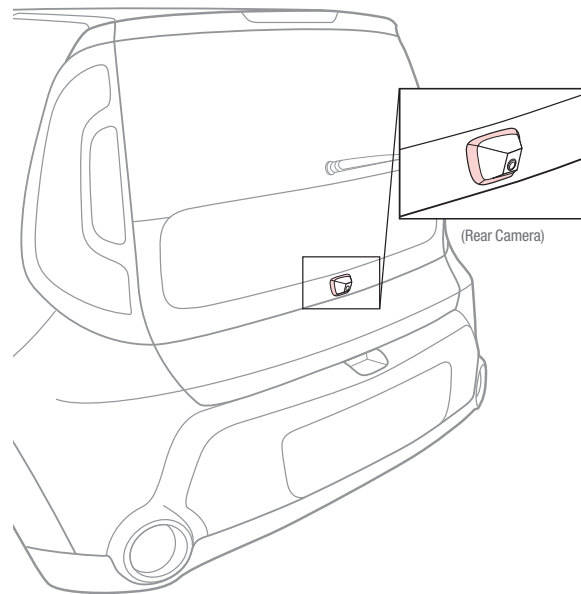

(Rear Camera)

Hood Release Lever and Latch

Opening the Hood:

1. Located on the bottom left of the driver's panel, pull the Hood Release Lever **A** to unlatch the Hood
2. In the front of the vehicle, lift the Hood slightly, push the secondary Latch **B** up inside of the Hood's center and lift the Hood

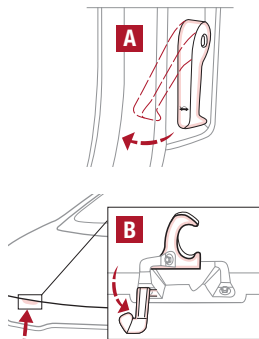

Closing the Hood:

Lower the Hood by pressing the front center of the Hood. Then, press down to securely lock in place.

REMINDER: While lowering and closing, keep hands away from under the Hood.

Fuel Door Release Lever

Lift the **C** lever upwards to release the fuel door.

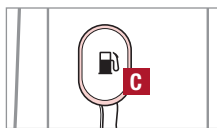

(Lever located on the driver's floor near door sill)

Tire Mobility Kit

The Tire Mobility Kit may temporarily seal certain types of tire damage.

For operational information, please refer to section 6 of your Owner's Manual.

A Sealant Bottle

B Compressor

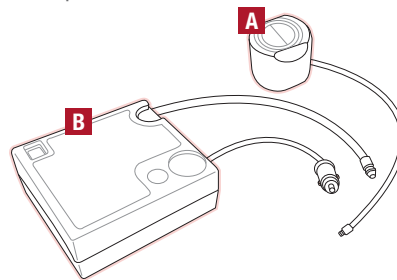

ⓘ QUICK TIPS

- The Tire Mobility Kit is a temporary fix and is to be used for one tire only; the tire should be inspected as soon as possible
- The kit should only be used for sealing/inflating passenger car tires; do not use for inflating any other type of tires
- Some damaged tires cannot be sealed completely; do not use the kit if a tire is damaged beyond repair

📺 QR CODE

Tire Mobility Kit Video

To view a video on your mobile device, snap this QR Code or visit the listed website.

Refer to page 2 for more information.



www.KuTechVideos.com/ps13/2015

REMINDERS:

- The Tire Mobility Kit requires the use of the 12V/15A/180W Power Outlet, which is located on the right side of the outlet/aux port area
- After tire is properly sealed, drive cautiously at no more than a total distance speed of 50 mph for no longer than a maximum distance of up to 120 miles

Rear Hatch Release Button

Button is located underneath the Rear Hatch lid. With Rear Hatch unlocked, press the Rear Hatch Release button **A** and pull the Rear Hatch lid up by the handle to open.

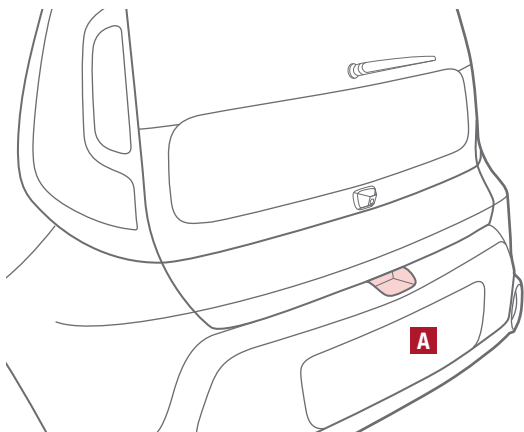

Child Safety Locks

Located on the rear edge of the rear passenger doors, adjust switch **A** to the LOCK position to disable the inner door handles from opening the rear doors.

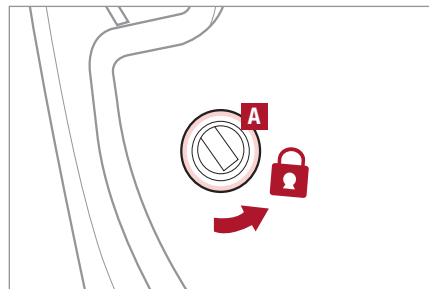

REMINDER: Child Safety Lock is located on rear passenger's door jamb.

Ⓢ QUICK TIPS

- The Rear Hatch must be unlocked before it can be opened by the Rear Hatch Release Button
- The Rear Hatch unlocks automatically and then can be opened manually when the Smart Key* is within close proximity to the vehicle

Seat Belts

To properly fasten your seat belts:

1. Insert the tongue belt plate **A** into the buckle **B** until it clicks
2. Position the lap portion of the belt across your lap as **LOW ON THE HIPS** as possible **C**. Adjust the belt to a **SNUG FIT** by pulling up on the shoulder portion **D**

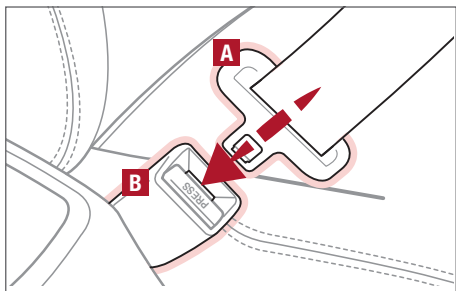

Seat Belt Retractor Locks

- Retractor locks allow lap/shoulder seat belts to remain unlocked during normal vehicle operation for freedom of movement and increased comfort
- During a **STRONG STOP, SUDDEN TURN OR CERTAIN COLLISIONS**, seat belt retractors will automatically lock the belts to reduce the risk of injury

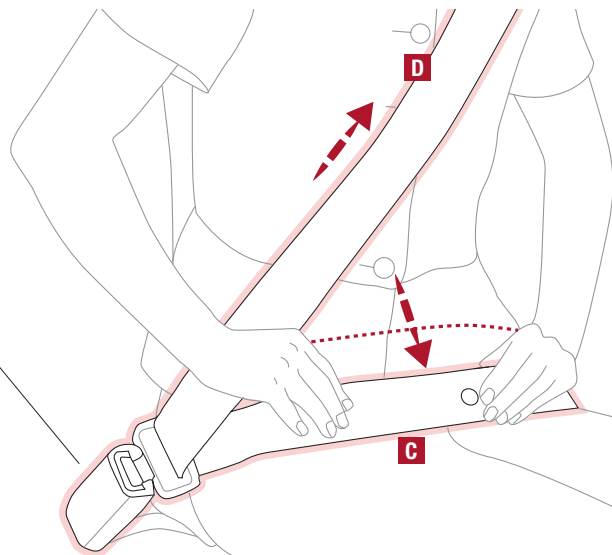

Ⓢ QUICK TIPS

The Seat Belt warning chime operates for driver's seat only.

For more detailed information regarding your vehicle's seat belts, please refer to your Owner's Manual and the separate brochure titled "Understanding Your Safety Belt & Supplemental Restraint System."

Occupant Detection System (ODS) / PASSENGER AIRBAG OFF Indicator

ODS detects the presence and position of the front passenger and adjusts or turns off airbag deployment accordingly.

Depending on the situation and type of accident, the system may:

- Deploy airbag (Adult)
- Not deploy the airbag (Unoccupied)

If the system determines that the airbag should not be deployed, the “PASSENGER AIRBAG OFF” light will illuminate.



LEGAL DISCLAIMERS

Warning: Driving while distracted can result in a loss of vehicle control that may lead to an accident, severe personal injury and death. The driver's primary responsibility is in the safe and legal operation of a vehicle, and use of any handheld devices, other equipment or vehicle systems which take the driver's eyes, attention and focus away from the safe operation of a vehicle or that are not permissible by law should never be used during operation of the vehicle.

Safety Features: No system, no matter how advanced, can compensate for all driver error and/or driving conditions. Always drive responsibly.

Electronic Stability Control and Hill-Start Assist Control: No system, no matter how advanced, can compensate for all driver error and/or driving conditions. Always drive responsibly.

Back-Up Warning System (Rear Parking Assist System) / Rear-Camera Display: The Back-Up Warning System (Rear Parking Assist System) and Rear-Camera Display are not substitutes for proper and safe backing-up procedures. The Back-Up Warning System (Rear Parking Assist System) / Rear-Camera Display may not detect every object alongside or behind the vehicle. Always drive safely and use caution when backing up.

Tilt/Telescoping Steering Wheel: Never attempt to adjust steering wheel position when vehicle is in motion.

Front Seat Headrest Adjustment: Never attempt to adjust headrests when vehicle is in motion.

Seat Belts / Airbags: For maximum protection, always wear your seatbelt.

Navigation: GPS maps and directions are for information purposes only, and Kia does not make any warranties about the accuracy of that information. Kia is not responsible for loss or delay resulting from the use of the navigation system. Caution: Do not enter information into the navigation system while the vehicle is moving. Failure to pay attention to travel conditions and vehicle operation while the vehicle is in motion could result in loss of vehicle control. Operate the system only when it is safe and legal to do so.

TPMS: Even with the Tire-Pressure Monitoring System (TPMS), always check your tire pressure on a regular basis.

Bluetooth® Wireless Technology: A compatible Bluetooth® wireless technology-enabled cell phone is required to use Bluetooth® wireless technology. The Bluetooth® word mark and logos are registered trademarks owned by Bluetooth SIG, Inc. and any use of such marks by Kia is under license. Other trademarks and trade names are those of their respective owners. A Bluetooth® enabled cell phone is required to use Bluetooth® wireless technology.

SiriusXM®: SiriusXM Satellite Radio, SiriusXM Traffic and SiriusXM Travel Link each require a subscription sold separately, or as a package, by SiriusXM Radio Inc. **If you decide to continue your service at the end of your trial subscription, the plan you choose will automatically renew and bill at then-current rates until you call 1-866-635-2349 to cancel. See SiriusXM Customer Agreement for complete terms at www.siriusxm.com.** Other fees and taxes will apply. All fees and programming are subject to change. Not all vehicles or devices are capable of receiving all services offered by SiriusXM. Data displays and individual product availability vary by vehicle hardware. Current information and features may not be available in all locations, or on all receivers. Weather Forecast, Current Conditions may not be available in all locations. Images above are for representative purposes only and are not real products. For actual features and images of real products, consult the vehicle manufacturer. SiriusXM is not responsible for any errors or inaccuracies in the data services or their use in the vehicle. Travel Link Stocks displays current price and daily delta of around 7,000 actively reported securities traded on the NYSE®, NASDAQ® and AMEX®. The service is delayed approximately 20 minutes. SiriusXM satellite service is available only to those at least 18 years of age in the 48 contiguous USA, DC, and Puerto Rico (with coverage limitations). SiriusXM Internet Radio service is available throughout our satellite service area and in AK and HI. © 2014 SiriusXM Radio Inc. Sirius, XM and all related marks and logos are trademarks of SiriusXM Radio Inc.

UVO eServices app: Apple iPhone® and select Android™ devices only are UVO eServices compatible. iPhone® is a registered trademark of Apple Inc. Android™ is a registered trademark of Google Inc. No subscription fee for UVO eServices. No charge for the UVO eServices app. App uses your smartphone cellular data service. Normal data rates will apply.

Sportmatic® is a registered trademark of Kia Motors America.

iPod® is a registered trademark of Apple Inc. iPod® mobile digital device sold separately, and connectivity requires the Kia accessory cable.

HomeLink® is a registered trademark of Gentex Corporation.

Pandora is a registered trademark of Pandora Media, Inc.



NORMAL MAINTENANCE SCHEDULE

When your vehicle requires service, remember that your dealer knows your vehicle best. Your dealer has factory-trained technicians, recommended special tools, genuine Kia replacement parts, and is dedicated to your complete satisfaction. For expert advice and quality service, see your authorized Kia dealer.

INTERVAL MAINTENANCE CHART							
7,500 miles	A						
15,000 miles	A	B					
22,500 miles	A						
30,000 miles	A	B	C				
37,500 miles	A			D			
45,000 miles	A	B					
52,500 miles	A						
60,000 miles	A	B	C		E		
67,500 miles	A						
75,000 miles	A	B		D	E		
82,500 miles	A						
90,000 miles	A	B	C		E		
97,500 miles	A						
105,000 miles	A	B		D	E	F	
112,500 miles	A						
120,000 miles	A	B	C		E		G

A Inspect* — Air cleaner filter, brake lines, hoses and connections, disc brakes and pads**, drum brakes and linings**, brake pedal and operation, brake fluid, clutch fluid**, exhaust pipe and muffler, chassis/body nuts and bolts, steering operation and linkage, suspension mounting bolts, drive shaft and boots, air conditioning compressor, air conditioning refrigerant/performance**, cooling system¹, battery condition, front suspension ball joints, fuel tank, fuel cap, fuel lines, fuel hoses, lubricate all locks and hinges, parking brakes

Replace — Engine oil, engine oil filter

Perform — Rotate tires; add fuel additive²

B Replace — Climate control air filter**

C Inspect* — Fuel tank air filter (CCV filter)², fuel filter², vapor hose and fuel filler cap

Replace — Air cleaner filter

D Inspect* — Manual transmission fluid**

E Inspect* — Drive belt³ — then every 15,000 miles afterwards. Inspect valve clearance⁴ (Engine 1.6) (Every 90,000 miles or 72 months)

F Replace — Spark plugs**

G Replace — Engine coolant^{5****}

* and, if necessary, adjust, clean, replace or correct

** If equipped

*** Check and adjust level and check for leaks. Inspect regularly

Check tire pressure once a month or more.

Transfer case oil and rear differential oil should be changed anytime they have been submerged in water.

¹ When adding coolant, use only deionized water or soft water for your vehicle and never mix hard water in the coolant filled at the factory. An improper coolant mixture can result in serious malfunction or engine damage.

² If TOP TIER detergent gasoline is not available, one bottle of additive is recommended. Additives are available from your authorized Kia dealer along with information on how to use them. Do not mix other additives.

³ Inspect "Water Pump" when replacing the drive belt or timing belt.

Fuel filter & fuel tank air filter are considered to be maintenance free but periodic inspection is recommended for this maintenance schedule depends on fuel quality. If there are some important safety matters like fuel flow restriction, surging, loss of power, hard starting problem etc, replace the fuel filter immediately regardless of maintenance schedule and consult an authorized Kia dealer for details. The drive belt should be replaced when cracks occur or tension is reduced excessively.

⁴ Inspect for excessive tappet noise and/or engine vibration and adjust if necessary.

⁵ When replacing coolant, use only a qualified coolant additive for your vehicle and never mix hard water in the coolant filled at the factory. An improper coolant mixture can result in serious malfunction or engine damage.

See your Owner's Manual for more details and complete maintenance information, including severe maintenance schedule.

Warranty may be voided if maintenance schedule is not followed.

Call 1-800-333-4KIA (4542) for Roadside Assistance.



SOUL CUSTOMER DELIVERY CHECKLIST

Owner's Name: _____ VIN: _____ Mileage: _____

Dealership Name: _____ Sales Consultant: _____ Date: _____

BEFORE DELIVERY

- Test and confirm "Good Battery" using the Kia GR8-1299 battery tester and affix Results Label
- Verify all tire pressures are to spec (see driver's door label) LF _____ LR _____ RF _____ RR _____
- Verify proper operation of Remote Keyless Entry and Smart Key lock/unlock
- Ensure floor mats are snapped into place (if applicable)
- Verify vehicle is clean (interior and exterior), in good condition and free of chips and scratches
- Ensure all key documents are in the vehicle (Owner's Manual, Warranty and Consumer Information booklet, Tire Warranty booklet and Features & Functions Guide and any Audio System User's Manual.)

KEY FEATURE WALK-THROUGH

- Air Conditioning / Climate Control – pages 24-25
Demonstrate Air Flow Modes, Defog and Defrosting Windshield.

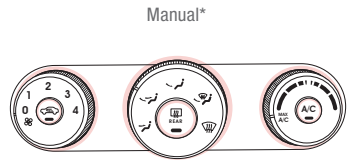
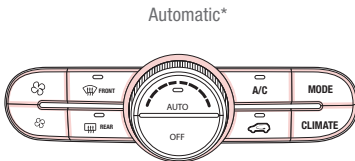

- Manual Gear Shift* – page 27
Demonstrate lifting ring for reverse gear

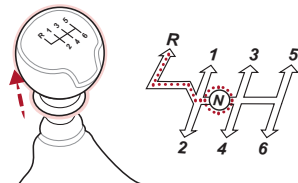

- Windshield/Rear Wipers & Washers* – page 15

Rotate level to adjust Intermittent Wipe Speed.

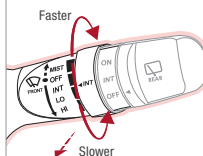

Pull to spray and wipe.

- MIST: Single wipe
- OFF: Wiper off
- INT: Intermittent wipe
- LO: Slow wipe
- HI: Fast wipe

Move lever Up/Down to change Wiper modes.

Push to spray and wipe.

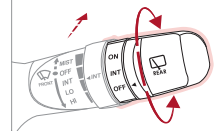

- ON: Normal wipe
- INT: Intermittent wipe
- OFF: Wiper Off



SOUL CUSTOMER DELIVERY CHECKLIST

KEY FEATURE WALKTHROUGH

Demonstrate the following with the customer:

- Standard Audio System* – page 20

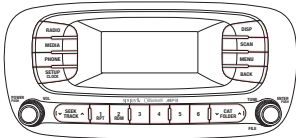

- UVO eServices System* – page 21
For further UVO eServices System information, refer to the UVO System User's Manual.

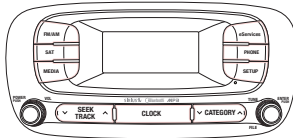

- Navigation System* – page 22
For further Navigation System operation, refer to the Car Multimedia System User's Manual.



- Aux/USB/iPod® Port – page 23



- Cruise Control* – page 17
Demonstrate operation

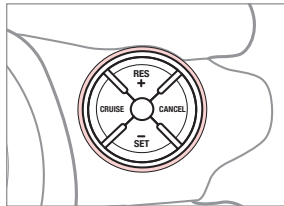

- Bluetooth® Wireless Technology – page 18
Demonstrate operation

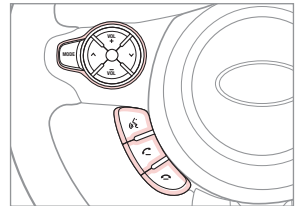

- Active ECO System* – page 8
- Digital Clock – page 23
- Engine Start/Stop Button* – page 12
- Folding Rear Seatback – page 30
- ISG (Idle, Stop, Go) System* – page 10
- Panoramic Sunroof Operation* – page 34
- Passenger Airbag Off Indicator – page 39

- Rear-Camera Display* – page 35
- Seat Warmers / Ventilated Seats* – page 28
- Smart Key* – page 31
- Tire Mobility Kit – page 36
- Tire Pressure Monitoring System (TPMS) – page 5

*IF EQUIPPED

DURING DELIVERY

- Explain first service process and schedule first service appointment
- Tour Parts & Service departments, introduce staff & explain value of Kia Parts and Service
- Review recommended maintenance schedule and maintenance requirements to validate warranty
- Review business hours & Customer 360° Care
- Review the Kia 10-year/100,000-mile warranty program
- Ensure 100% satisfaction with sales and delivery process and no problems with the vehicle
- Confirm time and best contact number for initial dealer follow-up

Sales Consultant: _____ Date: _____

Sales Manager: _____ Date: _____

Customer: _____ Date: _____