

2012

**OWNER'S MANUAL
SUPPLEMENT**

CHARGER
POLICE

INSTALLATION OF RADIO TRANSMITTING EQUIPMENT

Special design considerations are incorporated into this vehicle's electronic system to provide immunity to radio frequency signals. Mobile two-way radios and telephone equipment must be installed properly by trained personnel. The following must be observed during installation.

The positive power connection should be made directly to the battery and fused as close to the battery as possible. The negative power connection should be made to body sheet metal adjacent to the negative battery connection. This connection should not be fused.

Antennas for two-way radios should be mounted on the roof or the rear area of the vehicle. Care should be used in mounting antennas with magnet bases. Magnets may affect the accuracy or operation of the compass on vehicles so equipped.

The antenna cable should be as short as practical and routed away from the vehicle wiring when possible. Use only fully shielded coaxial cable.

Carefully match the antenna and cable to the radio to ensure a low Standing Wave Ratio (SWR).

Mobile radio equipment with output power greater than normal may require special precautions.

All installations should be checked for possible interference between the communications equipment and the vehicle's electronic systems.

TABLE OF CONTENTS

SECTION		PAGE
1	INTRODUCTION	3
2	THINGS TO KNOW BEFORE STARTING YOUR VEHICLE	5
3	UNDERSTANDING THE FEATURES OF YOUR VEHICLE	19
4	UNDERSTANDING YOUR INSTRUMENT PANEL	29
5	STARTING AND OPERATING	33
6	WHAT TO DO IN EMERGENCIES	39
7	MAINTAINING YOUR VEHICLE	49
8	MAINTENANCE SCHEDULES	53
9	INDEX	57

1

2

3

4

5

6

7

8

9

INTRODUCTION

CONTENTS

■ Introduction	4
----------------------	---

INTRODUCTION

This booklet is a supplement to the Owner's Manual prepared with the assistance of service and engineering specialists, and is intended to aid the operators of police or fleet vehicles (used in severe duty, high-mileage operations) in understanding the operation and required maintenance procedures for such vehicles. It covers maintenance procedures for vehicles equipped with heavy-duty packages. However, other vehicles operated under the conditions listed below are also considered "severe service" vehicles, and should be serviced and maintained as prescribed in this booklet. This supplement applies to rear-wheel drive passenger cars only. You are urged to read this publication and the Owner's Manual carefully.

Refer to the Police Upfitter's Guide provided with your vehicle, prior to the addition of any aftermarket equipment.

Following the instructions and recommendations provided herein, will help assure safe and reliable operation of your vehicle. After you have read the booklet, it should be stored in the vehicle for convenient reference and remain with the vehicle when sold.

THINGS TO KNOW BEFORE STARTING YOUR VEHICLE

CONTENTS

■ Modified Rear Door – Locks, Levers, And Window Switches — If Equipped	6	□ Air Bag Deployment Zones	8
■ Occupant Restraints	7		

6 THINGS TO KNOW BEFORE STARTING YOUR VEHICLE

MODIFIED REAR DOOR – LOCKS, LEVERS, AND WINDOW SWITCHES — IF EQUIPPED

The emergency rear door lock knob is located on the front portion of each rear door panel, visible when the front door is opened. Pull the knob out to unlock the door. The rear doors can be locked from the outside of the vehicle by pushing the knob in.



023310788

Emergency Door Lock Knob

Both rear passenger doors are inoperable from the rear seat position, inside of the vehicle. There are three ways to operate the rear door locks:

- The emergency rear door lock knob on the front portion of each rear door panel
- Either front door lock switch
- The remote keyless entry transmitter

The rear windows are inoperable from the rear door switches. Rear windows are only operable by the driver door master switch.

OCCUPANT RESTRAINTS

Driver/passenger air bags affect the way police equipment can be safely mounted in police vehicles.

Any surface that could come into contact with an air bag, once it has been deployed, must not damage the air bag or alter its deployment path.

The addition of the supplemental equipment (such as radios, weapons, mounting brackets, cage, etc.), must be installed such that it will not interfere or come in contact with a deploying air bag. Air bag deployment zones are described below. Sharp edges, corners or protrusions on supplemental equipment, could damage the nylon air bag material and reduce the effectiveness of the air bag during a deployment.

WARNING!

- **Vehicles equipped with left and right-side curtain air bags must use police cages, which have been approved by the equipment manufacturer, for use in the vehicle.**
- **The area where the side-curtain air bag is located should remain free from any obstructions.**

(Continued)

WARNING! (Continued)

- If your vehicle is equipped with left and right side curtain air bags, care must be taken when installing any type of roof equipment. Drilling and installation of fasteners or other equipment that may interfere with the side-curtain air bags and air bag wiring harness, is not permitted. Furthermore, make sure that no equipment or fasteners are located in the air bag deployment zone.
- Do not place objects or mount equipment in front of the air bag module cover, or in front of the seat areas that may come in contact with a deploying air bag.
- Dash, tunnel or console-mounted equipment should not be placed outside of the specified zone.
- Failure to follow these instructions could result in personal injury.

Air Bag Deployment Zones

There are four zones to be aware of:

1. Driver Air Bag Deployment Zone (Fig. 1), and Driver Air Bag/Steering Wheel Specifications (Fig. 2)
2. Passenger Air Bag Deployment Zone (Fig. 3) and (Fig. 4)
3. Supplemental Side Air Bag Inflatable Curtain (SABIC) Deployment Zone (Fig. 5)
4. Supplemental Seat-Mounted Side Air Bag (SAB) Deployment Zone (Fig. 6)

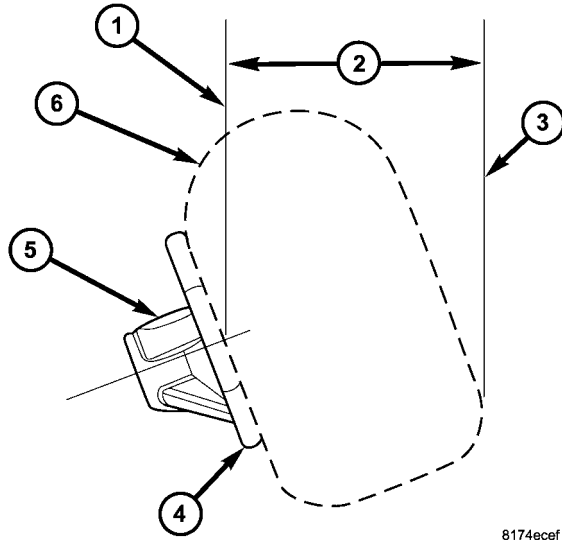

Figure 1

8174ecef

Figure 1 - Driver Air Bag Deployment Zone, depicts the following.

1. Vertical Plane Passing Through Center of Steering Wheel
2. 18.5 in (47 cm)
3. Vertical Plane Passing Through Maximum Rearward Point that the Driver Air Bag Cushion Reaches
4. Steering Wheel
5. Driver Air Bag Retainer/Housing
6. Driver Air Bag Cushion

10 THINGS TO KNOW BEFORE STARTING YOUR VEHICLE

DRIVER AIR BAG/STEERING COLUMN SPECIFICATIONS

DRIVER AIR BAG CUSHION POSITION	
DAB Diameter When Deployed (Full)	26.5 in (67 cm)
DAB Depth When Deployed (Full)	15 in (38 cm)
Maximum Rearward Displacement During Deployment (Fill)	18.5 in (47 cm)
STEERING COLUMN TILT POSITION RANGE	
+/- 2.7 Degrees from Steering Column Tilt Pivot Point	
21.0 Degrees from Vertical is the Nominal Position	

Figure 2 - Driver Air Bag Lateral Deployment Zone, depicts the following.

1. Driver Seating Reference
2. Driver Air Bag Cushion Lateral Deployment Zone, 28 in (71 cm).

2

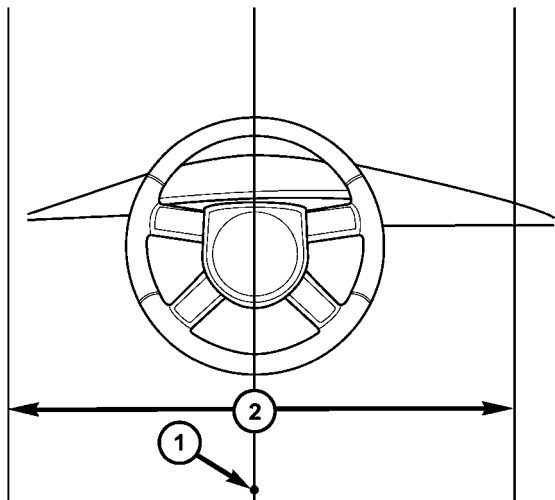

81877152

Figure 2

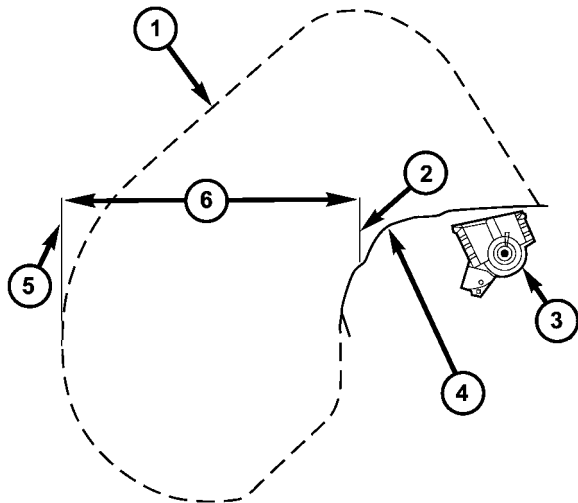

Figure 3 - Passenger Air Bag Deployment Zone, depicts the following.

1. Passenger Air Bag Cushion
2. Vertical Plane from Point of Instrument Panel
3. Passenger Air Bag Module
4. Instrument Panel
5. Vertical Plane Passing Through the Maximum Rearward Point that the Passenger Air Bag Cushion Reaches
6. 18.5 in (47 cm)

8174dd1d

Figure 3

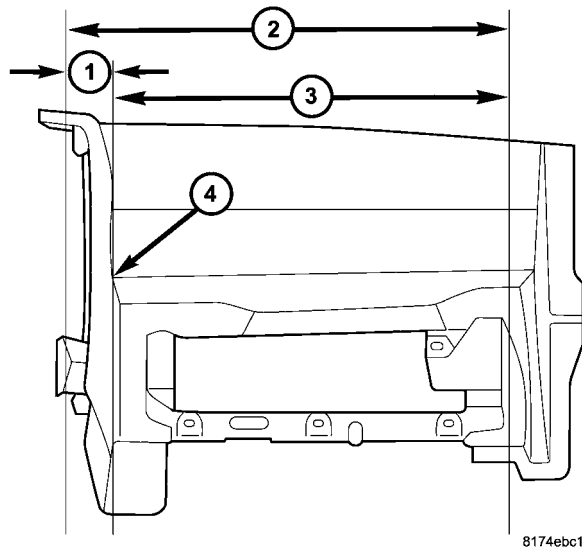
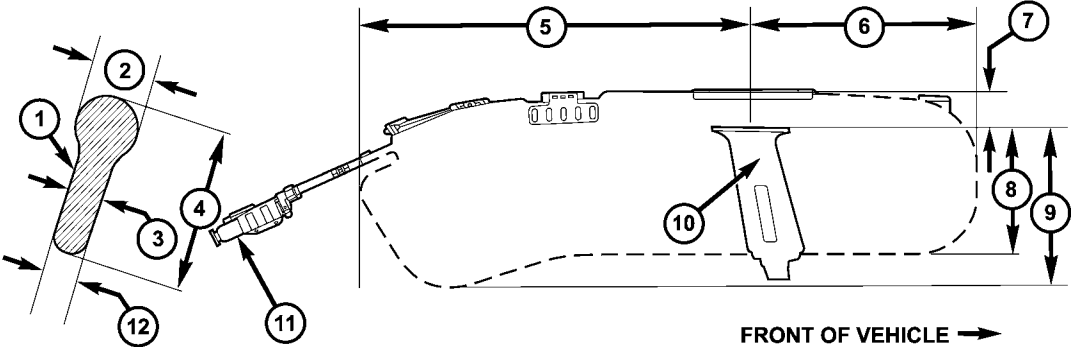

Figure 4

Figure 4 - Passenger Air Bag Lateral Deployment Zone, depicts the following.

1. 2.75 in (7 cm)
2. Passenger Air Bag Cushion Deployment Zone
3. 20 in (52 cm)
4. Reference Point



817523c3

Figure 5

Figure 5 - Supplemental Side Air Bag Inflatable Curtain Air Bag Deployment Zone, depicts the following.

1. Cross-Sectional Area Side View
2. 8.7 in (22 cm)
3. 3.5 in (9 cm)
4. 17.7 in (45 cm)
5. 40.7 in (103.5 cm)
6. 19.8 in (50.5 cm)
7. 3.5 in (9 cm)
8. 14.5 in (37 cm)
9. 16 in (40.5 cm)
10. B-Pillar Trim
11. Side-Curtain Air Bag Inflator Module
12. 3.5 in (9 cm)

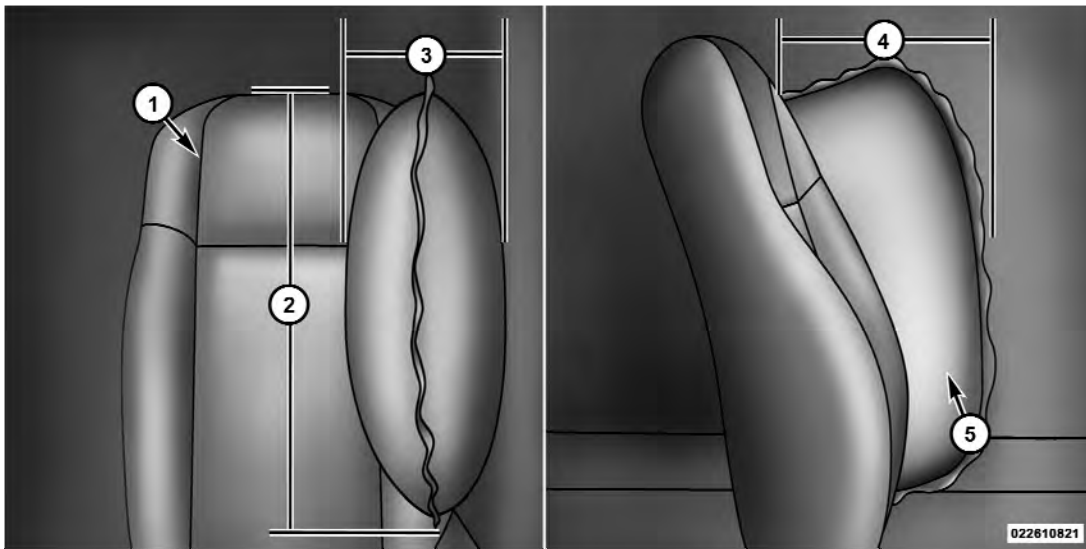

Figure 6

Figure 6 - Supplemental Seat Mounted Side Air Bag Deployment Zone, depicts the following.

1. Front Driver's Seat
2. 177 in (450 cm)
3. 78.7 in (200 cm)
4. 78.7 in (200 cm)
5. Seat-Mounted Air Bag

UNDERSTANDING THE FEATURES OF YOUR VEHICLE

CONTENTS

■ Lights	20	■ Electrical Power Outlets	24
□ Stealth Mode	20	□ Front Power Outlet	24
□ Spot Lights — If Equipped	20	□ Additional Power Leads	25
□ Dome Light — If Equipped	21	■ Console Features	27
■ Adjustable Pedals — If Equipped	22	□ Equipment Mounting Bracket — If Equipped . . .	27

LIGHTS

Stealth Mode

This vehicle is designed for periods of surveillance. The dimmer control is located next to the headlight switch, and is located on the left side of the instrument panel. By rotating the dimmer control to the extreme bottom “OFF” position to “stealth mode” all interior illumination except for PRNDL, odometer, and vehicle critical warning indicators will be cancelled. The PRNDL and odometer will go to the lowest legal limit.



The courtesy (interior) lights are disabled when opening the door, and will operate only by rolling the headlight dimmer switch to the fully upward (detent) position, or by pressing each map light individually.

Spot Lights — If Equipped

This vehicle may be equipped with up to two spotlights. Each spotlight is attached to the A-Pillar. The spotlight

switch is located on the chrome section of the handle. Use this switch to turn on and turn off the spotlight. Rotate and twist the handle to adjust the position of the spotlight.

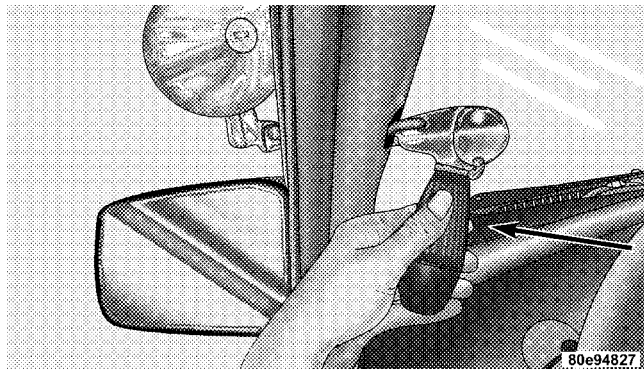

Spotlight Control

Dome Light — If Equipped

The police dome light has three positions. Position one is used for white light, and position two is used for red LED light. Always remember to return the dome light switch to the OFF (center) position when finished using to prevent discharging the vehicle battery.

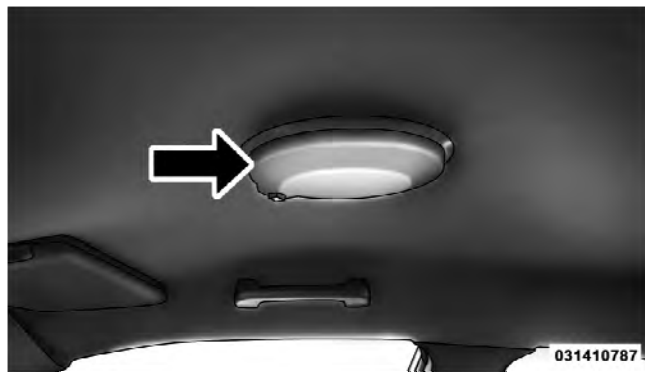

Dome Light

ADJUSTABLE PEDALS — IF EQUIPPED

The adjustable pedals system is designed to allow a greater range of driver comfort for steering wheel tilt and seat position. This feature allows the brake and accelerator pedals to move toward or away from the driver to provide improved position with the steering wheel.

The switch is located on the front side of the driver's seat cushion side shield.

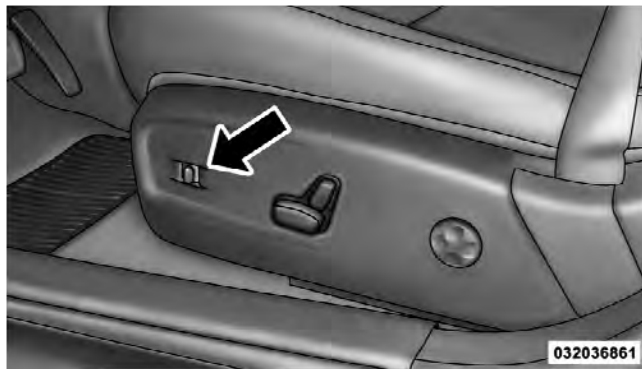

Adjustable Pedal Switch

Press the switch forward to move the pedals forward (toward the front of the vehicle).

Press the switch rearward to move the pedals rearward (toward the driver).

- The pedals can be adjusted with the ignition OFF.
- The pedals can be adjusted while driving.
- The pedals **cannot** be adjusted when the vehicle is in REVERSE or when the Electronic Speed Control System is on. The following messages will be displayed on vehicles equipped with the Electronic Vehicle Information System (EVIC) if the pedals are attempted to be adjusted when the system is locked out (“Adjustable Pedal Disabled — Cruise Control Engaged” or “Adjustable Pedal Disabled — Vehicle In Reverse”).

CAUTION!

Do not place any article under the adjustable pedals or impede its ability to move as it may cause damage to the pedal controls. Pedal travel may become limited if movement is stopped by an obstruction in the adjustable pedal's path.

WARNING!

Do not adjust the pedals while the vehicle is moving. You could lose control and have an accident. Always adjust the pedals while the vehicle is parked.

ELECTRICAL POWER OUTLETS

Front Power Outlet

The front 12 Volt electrical power outlet is located on the center console, and is protected by a fuse. This power outlet is powered directly from the battery (power available at all times). Items plugged into this power outlet may discharge the battery and/or prevent the engine from starting.

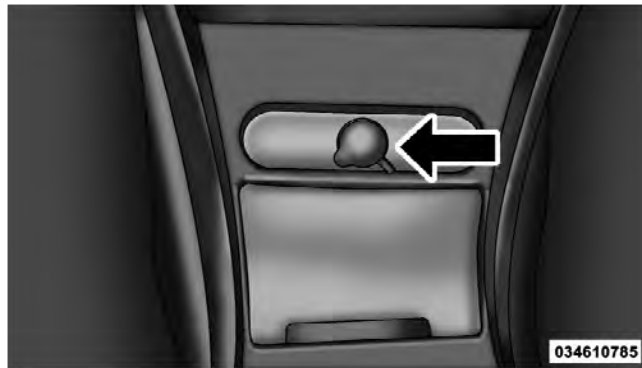

Front Power Outlet

This outlet will also operate a conventional cigar lighter unit.

NOTE: Fuse 18, in the rear Power Distribution Center, not only protects the front power outlet, it also determines whether the battery or the ignition switch will power this outlet. One side of the three-terminal connector that holds Fuse 18 receives battery power, and the other side receives ignition power. To change the power source, install the fuse in either the upper or the lower position of the three-terminal Fuse 18 connector.

Additional Power Leads

There are additional 12-Volt electrical power leads underneath an access cover, located directly under the center console front power outlet. These power leads are protected by fuses located on the passenger side below the glove compartment. Refer to the Police Upfitter's Guide provided with your vehicle, for more details. Carefully pry off the access cover to access the power leads.

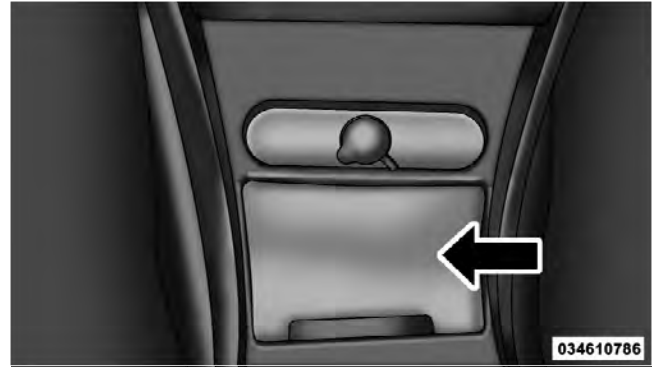

Access Cover

WARNING!

To avoid serious injury or death:

- Do not use a three-prong adapter.
- Do not insert any objects into the receptacles.
- Do not touch with wet hands.
- Close the lid when not in use and while driving the vehicle.
- If this outlet is mishandled, it may cause an electric shock and failure.

CAUTION!

- Many accessories that can be plugged in draw power from the vehicle's battery, even when not in use (i.e., cellular phones, etc.). Eventually, if plugged in long enough, the vehicle's battery will discharge sufficiently to degrade battery life and/or prevent the engine from starting.
- Accessories that draw higher power (i.e., coolers, vacuum cleaners, lights, etc.), will degrade the battery even more quickly. Only use these intermittently and with greater caution.
- After the use of high power draw accessories, or long periods of the vehicle not being started (with accessories still plugged in), the vehicle must be driven a sufficient length of time to allow the alternator to recharge the vehicle's battery.

(Continued)

CAUTION! (Continued)

- Power outlets are designed for accessory plugs only. Do not hang any type of accessory or accessory bracket from the plug. Improper use of the power outlet can cause damage.

CONSOLE FEATURES**Equipment Mounting Bracket — If Equipped**

The equipment mounting bracket is located between the driver's and front passenger's seat. Refer to the Police Upfitter's Guide (www.fleet.chrysler.com) for details.

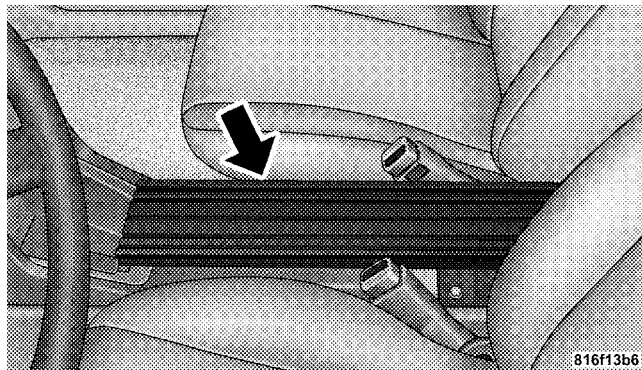

Equipment Mounting Bracket

UNDERSTANDING YOUR INSTRUMENT PANEL

CONTENTS

■ Electronic Vehicle Information Center (EVIC) . . .	30	□ Hour Meter	32
--	----	------------------------	----

ELECTRONIC VEHICLE INFORMATION CENTER (EVIC)

The Electronic Vehicle Information Center (EVIC) features a driver-interactive display that is located in the instrument cluster. Refer



Electronic Vehicle Information Center (EVIC)

This system allows the driver to select a variety of useful information by pressing the switches mounted on the steering wheel. The EVIC consists of the following:

- System status
- Vehicle information warning message displays
- Personal Settings (Customer-Programmable Features)
- Compass display
- Outside temperature display
- Trip computer functions
- Audio mode display

The system allows the driver to select information by pressing the following buttons mounted on the steering wheel.



EVIC Steering Wheel Buttons

UP Button

Press and release the UP button to scroll upward through the main menus (Fuel Economy, Vehicle Info, Tire PSI, Cruise, Messages, Units, System Setup) and sub menus.

DOWN Button

Press and release the DOWN button to scroll downward through the main menus and sub menus.

SELECT Button

Press and release the SELECT button for access to main menus, sub menus or to select a personal setting in the setup menu. Press and hold the SELECT button for two seconds to reset features.

BACK Button

Press the BACK button to scroll back to a previous menu or sub menu.

Hour Meter

1. With the engine running, press the UP or DOWN buttons to scroll through the screens until you reach the Vehicle Info screen.
2. Press the SELECT button.
3. Press the DOWN button until you reach the Engine Hour screen.

STARTING AND OPERATING

CONTENTS

■ Automatic Transmission	34	■ AutoStick®	34
□ Shift Lever	34	□ AutoStick® Operation	35
		■ Vehicle Loading	36

AUTOMATIC TRANSMISSION

Shift Lever

The shift lever is located on the steering column. Refer to the Owner's Manual for specific details about shifting.



Shift Lever

AUTOSTICK®

AutoStick® is a driver-interactive transmission that offers manual gear shifting, to provide you with more control. AutoStick® allows you to maximize engine braking, eliminate undesirable upshifts and downshifts, and improve overall vehicle performance. This system can also provide you with more control during passing, city driving, cold slippery conditions, mountain driving, trailer towing, and many other situations.



AutoStick® Switch

AutoStick® Operation

To activate AutoStick® mode, press and release the AUTOSTICK ON/OFF switch (on the end of the shift lever) at any time while in the DRIVE position. A number

(indicating the current transmission gear) will be illuminated in the transmission gear display (located in the instrument cluster) while AutoStick® mode is active.

In AutoStick® mode, pressing the AUTOSTICK up (+) or down (-) switch allows you to select a higher or lower gear. Pressing the bottom of the switch (-) triggers a downshift (unless it would cause engine overspeeding), and pressing the top of the switch (+) triggers an upshift (unless it would cause engine lugging). The transmission will remain in the current gear until an upshift or downshift is chosen. The transmission will automatically downshift as the vehicle slows to a stop (to prevent engine lugging) and will display the current gear. Pressing the top of the switch (+) when at a stop will allow starting in second gear. After a stop, the driver should manually upshift (+) the transmission as the vehicle is accelerated.

Fully pressing the accelerator pedal while in AutoStick® mode will downshift the transmission as needed for maximum acceleration (3.6L Models Only).

To exit the AutoStick® mode, perform either of the following:

- Press and release the AUTOSTICK ON/OFF switch. The transmission will now operate automatically; shifting between the five available gears. You can shift in or out of AutoStick® mode at any time without taking your foot off the accelerator pedal.
- Bring the vehicle to a complete stop, and place the shift lever in the PARK or NEUTRAL position.

VEHICLE LOADING

The load carrying capacity of your vehicle is shown on the “Vehicle Certification Label.” This label is attached to the rear of the driver’s door. Do not exceed the Gross Vehicle Weight Rating (GVWR) or Gross Axle Weight Rating (GAWR) specified on the label.

While the weights and capacities shown in these tables is intended as supplemental loading information for passenger and luggage, the “Vehicle Certification Label” contains the most current load capacities and therefore, if different, will supersede the data in these tables. Refer to the Owner’s Manual for more information.

Gross Vehicle Weight Rating (GVWR)

Charger Police Vehicles	5,500 lbs (2 495 kg)
-------------------------	----------------------

Vehicle Loading — Charger Police Vehicles

	Front Axle	Rear Axle
Load (Including driver, passengers and cargo)		
3.6L Engine	419 lbs (190 kg)	851 lbs (386 kg)
5.7L Engine	419 lbs (190 kg)	851 lbs (386 kg)
GAWR		
3.6L Engine	2,850 lbs (1 293 kg)	2,850 lbs (1 293 kg)
5.7L Engine	2,850 lbs (1 293 kg)	2,850 lbs (1 293 kg)

WHAT TO DO IN EMERGENCIES

CONTENTS

■ Jacking And Tire Changing	40	□ Jacking And Changing A Tire	43
□ Jack Location/Spare Tire Stowage	40	□ Road Tire Installation	47
□ Preparations For Jacking	42	□ Center Cap Installation — If Equipped	47

JACKING AND TIRE CHANGING**WARNING!**

- Do not attempt to change a tire on the side of the vehicle close to moving traffic. Pull far enough off the road to avoid the danger of being hit when operating the jack or changing the wheel.
- Being under a jacked-up vehicle is dangerous. The vehicle could slip off the jack and fall on you. You could be crushed. Never put any part of your body under a vehicle that is on a jack. If you need to get under a raised vehicle, take it to a service center where it can be raised on a lift.
- Never start or run the engine while the vehicle is on a jack.

(Continued)

WARNING! (Continued)

- The jack is designed to be used as a tool for changing tires only. The jack should not be used to lift the vehicle for service purposes. The vehicle should be jacked on a firm level surface only. Avoid ice or slippery areas.

Jack Location/Spare Tire Stowage

The jack and spare tire are both stowed in the trunk. Follow these steps to access the jack and spare tire.

NOTE: The spare tire must be removed in order to access the jack.

1. Open the trunk.
2. Remove the fastener securing the spare tire.

3. Remove the spare tire.
4. Remove the fastener securing the jack.

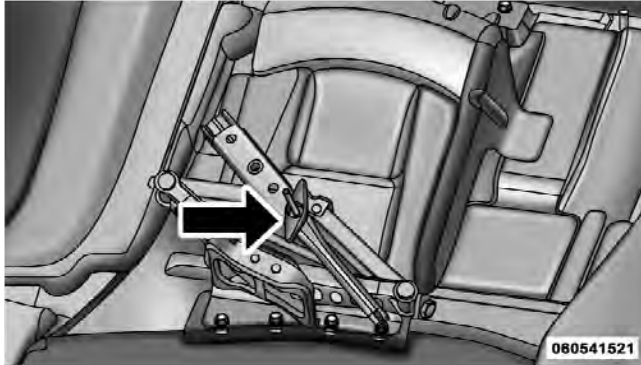

Jack Fastener

5. Remove the scissors jack and lug wrench from the spare wheel as an assembly. Turn the jack screw to the left to loosen the lug wrench, and remove the wrench from the jack assembly.

WARNING!

- A loose tire or jack thrown forward in a collision or hard stop could endanger the occupants of the vehicle. Always stow the jack parts and the spare tire in the places provided.
- Have the deflated (flat) tire repaired or replaced immediately.

Preparations For Jacking

1. Park the vehicle on a firm, level surface as far from the edge of the roadway as possible. Avoid icy or slippery areas.

WARNING!

Do not attempt to change a tire on the side of the vehicle close to moving traffic, pull far enough off the road to avoid being hit when operating the jack or changing the wheel.

2. Turn on the Hazard Warning flasher.
3. Set the parking brake.

4. Place the shift lever into PARK.
5. Turn OFF the ignition.



6. Block the front and rear of the wheel diagonally opposite of the jacking position. For example, if changing the right front tire, block the left rear wheel.

NOTE: Passengers should not remain in the vehicle when the vehicle is being jacked.

Jacking And Changing A Tire

WARNING!

Carefully follow these tire changing warnings to help prevent personal injury or damage to your vehicle:

- Always park on a firm, level surface as far from the edge of the roadway as possible before raising the vehicle.
- Turn on the Hazard Warning flasher.
- Block the wheel diagonally opposite the wheel to be raised.
- Set the parking brake firmly and set an automatic transmission in PARK; a manual transmission in REVERSE.

(Continued)

WARNING! (Continued)

- Never start or run the engine with the vehicle on a jack.
- Do not let anyone sit in the vehicle when it is on a jack.
- Do not get under the vehicle when it is on a jack.
- Only use the jack in the positions indicated and for lifting this vehicle during a tire change.
- If working on or near a roadway, be extremely careful of motor traffic.



Jack Warning Label

CAUTION!

Do not attempt to raise the vehicle by jacking on locations other than those indicated in the Jacking Instructions for this vehicle.

1. Remove the spare tire, jack, and lug wrench.
2. Before raising the vehicle, use the lug wrench to loosen, but not remove, the lug nuts on the wheel with the flat tire. Turn the lug nuts counterclockwise one turn while the wheel is still on the ground.
3. Place the jack underneath the lift area that is closest to the flat tire. Turn the jack screw clockwise to firmly engage the jack saddle with the lift area of the sill flange.

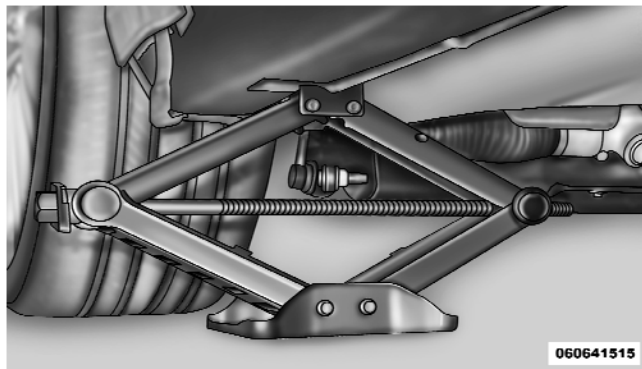

Front Jacking Location

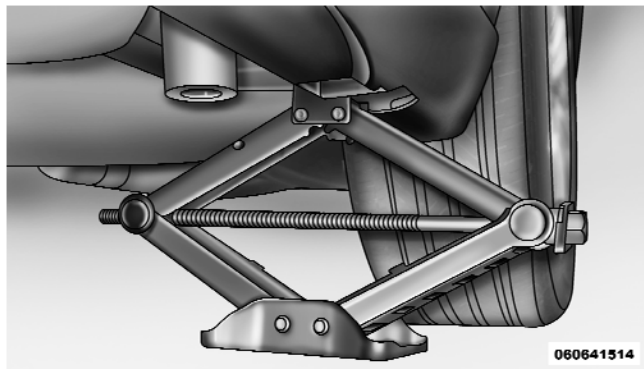

Rear Jacking Location

4. Raise the vehicle just enough to remove the flat tire and install the spare tire.

WARNING!

Raising the vehicle higher than necessary can make the vehicle less stable. It could slip off the jack and hurt someone near it. Raise the vehicle only enough to remove the tire.

5. Remove the lug nuts and tire.
6. Mount the spare tire.

CAUTION!

Be sure to mount the spare tire with the valve stem facing outward. The vehicle could be damaged if the spare tire is mounted incorrectly.

NOTE:

- For vehicles so equipped, do not attempt to install a center cap or wheel cover on the compact spare.
 - Refer to “Starting and Operating/Tires—General Information” in the Owner’s Manual for additional warnings, cautions, and information about the spare tire, its use, and operation.
7. Install the lug nuts with the cone shaped end of the lug nut toward the wheel. Lightly tighten the lug nuts.

WARNING!

To avoid the risk of forcing the vehicle off the jack, do not tighten the lug nuts fully until the vehicle is lowered to the ground.

8. Lower the vehicle to the ground by turning the jack handle counterclockwise.

9. Finish tightening the lug nuts. Push down on the wrench while at the end of the handle for increased leverage. Tighten the lug nuts in a star pattern until each nut has been tightened twice. The correct tightness of each lug nut is 110 ft/lb. (150 N·m). If in doubt about the correct tightness, have them checked with a torque wrench by your authorized dealer or at a service station.

10. Stow the jack, tools and flat tire. Make sure the base of the jack faces the front of the vehicle before tightening down the fastener.

WARNING!

- A loose tire or jack thrown forward in a collision or hard stop could endanger the occupants of the vehicle. Always stow the jack parts and the spare tire in the places provided.
- Have the deflated (flat) tire repaired or replaced immediately.

Road Tire Installation

1. Mount the road tire on the axle.
2. Install the remaining lug nuts with the cone shaped end of the nut toward the wheel. Lightly tighten the lug nuts.

WARNING!

To avoid the risk of forcing the vehicle off the jack, do not tighten the lug nuts fully until the vehicle is lowered to the ground.

3. Lower the vehicle to the ground by turning the jack handle counterclockwise.
4. Finish tightening the lug nuts. Push down on the wrench while at the end of the handle for increased leverage. Tighten the lug nuts in a star pattern until each nut has been tightened twice. The correct tightness of

each lug nut is 110 ft/lbs (150 N·m). If in doubt about the correct tightness, have them checked with a torque wrench by your authorized dealer or service station.

5. After 25 miles (40 km) check the lug nut torque with a torque wrench to ensure that all lug nuts are properly seated against the wheel.

Center Cap Installation — If Equipped

1. Mount the road tire on the axle. For vehicles equipped with center caps, proceed to Step 4.
2. Install two lug nuts on the mounting studs, which are on each side of the stud that is in alignment with the valve stem. Install the lug nuts with the cone shaped end of the nut toward the wheel. Lightly tighten the lug nuts. To avoid the risk of forcing the vehicle off the jack, do not tighten the lug nuts fully until the vehicle is lowered to the ground.

3. Install the remaining lug nuts with the cone shaped end of the nut toward the wheel. Lightly tighten the lug nuts. To avoid the risk of forcing the vehicle off the jack, do not tighten the lug nuts fully until the vehicle is lowered to the ground.

4. Lower the vehicle to the ground by turning the jack handle counterclockwise.

5. Finish tightening the lug nuts. Push down on the wrench while tightening for increased leverage. Alternate lug nuts until each nut has been tightened twice. The correct tightness of each lug nut is 110 ft/lb. (150 N·m). If in doubt about the correct tightness, have them checked with a torque wrench by your authorized dealer or at a service station.

6. For vehicles equipped with center caps, install the center cap by hand. Do not use a hammer or excessive force to install the center cap.

7. Stow the jack, tools, and spare tire. Make sure the base of the jack faces the front of the vehicle before tightening down the fastener.

WARNING!

A loose tire or jack thrown forward in a collision or hard stop could endanger the occupants of the vehicle. Always stow the jack parts and the spare tire in the places provided.

MAINTAINING YOUR VEHICLE

CONTENTS

■ Maintenance Procedures	50	□ Brake System Maintenance	50
------------------------------------	----	--------------------------------------	----

MAINTENANCE PROCEDURES

Police and fleet vehicles are equipped with heavy-duty parts that are designed specifically for the varying demands and unique requirements under which they are operated. This booklet illustrates and describes the operation of unique features and equipment that are either standard or optional on this vehicle. A description of features and equipment no longer available, or not ordered on this vehicle, may also be included. Please disregard any features and equipment described in this manual that is not on this vehicle.

Failure to maintain your vehicle properly may reduce vehicle performance and operational capabilities, adversely affect the safety of you and your passengers, as well as restrict your warranty coverage. Refer to the "Maintenance Schedule" in the Owner's Manual for the proper maintenance intervals.

The manufacturer reserves the right to make changes in design and specifications, and/or make additions to or improvements to its products, without imposing any obligation upon itself to install them on products previously manufactured.

Brake System Maintenance

WARNING!

- **Perform this procedure in a controlled environment, as high speeds and moderate rates of deceleration are necessary in order to complete this procedure. Failure to follow this warning can result in an accident with serious or fatal injuries.**

(Continued)

WARNING! (Continued)

- **In a collision, you and your passengers can suffer much greater injuries if you are not properly buckled up. You can strike the interior of your vehicle or other passengers, or you can be thrown out of the vehicle. Always be sure you and others in your vehicle are buckled up properly.**

All new brake systems have a burnishing (break-in) period. This burnishing (break-in) period will vary according to individual driving habits and driving conditions (e.g., rush hour, city, highway, etc). Smoke and odor associated with brake burnishing is normal. Therefore, we recommend using the following burnish procedure to burnish the heavy-duty brake system on your vehicle.

In a controlled environment, accelerate the vehicle to a speed of 60 mph (97 km/h), maintain this speed for a few seconds, and then apply the brakes for a moderate deceleration, slowing the vehicle to a speed of 10 to 5 mph (16 to 8 km/h). Repeat this sequence 40 times. However, allow 30 seconds between braking maneuvers to cool the brakes. After completing this procedure, allow the brakes to cool completely before driving the vehicle again.

MAINTENANCE SCHEDULES

CONTENTS

■ Maintenance Schedule	54	□ Required Maintenance Intervals	54
----------------------------------	----	--	----

MAINTENANCE SCHEDULE

The Scheduled Maintenance services listed in this manual must be done at the times or mileages specified to protect your vehicle warranty and ensure the best vehicle performance and reliability. More frequent maintenance may be needed for vehicles in severe operating conditions, such as dusty areas and very short trip driving. Inspection and service should also be done anytime a malfunction is suspected.

Required Maintenance Intervals

Refer to the Maintenance Schedule in the Owner's Manual for the rest of the required maintenance intervals.

104,000 Mile (169,000 km) or 78 Months Maintenance Service Schedule

- Replace the spark plugs (5.7L Engine – Police Car Only).

Odometer Reading Date

Repair Order # Dealer Code

Signature, Authorized Service Center

WARNING!

- You can be badly injured working on or around a motor vehicle. Do only service work for which you have the knowledge and the right equipment. If you have any doubt about your ability to perform a service job, take your vehicle to a competent mechanic.
- Failure to properly inspect and maintain your vehicle could result in a component malfunction and effect vehicle handling and performance. This could cause an accident.

INDEX

Adjustable Pedals	22	Jack Location	40
Airbag	7	Jack Operation	43
Airbag Deployment	7	Jacking Instructions	43
Airbag, Window (Side Curtain)	7	Lights	20
Automatic Transmission		Loading Vehicle	36
Autostick	34	Capacities	36
Autostick	34	Locks	6
Brake System	50	Door	6
Hoses	50	Maintenance Procedures	50
Door Locks	6	Maintenance Schedule	54
Electrical Power Outlets	24	Occupant Restraints	7
Electronic Vehicle Information Center (EVIC)	30	Pedals, Adjustable	22
Equipment Mounting Bracket	27	Power	
Information Center, Vehicle	30	Outlet (Auxiliary Electrical Outlet)	24
Introduction	4	Preparation for Jacking	42

Restraints, Occupant	7	Jacking	42,43
Schedule, Maintenance	54	Spare Tire	40
Shifting	34	Transmission	
Automatic Transmission	34	Shifting	34
Side Curtain (Window Airbag)	7	Vehicle Loading	36
Spare Tire	40	Window Airbag (Side Curtain)	7
Supplemental Restraint System - Airbag	7		
Tires			
Changing	43		

INSTALLATION OF RADIO TRANSMITTING EQUIPMENT

Special design considerations are incorporated into this vehicle's electronic system to provide immunity to radio frequency signals. Mobile two-way radios and telephone equipment must be installed properly by trained personnel. The following must be observed during installation.

The positive power connection should be made directly to the battery and fused as close to the battery as possible. The negative power connection should be made to body sheet metal adjacent to the negative battery connection. This connection should not be fused.

Antennas for two-way radios should be mounted on the roof or the rear area of the vehicle. Care should be used in mounting antennas with magnet bases. Magnets may affect the accuracy or operation of the compass on vehicles so equipped.

The antenna cable should be as short as practical and routed away from the vehicle wiring when possible. Use only fully shielded coaxial cable.

Carefully match the antenna and cable to the radio to ensure a low Standing Wave Ratio (SWR).

Mobile radio equipment with output power greater than normal may require special precautions.

All installations should be checked for possible interference between the communications equipment and the vehicle's electronic systems.



STICK WITH THE SPECIALISTS®

Chrysler Group LLC
12D483-226-AB



2nd Edition

Printed in U.S.A.