



RAM

DAKOTA USER GUIDE



2011

If you are the first registered owner of your vehicle, you may obtain a complimentary printed copy of the Owner's Manual, Navigation/Media Center Manuals or Warranty Booklet by calling 1-866-726-4636 (U.S.) or 1-800-387-1143 (Canada) or by contacting your dealer.

The driver's primary responsibility is the safe operation of the vehicle. Driving while distracted can result in loss of vehicle control, resulting in a collision and personal injury. Chrysler Group LLC strongly recommends that the driver use extreme caution when using any device or feature that may take their attention off the road. Use of any electrical devices such as cell phones, computers, portable radios, vehicle navigation or other devices by the driver while the vehicle is moving is dangerous and could lead to a serious collision. Texting while driving is also dangerous and should never be done while the vehicle is moving. If you find yourself unable to devote your full attention to vehicle operation, pull off the road to a safe location and stop your vehicle. Some States or Provinces prohibit the use of cellular telephones or texting while driving. It is always the driver's responsibility to comply with all local laws.

IMPORTANT: This User Guide is intended to familiarize you with the important features of your vehicle. The DVD enclosed contains your Owner's Manual, Navigation/Media Center Manuals, Warranty Booklets, Tire Warranty and 24-Hour Towing Assistance (new vehicles purchased in the U.S.) or Roadside Assistance (new vehicles purchased in Canada) in electronic format. We hope you find it useful. Replacement DVD kits may be purchased by visiting www.techauthority.com. Copyright 2011 Chrysler Group LLC.

TABLE OF CONTENTS

INTRODUCTION/WELCOME

Welcome From Chrysler Group LLC 2

CONTROLS AT A GLANCE

Driver Cockpit 4

Instrument Cluster 6

GETTING STARTED

Key FOB 8

Remote Start 8

Theft Alarm 9

Seat Belt 9

Supplemental Restraint System (SRS) —

Airbags 10

Child Restraints 11

Front Seats 14

Heated Seats 16

Tilt Steering Column 17

OPERATING YOUR VEHICLE

Turn Signals/Wiper/Washer/High

Beams Lever 18

Headlight Switch 19

Speed Control 20

Climate Controls 21

Wind Buffeting 21

ELECTRONICS

Non-Touch-Screen Radios 22

Steering Wheel Audio Controls 25

Uconnect™ Phone 25

Uconnect™ Voice Command 27

Programmable Features 28

Universal Garage Door Opener

(HomeLink®) 29

Power Outlets 31

OFF-ROAD CAPABILITIES

Four-Wheel Drive Operation 32

UTILITY

Rear Crate 'N Go® Storage 33

Rear Cargo Area Utility Rails 33

Tailgate 33

Trailer Towing Weights (Maximum

Trailer Weight Ratings) 34

Recreational Towing (Behind

Motorhome, Etc.) 34

Brake/Transmission Interlock

System 36

WHAT TO DO IN EMERGENCIES

24-Hour Towing Assistance 37

Instrument Cluster Warning Lights . . 37

If Your Engine Overheats 40

Jacking And Tire Changing 42

Jump-Starting 47

Emergency Tow Hooks 49

Towing A Disabled Vehicle 50

Freeing A Stuck Vehicle 51

Event Data Recorder (EDR) 52

MAINTAINING YOUR VEHICLE

Opening The Hood 53

Engine Compartment 54

Fluids And Capacities 56

Maintenance Chart 58

Fuses 61

Tire Pressures 64

Wheel And Wheel Trim Care 64

Exterior Bulbs 65

CONSUMER ASSISTANCE

Chrysler Group LLC Customer Center . 66

Chrysler Canada Inc. Customer Center 66

Assistance For The Hearing Impaired . 66

Publications Ordering 66

Reporting Safety Defects In

The 50 United States And

Washington, D.C. 67

MOPAR ACCESSORIES

Authentic Accessories By MOPAR® . . 68

INDEX 69

INTRODUCTION/WELCOME

WELCOME FROM CHRYSLER GROUP LLC

Congratulations on selecting your new Chrysler Group LLC vehicle. Be assured that it represents precision workmanship, distinctive styling, and high quality - all essentials that are traditional to our vehicles.

Your new Chrysler Group LLC vehicle has characteristics to enhance the driver's control under some driving conditions. These are to assist the driver and are never a substitute for attentive driving. They can never take the driver's place. Always drive carefully.

Your new vehicle has many features for the comfort and convenience of you and your passengers. Some of these should not be used when driving because they take your eyes from the road or your attention from driving. Never text while driving or take your eyes more than momentarily off the road.

This guide illustrates and describes the operation of features and equipment that are either standard or optional on this vehicle. This guide may also include a description of features and equipment that are no longer available or were not ordered on this vehicle. Please disregard any features and equipment described in this guide that are not available on this vehicle. Chrysler Group LLC reserves the right to make changes in design and specifications and/or make additions to or improvements to its products without imposing any obligation upon itself to install them on products previously manufactured.

This User Guide has been prepared to help you quickly become acquainted with the important features of your vehicle. It contains most things you will need to operate and maintain the vehicle, including emergency information.

The DVD includes a computer application containing detailed owner's information which can be viewed on a personal computer or MAC computer. The multimedia DVD also includes videos which can be played on any standard DVD player (including the Media Center Touch-Screen Radios). Additional DVD operational information is located on the back of the DVD sleeve.

For complete owner information, refer to your Owner's Manual on the DVD in the owner's kit provided at the time of new vehicle purchase. For your convenience, the information contained on the DVD may also be printed and saved for future reference.

Chrysler Group LLC is committed to protecting our environment and natural resources. By converting from paper to electronic delivery for the majority of the user information for your vehicle, together we greatly reduce the demand for tree-based products and lessen the stress on our environment.

Vehicles Sold In Canada

With respect to any vehicles sold in Canada, the name Chrysler Group LLC shall be deemed to be deleted and the name Chrysler Canada Inc. used in substitution therefore.

INTRODUCTION/WELCOME

WARNING!

- Pedals that cannot move freely can cause loss of vehicle control and increase the risk of serious personal injury.
- Always make sure that objects cannot fall into the driver foot well while the vehicle is moving. Objects can become trapped under the brake pedal and accelerator pedal causing a loss of vehicle control.
- Failure to properly follow floor mat installation or mounting can cause interference with the brake pedal and accelerator pedal operation causing loss of control of the vehicle.
- Never use the 'PARK' position as a substitute for the parking brake. Always apply the parking brake fully when parked to guard against vehicle movement and possible injury or damage.
- Refer to your Owner's Manual on the DVD for further details.

USE OF AFTERMARKET PRODUCTS (ELECTRONICS)

The use of aftermarket devices including cell phones, MP3 players, GPS systems, or chargers may affect the performance of on-board wireless features including Keyless Enter-N-Go and Remote Start range. If you are experiencing difficulties with any of your wireless features, try disconnecting your aftermarket devices to see if the situation improves. If your symptoms persist, please see an authorized dealer.

CHRYSLER, DODGE, JEEP, RAM TRUCK, ATF+4, MOPAR and Uconnect are registered trademarks of Chrysler Group LLC.

COPYRIGHT ©2011 CHRYSLER GROUP LLC



CONTROLS AT A GLANCE

DRIVER COCKPIT



CONTROLS AT A GLANCE



**Transmission
Gear Selector**

**Audio System
(non-touch-
screen radio shown)**

Climate Control

Power Outlet/Cigar Lighter









***If Equipped**

CONTROLS AT A GLANCE





INSTRUMENT CLUSTER

Warning Lights

-  - Low Fuel Warning Light
-  - Charging System Light**
-  - Oil Pressure Warning Light**
-  - Anti-Lock Brake (ABS) Light**
-  - Airbag Warning Light**
-  - Electronic Throttle Control (ETC) Light
-  - Tire Pressure Monitoring System (TPMS) Light
-  - Engine Temperature Warning Light
-  - Transmission Temperature Warning Light
-  - Seat Belt Reminder Light

BRAKE

-  - Brake Warning Light**
-  - Malfunction Indicator Light (MIL)**
-  - SVC (Service) 4WD Indicator Light

(See page 37 for more information.)

CONTROLS AT A GLANCE

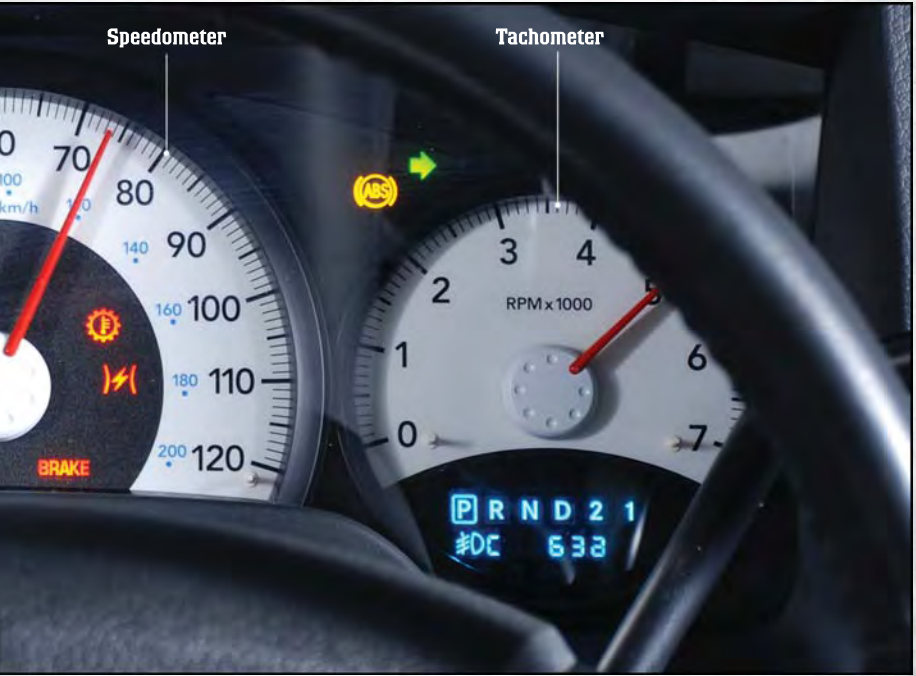

Indicators



- Turn Signal Indicators



- High Beam Indicator



- Front Fog Light Indicator



- Vehicle Security Indicator*



- TOW/HAUL Indicator



- Cruise Indicator



- 4WD Indicator



- 4WD LOW Indicator

- Cargo Lamp Indicator

Odometer Messages

door - Door Ajar

gASCAP - Fuel Cap Fault

LoW WASH- Low Washer Fluid

LoW tIrE - Low Tire Pressure

noFUSE* - Fuse Fault

CHAngE OIL* - Change Engine Oil

* If equipped

** Bulb Check with Key On

GETTING STARTED

KEY FOB



Locking And Unlocking The Doors

- Press the LOCK button once to lock all the doors. Press the UNLOCK button once to unlock the driver's door only and twice within five seconds to unlock all the doors.
- All doors can be programmed to unlock on the first press of the UNLOCK button. Refer to Programmable Features in this guide.

Panic Alarm

- Press the PANIC button once to turn the panic alarm on.
- Wait approximately three seconds and press the button a second time to turn the panic alarm off.

WARNING!

Leaving unattended children in a vehicle is dangerous for a number of reasons. A child or others could be severely injured or killed. Children should be warned not to touch the parking brake, brake pedal, or the shift lever. Do not leave the key in the ignition. A child could operate power windows, other controls, or move the vehicle.

REMOTE START

- Press the REMOTE START button  twice within five seconds. Pressing the REMOTE START button a third time shuts the engine off.
- To drive the vehicle, press the UNLOCK button, insert the key in the ignition and turn to the ON/RUN position.
- With remote start, the engine will only run for 15 minutes (timeout) unless the ignition key is placed in the ON/RUN position.
- The vehicle must be started with the key after two consecutive timeouts.

GETTING STARTED

WARNING!

- Do not start or run an engine in a closed garage or confined area. Exhaust gas contains Carbon Monoxide (CO) which is odorless and colorless. Carbon Monoxide is poisonous and can cause serious injury or death when inhaled.
- Keep Key Fob transmitters away from children. Operation of the Remote Start System, windows, door locks or other controls could cause serious injury or death.

THEFT ALARM

To Arm

- Press the Key Fob LOCK button or the power door lock switch while the door is open.

To Disarm

- Press the Key Fob UNLOCK button and turn the ignition to the ON/RUN position.

SEAT BELT

- Be sure everyone in your vehicle is in a seat and using a seat belt properly.
- Position the lap belt across your thighs, below your abdomen. To remove slack in the lap portion, pull up a bit on the shoulder belt. To loosen the lap belt if it is too tight, tilt the latch plate and pull on the lap belt. A snug belt reduces the risk of sliding under the belt in a collision.
- Position the shoulder belt on your chest so that it is comfortable and not resting on your neck. The retractor will withdraw any slack in the belt.
- A shoulder belt placed behind you will not protect you from injury during a collision. You are more likely to hit your head in a collision if you do not wear your shoulder belt. The lap and shoulder belt are meant to be used together.
- A belt that is too loose will not protect you properly. In a sudden stop you could move too far forward, increasing the possibility of injury. Wear your seat belt snugly.
- A frayed or torn belt could rip apart in a collision and leave you with no protection. Inspect the belt system periodically, checking for cuts, frays, or loose parts. Damaged parts must be replaced immediately. Do not disassemble or modify the system. Seat belt assemblies must be replaced after a collision if they have been damaged (bent retractor, torn webbing, etc.).
- The seat belts for both front seating positions are equipped with pretensioning devices that are designed to remove slack from the seat belt in the event of a collision.
- A deployed pretensioner or a deployed airbag must be replaced immediately.

GETTING STARTED

WARNING!

In a collision, you and your passengers can suffer much greater injuries if you are not buckled up properly. You can strike the interior of your vehicle or other passengers, or you can be thrown out of the vehicle. Always be sure you and others in your vehicle are buckled up properly.

SUPPLEMENTAL RESTRAINT SYSTEM (SRS) — AIRBAGS

- This vehicle has Advanced Front Airbags for both the driver and right front passenger as a supplement to the seat belt restraint system. The Advanced Front Airbags will not deploy in every type of collision.
- Advanced Front Airbags are designed to provide additional protection by supplementing the seat belts in certain frontal collisions depending on the severity and type of collision. Advanced Front Airbags are not expected to reduce the risk of injury in rear, side, or rollover collisions.
- This vehicle may be equipped with Supplemental Side Airbag Inflatable Curtains to protect the driver, front and rear passengers sitting next to a window.
- If the Airbag Warning Light  is not on during starting, stays on, or turns on while driving, have the vehicle serviced by an authorized service center immediately.
- Refer to the Owner's Manual on the DVD for further details regarding the Supplemental Restraint System (SRS).

WARNING!

- Relying on the airbags alone could lead to more severe injuries in a collision. The airbags work with your seat belt to restrain you properly. In some collisions, the airbags won't deploy at all. Always wear your seat belts even though you have airbags.
- Being too close to the steering wheel or instrument panel during Advanced Front Airbag deployment could cause serious injury, including death. Airbags need room to inflate. Sit back, comfortably extending your arms to reach the steering wheel or instrument panel.
- Supplemental Side Airbag Inflatable Curtains need room to inflate. Do not lean against the door or window. Sit upright in the center of the seat.
- Being too close to the Supplemental Side Airbag Inflatable Curtain during deployment could cause you to be severely injured or killed.
- Do not drive your vehicle after the airbags have deployed. If you are involved in another collision, the airbags will not be in place to protect you.
- After any collision, the vehicle should be taken to an authorized dealer immediately.

GETTING STARTED

CHILD RESTRAINTS

- Children 12 years and under should ride properly buckled up in a rear seat, if available. According to crash statistics, children are safer when properly restrained in the rear seats rather than in the front.
- Every state in the United States and all Canadian provinces require that small children ride in proper restraint systems. This is the law, and you can be prosecuted for ignoring it.

Installing The LATCH - Compatible Child Restraint System

- Your vehicle is equipped with the child restraint anchorage system called LATCH, which stands for Lower Anchors and Tether for CHildren.

Extended Cab

- The Extended Cab right rear (if equipped with a rear seat) passenger seating position has lower anchorages that is capable of accommodating a LATCH compatible child seat having flexible, webbing mounted lower attachments.

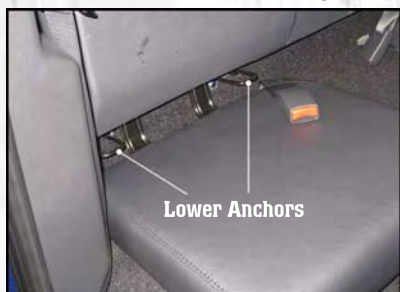

- Loosen the child seat adjusters on the lower straps and tether straps so that you can attach the hook or connector to the lower and tether anchorages more easily.

- Attach the lower hooks or connectors over the top of the anchorage bars, pushing aside the seat cover material. You will easily feel the anchorage bars if you run your finger along the intersection of the seatback and seat cushion surfaces.

Tether Straps at the Rear Passenger Seat (Extended Cab)

- Route the child restraint tether strap through the routing loop, located directly behind the child restraint. The routing loops are located behind the flip-down door on the cab back panel (padded bolster).

GETTING STARTED



- Route the tether strap across to the center tether anchorage. The center tether is located behind the slide door in the center of the vehicle, between the two seating positions.
- Remove the slack in the tether strap so that the anchor strap is pulled tight.

Crew Cab

- The Crew Cab second row seat has lower anchorages that are capable of accommodating LATCH compatible child seats having flexible, webbing mounted lower attachments at all three seating positions.

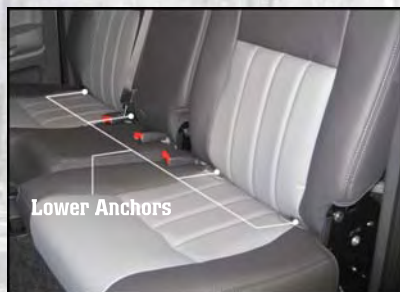

- Child seats with fixed lower attachments must be installed in the outboard positions only.
 - **Never** install LATCH-compatible child seats such that two seats share a common lower anchorage.
 - Loosen the child seat adjusters on the lower straps and tether straps so that you can attach the hook or connector to the lower and tether anchorages more easily.
- Attach the lower hooks or connectors over the top of the anchorage bars, pushing aside the seat cover material. You will easily feel the anchorage bars if you run your finger along the intersection of the seatback and seat cushion surfaces.

GETTING STARTED

Tether Straps at the Rear Passenger Seat (Crew Cab)

- Route the child restraint tether strap over the seatback and under the head restraint (for outboard seating position only) and through the anchor strap outer loop (webbing material loop) located directly behind the child restraint.

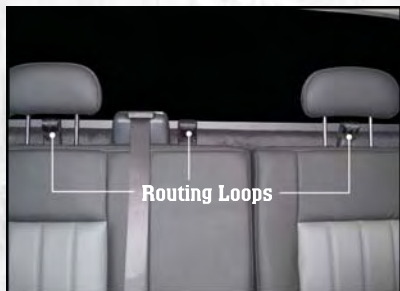

- Connect the tether strap hook to the anchor loop in the ADJACENT seating position.
- Remove the slack in the tether strap so that both anchor straps are pulled tight.

NOTE: Two anchors must be used for any of the three seating positions.

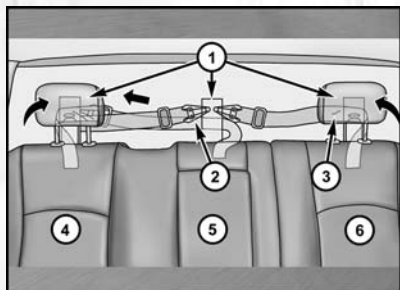

1. Anchor Loops
2. Snap Hook
3. Tether Strap
4. Passenger's Side Rear Child Seat
5. Rear Center Child Seat
6. Driver's Side Rear Child Seat

Installing The Child Restraint Using The Vehicle Seat Belts

- To install a child restraint, first, pull enough of the seat belt webbing from the retractor to route it through the belt path of the child restraint and slide the latch plate into the buckle.
- Next, extract all the seat belt webbing out of the retractor and then allow the belt to retract into the retractor. Finally, pull on any excess webbing to tighten the lap portion around the child restraint. Any seat belt system will loosen with time, so check the belt occasionally, and pull it tight if necessary.
- Once you have completed securing the child restraint with the seat belt, secure the top tether strap as described on the previous pages.

GETTING STARTED

WARNING!

- In a collision, an unrestrained child, even a tiny baby, can become a projectile inside the vehicle. The force required to hold even an infant on your lap could become so great that you could not hold the child, no matter how strong you are. The child and others could be severely injured or killed. Any child riding in your vehicle should be in a proper restraint for the child's size.
- Improper installation of a child restraint to the LATCH anchorages can lead to failure of an infant or child restraint. The child could be severely injured or killed. Follow the manufacturer's directions exactly when installing an infant or child restraint.
- An incorrectly anchored tether strap could lead to increased head motion and possible injury to the child. Use only the anchor positions directly behind the child seat to secure a child restraint top tether strap.
- Rearward-facing child seats must never be used in the front seat of a vehicle with a front passenger airbag. An airbag deployment could cause severe injury or death to infants in this position.

FRONT SEATS

Power Seat — Driver's Side Only

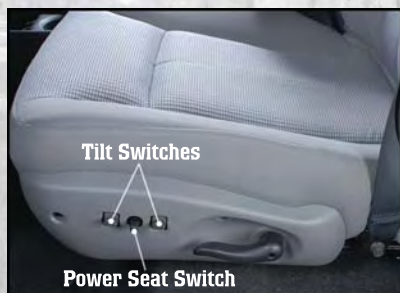

- The power seat controls are located on the outboard side of the driver's seat cushion.
- The power seat switch controls the forward, backward, up, or down adjustment.
- The two tilt switches control the tilt up or down adjustment.

GETTING STARTED

Manual Seat Adjustment

Forward/Rearward



- Lift up on the adjusting bar located at the front of the seat near the floor and release bar to lock seat at the desired position.

Lumbar Support/Recliner



- Rotate the lumbar knob, located on the left-side of the driver's seat, to increase or decrease the amount of lumbar support.
- Lean forward slightly, lift the recline lever located on the outboard side of the seat, then push back to the desired position and release the lever.
- Lean forward and lift the recline lever to return the seatback to its normal position.

CAUTION!

Do not place any article under a power seat or impede its ability to move as it may cause damage to the seat controls. Seat travel may become limited if movement is stopped by an obstruction in the seat's path.

WARNING!

- Adjusting a seat while the vehicle is moving is dangerous. The sudden movement of the seat could cause you to lose control. The seat belt might not be properly adjusted, and you could be severely injured or killed. Only adjust a seat while the vehicle is parked.

(Continued)

GETTING STARTED

WARNING! *(Continued)*

- Do not ride with the seatback reclined so that the shoulder belt is no longer resting against your chest. In a collision, you could slide under the seat belt and be severely injured or killed. Use the recliner only when the vehicle is parked.

HEATED SEATS

Front Heated Seats

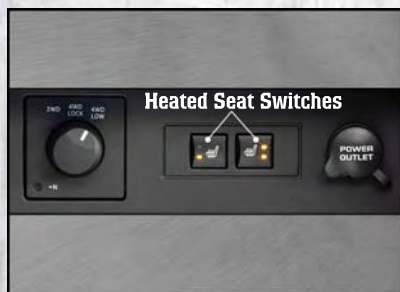

- The heated seat switches are located on the center of the instrument panel.
- After turning the ignition ON, press the switch once to select High-level heating. Press the switch a second time to select Low-level heating. Press the switch a third time to shut the heating elements Off.

- If the High-level setting is selected, the system will automatically switch to Low-level after approximately 30 minutes. The Low-level setting will turn Off automatically after approximately 30 minutes.

WARNING!

- Persons who are unable to feel pain to the skin because of advanced age, chronic illness, diabetes, spinal cord injury, medication, alcohol use, exhaustion or other physical conditions must exercise care when using the seat heater. It may cause burns even at low temperatures, especially if used for long periods of time.
- Do not place anything on the seat that insulates against heat, such as a blanket or cushion. This may cause the seat heater to overheat. Sitting in a seat that has been overheated could cause serious burns due to the increased surface temperature of the seat.

GETTING STARTED

TILT STEERING COLUMN



Tilt Lever

- The tilt lever is located on the steering column, below the turn signal lever.
- Pull the lever toward the steering wheel to unlock the steering column.
- With one hand firmly on the steering wheel, move the steering column up or down as desired.
- Push the lever away from the steering wheel to lock the column firmly in place.

WARNING!

Tilting the steering column while the vehicle is moving is dangerous. Without a stable steering column, you could lose control of the vehicle and have a collision. Adjust the column only while the vehicle is stopped. Be sure the column is locked before driving.

OPERATING YOUR VEHICLE

TURN SIGNALS/WIPER/WASHER/HIGH BEAMS LEVER

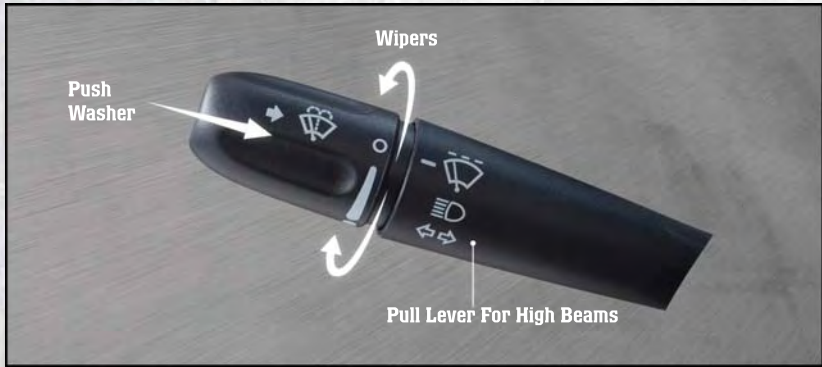

Turn Signals/Lane Change Assist

- Tap the lever up or down once and the turn signal (right or left) will flash three times and automatically turn off.

Wipers

Intermittent, Low And High Operation

- Rotate the end of the lever to the first detent position for one of five intermittent settings, the second detent for low wiper operation and the third detent for high wiper operation.

Washer Operation

- Push the end of the lever inward to the second detent and hold for as long as spray is desired.

High Beams

- Pull the lever toward you to activate the high beams.
- A high beam symbol will illuminate in the cluster to indicate the high beams are on.

NOTE: For safe driving, turn off the high beams when oncoming traffic is present to prevent headlight glare and as a courtesy to other motorists.

OPERATING YOUR VEHICLE

HEADLIGHT SWITCH

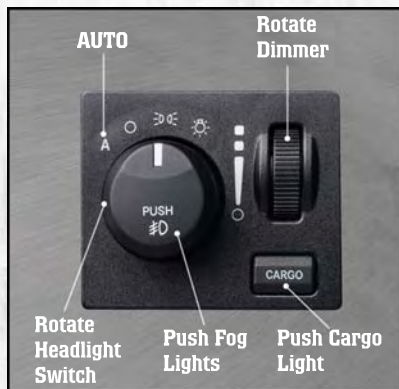

Automatic Headlights/Parking Lights/Headlights

- Rotate the headlight switch, located on the instrument panel to the left of the steering wheel, to the first detent for parking lights and to the second detent for headlights.
- With the parking lights or low beam headlights on, push the headlight switch once for fog lights.
- Rotate the headlight switch to "A" for AUTO headlights.
- When set to "A" (AUTO), the system automatically turns the headlights on or off based on ambient light levels.

Instrument Panel Dimmer

- Rotate the dimmer control to the extreme bottom position to fully dim the instrument panel lights and prevent the interior lights from illuminating when a door is opened.
- Rotate the dimmer control up to increase the brightness of the instrument panel when the parking lights or headlights are on.
- Rotate the dimmer control up to the next detent position to fully brighten the odometer and radio when the parking lights or headlights are on. Refer to your Media Center/Radio User Manual on the DVD for display dimming.
- Rotate the dimmer control up to the last detent position to turn on the interior lighting.

Cargo Light

- The cargo light is strategically placed lighting that helps illuminate the bed area of the truck. A cargo light symbol will illuminate in the cluster to indicate the light is on.
- Push the button to turn ON/OFF the cargo lighting.

OPERATING YOUR VEHICLE

SPEED CONTROL



- The speed control switches are located on the steering wheel.

Cruise ON/OFF

- Push the ON/OFF switch to activate the Speed Control.
- CRUISE will appear in the instrument cluster to indicate the Speed Control is on.
- Push the ON/OFF switch a second time to turn the system off.

Set

- With the Speed Control on, push and release the SET switch to set a desired speed.

Accel/Decel

- Push and hold the RESUME/ACCEL switch to accelerate or push and hold the DECEL switch to decelerate the vehicle; release the switch to save the new set speed.
- Once a speed is set, pushing the RESUME/ACCEL switch once or the DECEL switch once will increase or decrease the set speed approximately 1 mph (2 km/h).

Resume

- To resume a previously selected set speed in memory, push the RESUME/ACCEL switch and release.

Cancel

- Push the CANCEL switch, or apply the brakes or clutch, to cancel the set speed and maintain the set speed memory.
- Push the ON/OFF switch to turn the system off and erase the set speed memory.

OPERATING YOUR VEHICLE

CLIMATE CONTROLS

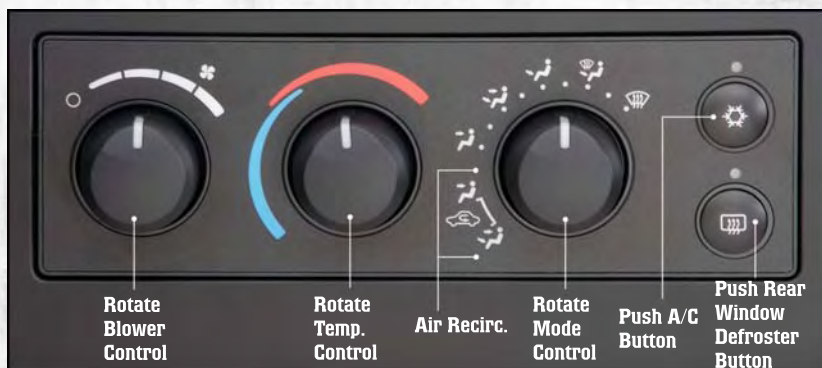

Air Recirculation

- Use recirculation for maximum A/C operation.
- For window defogging, turn the recirculation off.
- Recirculation is not allowed in defrost, floor, defrost/floor (mix) modes.

WIND BUFFETING

- Wind buffeting can be described as a helicopter-type percussion sound. If buffeting occurs with the rear windows open, adjust the front and rear windows together.

ELECTRONICS

NON-TOUCH-SCREEN RADIOS

Media Center 130 (Sales Code RES)



Media Center 130 with Satellite Radio (Sales Code RES + RSC)



Media Center 230 (Sales Code REQ)



NOTE: Your radio may not be equipped with the Uconnect™ Voice Command and Uconnect™ Phone features. To determine if your radio has these features, press the Voice Command button on the radio. You will hear a voice prompt if you have the feature, or see a message on the radio stating “Uconnect Phone not available” if you do not.

- Your radio has many features that add to the comfort and convenience of you and your passengers. Some of these radio features should not be used when driving because they take your eyes from the road or your attention from driving.
- The radio sales code is located on the lower right side of the radio faceplate.

Seek Up/Down Buttons

- Press to seek through radio stations in AM, FM, or SAT bands. Seek through tracks in CD mode.
- Hold either button to bypass stations without stopping.

Audio Settings

- Press the TUNE/SCROLL control knob and BASS, MID, TREBLE, BALANCE and FADE will display. Rotate the TUNE/SCROLL control knob to select the desired setting.

ELECTRONICS

Audio Jack

- The Audio Jack allows a portable device, such as an MP3 player or a cassette player, to be plugged into the radio and utilize the vehicle's audio system, using a 3.5 mm audio cable, to amplify the source and play through the vehicle speakers.
- Pressing the AUX button will change the mode to auxiliary device if the Audio Jack is connected, allowing the music from your portable device to play through the vehicle's speakers.
- The functions of the portable device are controlled using the device buttons. The volume may be controlled using the radio or portable device.

Clock Setting

- Press and hold the TIME button until the hours blink; turn the TUNE/SCROLL control knob to set the hours.
- Press the TUNE/SCROLL control knob until the minutes begin to blink; turn the TUNE/SCROLL control knob to set the minutes.
- Press the TUNE/SCROLL control knob to save the time change.
- To exit, press any button/knob or wait five seconds.

Store Radio Presets

- Press the SET/RND button once and SET 1 will show in the display. Then select the button (1–6).
- A second station may be added to each push button. Press the SET/RND button twice and SET 2 will show in the display, then select button (1–6).

How To Load Multiple CDs/DVDs

Media Center 230 (Sales Code REQ) Only

- Press the LOAD button and then press the button with the corresponding number (1–6) where the CD will be loaded. The radio will display PLEASE WAIT and prompt when to INSERT DISC.
- After the radio displays INSERT DISC, insert the CD into the player. The radio display will show LOADING DISC when the disc is loading and "READING DISC" when the radio is reading the disc.
- Press the eject button and then the corresponding number (1–6) to eject the desired disc.

STEERING WHEEL AUDIO CONTROLS



Steering Wheel
Audio Controls

- The steering wheel audio controls are located on the rear surface of the steering wheel.

Right Switch

- Press the switch up or down to increase or decrease the volume.
- Press the button in the center to change modes AM/FM/CD/SAT.

Left Switch

- Press the switch up or down to search for the next listenable station or select the next or previous CD track.

- Press the button in the center to select the next preset station (radio) or to change CDs if equipped with a CD Changer.

Uconnect™ Phone

- To determine if your vehicle is equipped with Uconnect™ Phone, press the Uconnect™ Phone button . If your vehicle has this feature, after a couple seconds you will hear a voice prompt. If not, you will see a message on the radio "Uconnect phone not available".
- The Uconnect™ Phone is a voice-activated, hands-free, in-vehicle communications system with Voice Command Capability (see Voice Command section).
- The Uconnect™ Phone allows you to dial a phone number with your mobile phone using simple voice commands.
- For vehicles equipped with Video Entertainment System (VES)™, refer to the Uconnect™ Phone section of the Uconnect™ User's Manual on the DVD for further details.
- For vehicles not equipped with VES™, refer to your vehicle Owner's Manual on the DVD for further details.

NOTE: The Uconnect™ Phone requires a mobile phone equipped with the Bluetooth® Hands-Free Profile, Version 0.96 or higher. For Uconnect™ customer support, call 1-877-855-8400 or visit www.ramtrucks.com/uconnect.

Phone Pairing

NOTE: Pairing is a one-time initial setup before using the phone. You will also need to follow the Bluetooth® instructions in your cell phone user guide to complete the phone pairing setup.

- Press the Phone button  to begin.
- Wait for the "ready" prompt and BEEP.

ELECTRONICS

- (After the BEEP), say “Uconnect setup”.
- (After the BEEP), say “phone pairing”.
- (After the BEEP), say “pair a phone”.
- Follow the audible prompts.
- You will be asked to enter a four-digit Personal Identification Number (PIN), which you will later need to enter into your mobile phone. You can enter any four-digit PIN. You will not need to remember this PIN after the initial pairing process.
- You will then be prompted to give the phone pairing a name (each phone paired should have a unique name).
- Next you will be asked to give this new pairing a priority of 1 thru 7 (up to seven phones may be paired); 1 is the highest and 7 is the lowest priority. The system will only connect to the highest priority phone that exists within the proximity of the vehicle.



Making A Phone Call

- Press the Phone button .
- (After the BEEP), say “dial” (or “call” a name).
- (After the BEEP), say number (or name).

Phonebook Edit

- Press the Phone button .
- (After the BEEP), say “phonebook”.
- (After the BEEP), say “new entry” or “list names” or “delete”.
- Follow the prompts.

Receiving A Call – Accept (And End)

- When an incoming call rings/is announced on Uconnect™, press the Phone button .
- To end a call, press the Phone button .

Mute (Or Unmute) Microphone During Call

- During a call, press the Voice Command button  VR .
- (After the BEEP), say “mute” (or “mute off”).

Transfer Ongoing Call Between Handset And Vehicle

- During a call, press the Voice Command button  VR .
- (After the BEEP), say “transfer call”.

Changing The Volume

- Start a dialogue by pressing the Phone button , then adjust the volume during a normal call.



- Use the radio ON/OFF VOLUME rotary knob to adjust the volume to a comfortable level while the Uconnect™ system is speaking. Please note the volume setting for Uconnect™ is different than the audio system.

NOTE: To access the tutorial, press the Uconnect™ hard-key. After the BEEP, say “tutorial”. Press any hard-key/button or touch the display (Touch-Screen radio) to cancel the tutorial.

WARNING!

- Any voice commanded system should be used only in safe driving conditions following local laws and phone use. All attention should be kept on the roadway ahead. Failure to do so may result in a collision causing you and others to be severely injured or killed.
- In an emergency, to use Uconnect™ Phone, your mobile phone must be:
 - turned on,
 - paired to Uconnect™ Phone,
 - and have network coverage.

Uconnect™ VOICE COMMAND

- The Uconnect™ Voice Command system allows you to control your AM, FM radio, satellite radio, disc player, HDD, Uconnect™ Phone, a memo recorder, and supported portable media devices.
- When you press the Voice Command button  VR located on the radio faceplate or steering wheel, you will hear a beep. The beep is your signal to give a command. If you do not say a command within a few seconds, the system will present you with a list of options. If you ever wish to interrupt the system while it lists options, press the Voice Command button  VR, listen for the BEEP, and say your command.

Voice Command for Text Messaging

- If equipped with Uconnect™ Voice Command, your Media Center 430N radio may be able to play incoming SMS messages through the vehicle sound system.
- It also allows you to respond by selecting from various pre-defined phrases.
- Not all phones are compatible with this feature. Refer to the phone compatibility list at www.ramtrucks.com/uconnect. Connected mobile phones must be bluetooth-compatible, and paired with your radio.

Changing The Volume

- Start a dialogue by pressing the Voice Command button  VR, then say a command (for example, “tutorial”).
- Use the radio ON/OFF VOLUME rotary knob to adjust the volume to a comfortable level while the Voice Command system is speaking. The volume setting for Voice Command is different than the audio system.

ELECTRONICS

- For vehicles equipped with Video Entertainment System (VES)[™], refer to the Uconnect[™] Voice Command section of the Uconnect[™] User's Manual on the DVD for further details.
- For vehicles not equipped with VES[™], refer to your vehicle Owner's Manual on the DVD for Uconnect[™] Voice Command information.

NOTE: To access the tutorial, press the Voice Command button  VR . After the BEEP, say "tutorial". Press any hard-key/button or touch the display (Touch-Screen radio) to cancel the tutorial.

WARNING!

Any voice commanded system should be used only in safe driving conditions following local laws and phone use. All attention should be kept on the roadway ahead. Failure to do so may result in a collision causing you and others to be severely injured or killed.

PROGRAMMABLE FEATURES

- The following features may be programmed using the Key Fob transmitter or the ignition switch and driver's door lock switch.

NOTE: Pressing the LOCK button while you are inside the vehicle will activate the Vehicle Security Alarm. Opening a door with the Vehicle Security Alarm activated will cause the alarm to sound. Press the UNLOCK button to deactivate the Vehicle Security Alarm.

Unlock On First Press

- To unlock either the driver's side, or all doors, on the first press of the UNLOCK button:
 - Press and hold the LOCK button for at least 4 seconds, but no longer than 10 seconds. Then, press and hold the UNLOCK button while still holding the LOCK button.
 - Release both buttons at the same time.

Auto Unlock Doors On Exit

- To have all of the vehicle doors unlock when any door is opened:
 - Enter your vehicle and close all the doors.
 - Fasten your seatbelt.
 - Within 15 seconds, cycle the ignition switch between LOCK and ON and then back to LOCK four times, ending up in the LOCK position (do not start the engine).
 - Press the power door UNLOCK switch to unlock the doors. A single chime will indicate that programming is complete.

Auto Door Lock

- To have the doors lock automatically when the vehicle's speed exceeds 15 mph (24 km/h):
 - Enter your vehicle and close all the doors.
 - Fasten your seatbelt.
 - Within 10 seconds, cycle the ignition switch between LOCK and ON and then back to LOCK four times, ending up in the LOCK position (do not start the engine).
 - Press the power door LOCK switch to lock the doors. A single chime will indicate that programming is complete.

Sound Horn With Lock

- To turn the horn chirp on or off when the doors are locked:
 - Press the LOCK button for at least 4 seconds, but no longer than 6 seconds. Then, press the PANIC button while still holding the LOCK button. A single chime will sound to indicate that this feature has changed.
 - Release both buttons at the same time.

Flashing Lights With Lock

- The turn signal lights flashing when the doors are locked or unlocked feature can be turned on or off. To turn this feature on or off:
 - Press and hold the UNLOCK button for at least 4 seconds, but no longer than 6 seconds. Then, press and hold the LOCK button while still holding the UNLOCK button. A single chime will sound to indicate that this feature has changed.
 - Release both buttons at the same time.

UNIVERSAL GARAGE DOOR OPENER (HomeLink®)



Programming HomeLink®

Begin Programming

- The HomeLink® buttons are located in the overhead console.
 - Erase all channels before you begin programming by holding the two outside buttons for up to 20 seconds until the red indicator flashes.
 - Park your vehicle outside of the garage and turn the ignition switch to the ON/RUN position.
- Place the hand-held transmitter 1 to 3 in (3 to 8 cm) from the HomeLink® buttons while keeping the indicator light in view.

ELECTRONICS

- Simultaneously, press and hold both the chosen HomeLink® button and the hand-held transmitter button until the HomeLink® indicator flash rate changes from a slow to a rapidly blinking light, then release both the HomeLink® and the hand-held transmitter buttons. This may take up to 30 seconds, or longer in rare cases.
- Press and hold the just-programmed HomeLink® button; if the indicator light stays on constantly, programming is complete and the garage door should open.

NOTE:

- Only use this transceiver with a garage door opener that has a “stop and reverse” feature as required by Federal safety standards. This includes most garage door opener models manufactured after 1982. Do not use a garage door opener without these safety features. Call toll-free 1-800-355-3515 or, on the Internet, at www.HomeLink.com for safety information or assistance.
- If you are having difficulty programming your HomeLink® and your garage door opener was manufactured after 1995, you may have a rolling code. Follow the steps below for Programming A Rolling Code System.

Programming A Rolling Code System

- At the garage door opener motor (in the garage), locate the “learn” or “programming” button. This can usually be found where the hanging antenna wire is attached to the garage door opener motor (it is NOT the button normally used to open and close the door).
- Firmly press and release the “learn” or “programming” button. The name and color of the button may vary by manufacturer. Within 30 seconds, return to the vehicle and press the programmed HomeLink® button twice (holding the button for two seconds each time). If the device is plugged in and activates, programming is complete.
- If the device does not activate, press the button a third time (for two seconds) to complete the programming.

Using HomeLink®

- To operate, simply press and release the programmed HomeLink® button and the programmed device will operate.
- Refer to your Owner’s Manual on the DVD for further details. If you have any problems programming HomeLink®, or require assistance, please call toll-free 1-800-355-3515 or, on the Internet, at www.HomeLink.com.

WARNING!

- Your motorized door or gate will open and close while you are programming the universal transceiver. Do not program the transceiver if people or pets are in the path of the door or gate.

(Continued)

WARNING! (Continued)

- Do not run your vehicle in a closed garage or confined area while programming the transceiver. Exhaust gas from your vehicle contains Carbon Monoxide (CO) which is odorless and colorless. Carbon Monoxide is poisonous when inhaled and can cause you and others to be severely injured or killed.

POWER OUTLETS

- There are two 12 Volt electrical outlets on this vehicle.
- The outlet on the front console has power available only when the ignition is in the ON/RUN position. If desired, this outlet can be converted by your authorized dealer to provide power with the ignition switch in the LOCK position.
- The second outlet in the center console is powered directly from the battery (power available at all times). Items plugged into this outlet may discharge the battery and/or prevent engine starting.

NOTE:

- Do not exceed the maximum power of 160 Watts (13 Amps) at 12 Volts. If the 160 Watt (13 Amp) power rating is exceeded, the fuse protecting the system will need to be replaced.
- Power outlets are designed for accessory plugs only. Do not insert any other object in the power outlet as this will damage the outlet and blow the fuse. Improper use of the power outlet can cause damage not covered by your new vehicle warranty.

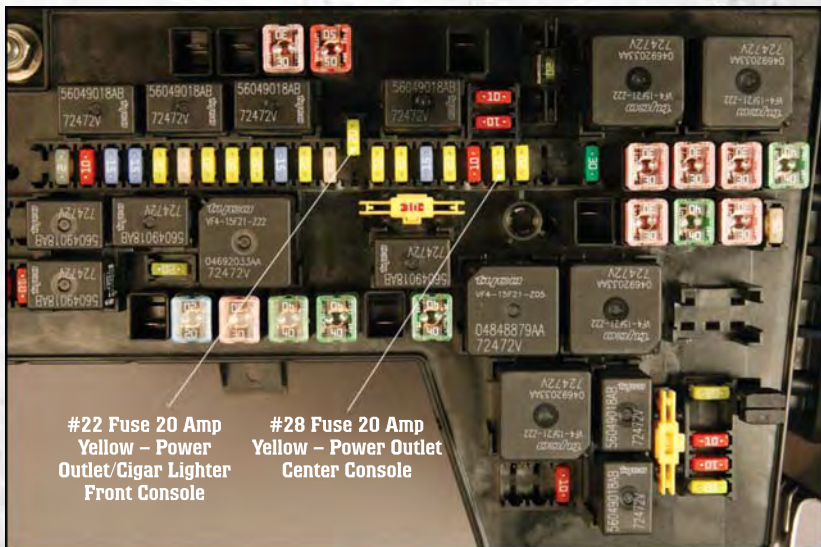

OFF-ROAD CAPABILITIES

FOUR-WHEEL DRIVE OPERATION



- This is an electric-shift transfer case and is operated by the 4WD Control Switch (Transfer Case Switch), which is located on the instrument panel.
- The transfer case provides four mode positions:
 - Two-wheel drive high range (2WD)
 - Four-wheel drive lock range (4WD LOCK)
 - Four-wheel drive low range (4WD LOW)
 - NEUTRAL (N)

- This transfer case is designed to be driven in the two-wheel drive position (2WD) for normal street and highway conditions on dry, hard-surfaced roads.
- When additional traction is required, the transfer case 4WD LOCK and 4WD LOW positions can be used to lock the front and rear driveshafts together and force the front and rear wheels to rotate at the same speed. This is accomplished by rotating the 4WD Control Switch to the desired position. The 4WD LOCK and 4WD LOW positions are designed for loose or slippery road surfaces only.
- Driving in the 4WD LOCK and 4WD LOW positions on dry hard-surfaced roads may cause increased tire wear and damage to the driveline components.

NOTE: The transfer case NEUTRAL position is selected by pressing the recessed button located on the lower left-hand corner of the 4WD Control Switch. The transfer case NEUTRAL position is to be used for recreational towing only.

NOTE: Do not attempt to make a shift while only the front or rear wheels are spinning. The NV233/243 transfer case is not equipped with a synchronizer and, therefore, the front and rear driveshaft speeds must be equal for the shift to take place. Shifting while only the front or rear wheels are spinning can cause damage to the transfer case.

WARNING!

You or others could be injured if you leave the vehicle unattended with the transfer case in the NEUTRAL position without first fully engaging the parking brake. The transfer case NEUTRAL position disengages both the front and rear driveshafts from the powertrain and will allow the vehicle to move regardless of the transmission position. The parking brake should always be applied when the driver is not in the vehicle.

REAR CRATE 'N GO® STORAGE



- The rear Crate 'n Go® storage, located under the rear seat lower cushion, consists of two removable, collapsible storage crates.
- To open the crates, lift upward on the crate handles and engage the crate end flaps.
- To remove the crate, press on the release lever, located on the ends of the base, and lift up on the crate.
- To install the crate into the base, insert the crate into the inboard slot and push down on the outboard side of the crate, then snap into place.
- To collapse the crate, push the crate end flaps inward to disengage. Push the sides inward and snap into place.

REAR CARGO AREA UTILITY RAILS

- There are four adjustable cleats in the pick-up bed that can be used to assist in securing cargo. Each cleat must be located and tightened down in one of the detents along either rail, in order to keep cargo properly secured.

TAILGATE

Tailgate Removal

- To simplify mounting a camper unit with an overhang, the tailgate can be removed quickly. Follow these steps:
 - Open the tailgate to a 45-degree angle.
 - Unclip and remove the cables from the box while maintaining a 45-degree angle.
 - Lift the tailgate off of the pivot on the passenger side by pulling upward and rearward at the same time.
 - Slide the tailgate to the passenger side while making sure clearance from the box and taillight is maintained.
- To reinstall the tailgate, do the following:
 - Slide the tailgate onto the driver's side pivot.
 - Hold the tailgate at a 45 degree angle and insert it into the passenger side pivot.
 - Clip the cables to the box.

UTILITY

Two-Position Tailgate/Upper Load Platform

- Your tailgate can be opened to the full-open or the partial-open position. The partial-open position is for loading objects longer than the length of the bed (sheets of plywood, etc.) by creating an upper load platform.

Installing Lumber

- Place lumber across the box in the indentations provided above the wheel housings and in the bulkhead dividers, to form the floor. There are indents in the sheet metal (or bed liner if equipped) on the inner side of the box in front (Crew Cab® only) and behind both wheel housings.
- Secure the tailgate in the partially-open position.
- Open the tailgate slightly.
- Snap the tailgate support cable between the cable guide and the tailgate bumper. Do this on both sides of the tailgate.
- To return the tailgate to the full-open position:
 - Lift up on tailgate.
 - Remove both cables from between the cable guides and the tailgate bumpers, and lower the tailgate.

CAUTION!

- Care should always be exercised when operating a vehicle with cargo. Vehicle speeds may need to be reduced. Severe turns or rough roads may cause shifting or bouncing of the cargo that may result in vehicle damage.

(Continued)

CAUTION! (Continued)

- Ensure the load is securely tied down and is properly identified according to local laws if it extends beyond the tail lights.
- Loading should not exceed 400 lbs (181 kg) of material suspended above the wheelhouse and partially open tailgate or vehicle damage may result.

TRAILER TOWING WEIGHTS (MAXIMUM TRAILER WEIGHT RATINGS)

NOTE: For trailer towing information (maximum trailer weight ratings) refer to the following website addresses:

- [http:// www.ramtrucks.com/towing](http://www.ramtrucks.com/towing)
- [http:// www.ramtruck.ca](http://www.ramtruck.ca) (Canada)

RECREATIONAL TOWING (BEHIND MOTORHOME, ETC.)

Two-Wheel Drive Models

- Recreational towing of two-wheel drive models is not allowable. Towing the vehicle with the transmission in NEUTRAL can cause severe transmission damage. Removal of the driveshaft for towing is not recommended, since this would allow fluid to drain from the transmission.

Four-Wheel Drive Models

Recreational Towing Procedure

- Use the following procedure to prepare your vehicle for recreational towing.
 - Bring the vehicle to a complete stop, shut the engine OFF and turn the Key Fob to the ON/RUN position (do not start the engine).
 - Press the brake pedal and shift the automatic transmission into NEUTRAL, or press the clutch pedal to the floor on a manual transmission.
 - Using a ballpoint pen or similar object, press the transfer case NEUTRAL button for four seconds.
 - After the shift is completed and the NEUTRAL light comes on, release the NEUTRAL button.
 - Start the engine and shift the automatic transmission into REVERSE.
 - Release the brake pedal for five seconds and ensure that there is no vehicle movement.
 - Repeat the previous step with the transmission in DRIVE.
 - Shut the engine OFF, and place the Key Fob in the unlocked OFF position.
 - Shift automatic transmissions into PARK. Shift manual transmissions into fourth gear.
 - Attach the vehicle to the tow vehicle with a tow bar and disconnect the negative battery cable.
 - Refer to your Owner's Manual on the DVD for further details.

NOTE:

- The first two steps are requirements that must be met prior to pressing the NEUTRAL button, and must continue to be met until the four seconds elapse and the shift has been completed. If any of these requirements (with the exception of Key Fob ON) are not met prior to pressing the NEUTRAL button or are no longer met during the four second timer, then the NEUTRAL indicator light will flash continuously until all requirements are met or until the NEUTRAL button is released.
- The Key Fob must be ON for a shift to take place and for the position indicator lights to be operable. If the Key Fob is not ON, the shift will not take place and no position indicator lights will be on or flashing.
- A flashing NEUTRAL position indicator light indicates that shift requirements have not been met.

CAUTION!

- Internal damage to the transfer case will occur if a front or rear wheel lift is used when recreational towing.
- The transfer case must be shifted into NEUTRAL for recreational towing. The NEUTRAL button is located on the lower left hand corner of the 4WD Control Switch. Shifts into and out of transfer case NEUTRAL can take place with the selector switch in any mode position.
- Automatic transmissions must be placed in PARK position for recreational towing.

(Continued)

CAUTION! *(Continued)*

- Manual transmissions must be placed in gear (for example, fourth gear) for recreational towing. Failure to follow these procedures can cause severe transmission and/or transfer case damage.
- It is necessary to follow these steps to be certain that the transfer case is fully in **NEUTRAL** before recreational towing to prevent damage to internal parts.

BRAKE/TRANSMISSION INTERLOCK SYSTEM

- This system prevents you from moving the shift lever out of **PARK** and into any gear unless the brake pedal is pressed.
- This system is active only when the ignition switch is in the **ON/RUN** position.

WHAT TO DO IN EMERGENCIES

24-HOUR TOWING ASSISTANCE

- Dial toll-free 1-800-521-2779 or 1-800-363-4869 for Canadian residents.
- Provide your name, vehicle identification number and license plate number.
- Provide your location, including telephone number, from which you are calling.
- Briefly describe the nature of the problem and answer a few simple questions.
- You will be given the name of the service provider and an estimated time of arrival. If you feel you are in an “unsafe situation”, please let us know. With your consent, we will contact local police or safety authorities.

INSTRUMENT CLUSTER WARNING LIGHTS

(!) - Tire Pressure Monitoring System (TPMS) Light

- Each tire, including the spare (if provided), should be checked monthly, when cold and inflated to the inflation pressure recommended by the vehicle manufacturer on the vehicle placard or tire inflation pressure label. (If your vehicle has tires of a different size than the size indicated on the vehicle placard or tire inflation pressure label, you should determine the proper tire inflation pressure for those tires.)
- As an added safety feature, your vehicle has been equipped with a Tire Pressure Monitoring System (TPMS) that illuminates a low tire pressure telltale when one or more of your tires is significantly under-inflated. Accordingly, when the low tire pressure telltale illuminates, you should stop and check your tires as soon as possible, and inflate them to the proper pressure. Driving on a significantly under-inflated tire causes the tire to overheat and can lead to tire failure. Under-inflation also reduces fuel efficiency and tire tread life, and may affect the vehicle's handling and stopping ability.
- **IF THE LIGHT STARTS FLASHING INDICATING A LOW TIRE PRESSURE, ADJUST THE AIR PRESSURE IN THE LOW TIRE TO THE AIR PRESSURE SHOWN ON THE VEHICLE PLACARD OR TIRE INFLATION PRESSURE LABEL LOCATED ON THE DRIVER'S DOOR. NOTE: AFTER INFLATION, THE VEHICLE MAY NEED TO BE DRIVEN FOR 20 MINUTES BEFORE THE FLASHING LIGHT WILL TURN OFF.**
- Please note that the TPMS is not a substitute for proper tire maintenance, and it is the driver's responsibility to maintain correct tire pressure, even if under-inflation has not reached the level to trigger illumination of the TPMS low tire pressure telltale.
- Your vehicle has also been equipped with a TPMS malfunction indicator to indicate when the system is not operating properly. The TPMS malfunction indicator is combined with the low tire pressure telltale. When the system detects a malfunction, the telltale will flash for approximately one minute and then remain continuously illuminated. This sequence will continue each time the vehicle is restarted as long as the malfunction exists.

WHAT TO DO IN EMERGENCIES

- When the malfunction indicator is illuminated, the system may not be able to detect or signal low tire pressure as intended. TPMS malfunctions may occur for a variety of reasons, including the installation of replacement or alternate tires or wheels on the vehicle that prevent the TPMS from functioning properly. Always check the TPMS malfunction telltale after replacing one or more tires or wheels on your vehicle, to ensure that the replacement or alternate tires and wheels allow the TPMS to continue to function properly.

CAUTION!

The TPMS has been optimized for the original equipment tires and wheels. TPMS pressures and warning have been established for the tire size equipped on your vehicle. Undesirable system operation or sensor damage may result when using replacement equipment that is not of the same size, type, and/or style. Aftermarket wheels can cause sensor damage. Do not use tire sealant from a can, or balance beads if your vehicle is equipped with a TPMS, as damage to the sensors may result.

- Engine Temperature Warning Light

- This light warns of an overheated engine condition.
- If the light turns on and a warning chime sounds while driving, safely pull over and stop the vehicle. If the A/C system is on, turn it off. Also, shift the transmission into NEUTRAL and idle the vehicle. If the temperature reading does not return to normal, turn the engine off immediately.
- We recommend that you do not operate the vehicle or engine damage will occur. Have the vehicle serviced immediately.

WARNING!

A hot engine cooling system is dangerous. You or others could be badly burned by steam or boiling coolant. You may want to call an authorized service center for service if your vehicle overheats.

BRAKE - Brake Warning Light

- The Brake Warning light illuminates when there is either a system malfunction or the parking brake is applied. If the light is on and the parking brake is not applied, it indicates a possible brake hydraulic malfunction, brake booster problem or an Anti-Lock Brake System problem.
- We recommend you drive to the nearest service center and have the vehicle serviced immediately.

WHAT TO DO IN EMERGENCIES

WARNING!

Driving a vehicle with the red brake light on is dangerous. Part of the brake system may have failed. It will take longer to stop the vehicle. You could have a collision. Have the vehicle checked immediately.

- Malfunction Indicator Light (MIL)

- Certain conditions, such as a loose or missing gas cap, poor fuel quality, etc., may illuminate the MIL after engine start. The vehicle should be serviced if the light stays on through several typical driving cycles. In most situations, the vehicle will drive normally and not require towing.
- If the MIL flashes when the engine is running, serious conditions may exist that could lead to immediate loss of power or severe catalytic converter damage. We recommend you do not operate the vehicle. Have the vehicle serviced immediately.

- Charging System Light

- This light shows the status of the electrical charging system. If the charging system light remains on, it means that the vehicle is experiencing a problem with the charging system.
- We recommend you do not continue driving if the charging system light is on. Have the vehicle serviced immediately.

- Oil Pressure Warning Light

- This light indicates low engine oil pressure. If the light turns on while driving, stop the vehicle and shut off the engine as soon as possible. A chime will sound for four minutes when this light turns on.
- We recommend you do not operate the vehicle or engine damage will occur. Have the vehicle serviced immediately.

- Anti-Lock Brake (ABS) Light

- This light monitors the Anti-Lock Brake System (ABS).
- If the light is not on during starting, stays on, or turns on while driving, we recommend you drive to the nearest service center and have the vehicle serviced immediately.

- Electronic Throttle Control (ETC) Light

- This light informs you of a problem with the Electronic Throttle Control (ETC) system.
- If a problem is detected, the light will come on while the engine is running. Cycle the ignition when the vehicle has completely stopped and the shift lever is placed in the PARK position; the light should turn off.

WHAT TO DO IN EMERGENCIES

- If the light remains lit with the engine running, your vehicle will usually be drivable; however, see an authorized service center immediately. If the light is flashing when the engine is running, immediate service is required and you may experience reduced performance, an elevated/rough idle or engine stall and your vehicle may require towing.

- Airbag Warning Light

- If the light is not on during starting, stays on, or turns on while driving, have the vehicle serviced by an authorized service center immediately.

- SVC (Service) 4WD Indicator Light

- If the light stays on or comes on during driving, it means that the 4WD system is not functioning properly and that service is required. We recommend you do not operate the vehicle. Have the vehicle serviced immediately.

- Transmission Temperature Warning Light

- This light indicates that there is excessive transmission fluid temperature that might occur with severe usage such as trailer towing. If this light turns on, stop the vehicle and run the engine at idle, with the transmission in NEUTRAL, until the light turns off. Once the light turns off, you may continue to drive normally.

Fuel Cap/Loose Gas Cap Message

- If a “gas cap” message (shown as gASCAP) appears, tighten the gas cap until a “clicking” sound is heard.
- Press the odometer reset button to turn the message off.
- If the message continues to appear for more than three days after tightening the gas cap, see your authorized service center.

Oil Change Indicator Message

- If an “oil change” message (shown as CHAnGE OIL) appears and a single chime sounds, it is time for your next required oil change.

Resetting The Light After Servicing

- Turn the ignition switch to the ON/RUN position (do not start engine).
- Fully depress the accelerator pedal three times within 10 seconds.
- Turn the ignition switch to the OFF/LOCK position.

IF YOUR ENGINE OVERHEATS

- In any of the following situations, you can reduce the potential for overheating by taking the appropriate action.
 - On the highways — slow down.
 - In city traffic — while stopped, shift transmission into NEUTRAL, but do not increase engine idle speed.

WHAT TO DO IN EMERGENCIES

NOTE: There are steps that you can take to slow down an impending overheating condition:

- If your air conditioner (A/C) is on, turn it off. The A/C system adds heat to the engine cooling system and turning the A/C off can help remove this heat.
- You can also turn the Temperature Control to maximum heat, the Mode Control to floor and the Fan Control to high. This allows the heater core to act as a supplement to the radiator and aids in removing heat from the engine cooling system.
- If the temperature reading does not return to normal, turn the engine off immediately.
- We recommend that you do not operate the vehicle or engine damage will occur. Have the vehicle serviced immediately.

CAUTION!

Driving with a hot cooling system could damage your vehicle. If the temperature gauge reads HOT (H), pull over and stop the vehicle. Idle the vehicle with the air conditioner turned off until the pointer drops back into the normal range. If the pointer remains on HOT (H), and you hear continuous chimes, turn the engine off immediately and call for service.

WARNING!

You or others can be badly burned by hot engine coolant (antifreeze) or steam from your radiator. If you see or hear steam coming from under the hood, do not open the hood until the radiator has had time to cool. Never try to open a cooling system pressure cap when the radiator or coolant bottle is hot.

WHAT TO DO IN EMERGENCIES

JACKING AND TIRE CHANGING

Jack Location

Extended Cab



- The scissor jack and tire changing tools are stowed in a compartment under the rear passenger seat.

Crew Cab®

- The scissor jack and tire changing tools are accessed by lifting up the rear passenger seat.
- The jack is secured in place by turning the jack screw until the jack is secured into place.
- A finger-operated helper tool is provided to assist removal and stowage of the jack. This tool must be removed to operate the jack for changing the spare tire.

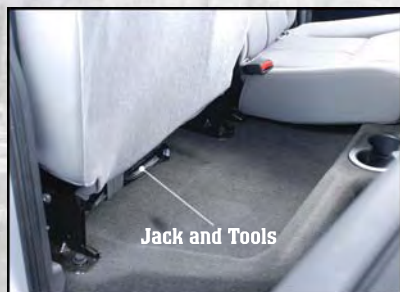

Spare Tire Stowage

- To remove the spare tire, remove the jack-handle components from the storage compartment and assemble them.
- Attach the wheel wrench to the jack extension tube and insert the tube through the access hole in the rear bumper and into the winch mechanism tube.
- Rotate the wheel wrench handle counterclockwise until the spare tire is on the ground with enough cable slack to allow you to pull it out from under the vehicle.
- When the spare is clear, tilt the retainer at the end of the cable and pull it through the center of the wheel.

WHAT TO DO IN EMERGENCIES

Preparations For Jacking

- Park on a firm, level surface. Avoid ice or slippery areas.
- Set the parking brake and shift the automatic transmission into PARK. On Four-Wheel Drive vehicles, shift the transfer case to the 4L position.
- Turn the ignition to LOCK and turn on the Hazard Warning flasher.

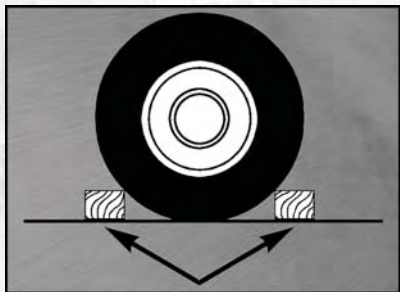

- Block both the front and rear of the wheel diagonally opposite of the jacking position. For example, if changing the right front tire, block the left rear wheel.

NOTE: Passengers should not remain in the vehicle when the vehicle is being jacked.

Jacking And Tire Changing Instructions

- Remove the spare tire, jack and tools from their stored location.
- Loosen (but do not remove) the wheel lug nuts by turning them counterclockwise one turn while the wheel is still on the ground.
- Assemble the jack and jacking tools. Connect the jack handle driver to the extension, then to the lug wrench.

WHAT TO DO IN EMERGENCIES

- Place the jack:
- For front wheels, place the jack under the frame rail behind the wheel. Locate the jack as far forward as possible on the straight part of the frame prior to inboard transition.

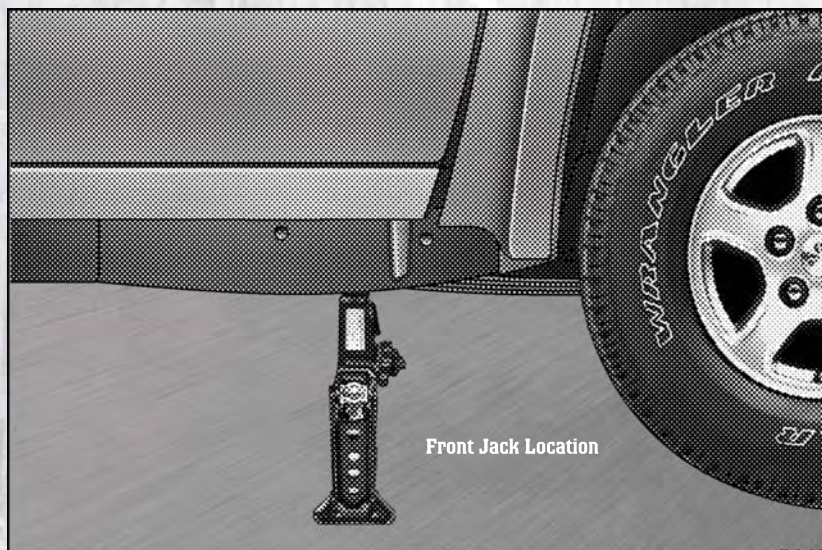

WHAT TO DO IN EMERGENCIES

- For rear wheels, place the jack under the axle between the u-bolts attaching the spring to the axle.

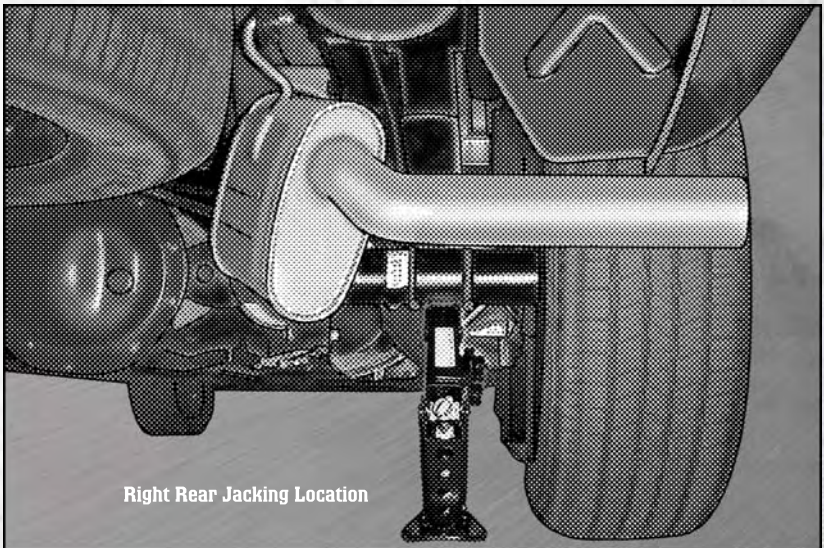
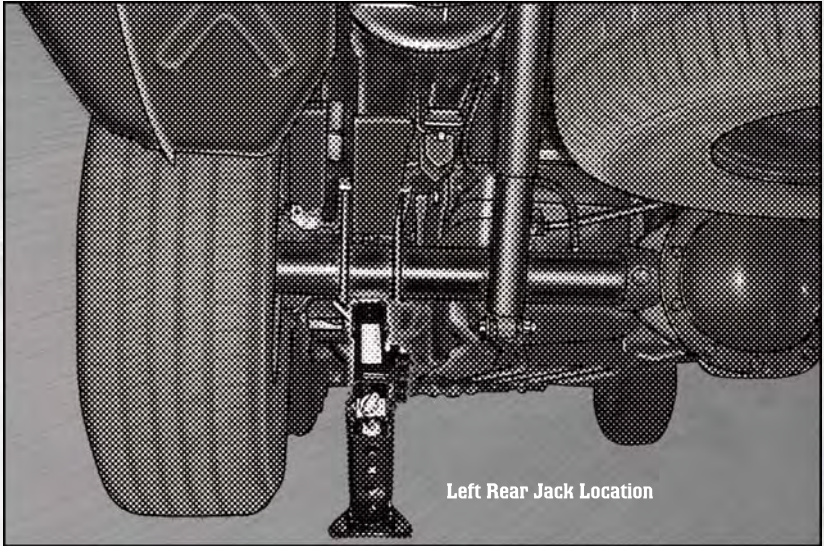

- Turn the jack screw clockwise to firmly engage the jack saddle with the lift area.

WHAT TO DO IN EMERGENCIES

- Raise the vehicle by turning the jack screw clockwise. Raise the vehicle only until the tire just clears the surface and enough clearance is obtained to install the spare tire.
- Remove the lug nuts and wheel.
- Position the spare wheel/tire on the vehicle and install the lug nuts with the cone-shaped end toward the wheel. Lightly tighten the lug nuts clockwise. To avoid the risk of forcing the vehicle off the jack, do not tighten the nuts fully until the vehicle has been lowered.
- Lower the vehicle by turning the jack screw counterclockwise, and remove the jack and wheel blocks.
- Finish tightening the lug nuts. Push down on the wrench while tightening for increased leverage. Alternate nuts until each one has been tightened twice. The correct wheel nut tightness is 120 to 160 ft lbs (163 to 217 N·m). If in doubt about the correct tightness, have them checked with a torque wrench by your authorized dealer or at a service station.
- Secure the jack and tools in their proper locations.
- For convenience in checking the spare tire inflation, stow with the valve stem toward the rear of the vehicle. Continue winching up the tire until you hear the winch click three times.

NOTE: To Stow the Flat or Spare: The wheel retainer does not fit through the center of the aluminum wheel. The tire must be stored in a safe manner in the bed of the truck.

WARNING!

- Do not attempt to change a tire on the side of the vehicle close to moving traffic. Pull far enough off the road to avoid the danger of being hit when operating the jack or changing the wheel.
- Getting under a jacked-up vehicle is dangerous. The vehicle could slip off the jack and fall on you. You could be crushed. Never get any part of your body under a vehicle that is on a jack. If you need to get under a raised vehicle, take it to a service center where it can be raised on a lift.
- The jack is designed to use as a tool for changing tires only. The jack should not be used to lift the vehicle for service purposes. The vehicle should be jacked on a firm, level surface only. Avoid ice or slippery areas.
- If it is necessary to retrieve the spare tire from under the vehicle on the side of the vehicle close to moving traffic, pull far enough off the road to avoid the danger of being hit.
- Do not attempt to change a tire on the side of the vehicle close to moving traffic. Pull far enough off the road to avoid being hit when operating the jack or changing the wheel.
- Carefully follow these tire changing procedures to help prevent personal injury or damage to your vehicle: Always park on a firm, level surface as far from the edge of the roadway as possible before raising the vehicle.

(Continued)

WHAT TO DO IN EMERGENCIES

WARNING! *(Continued)*

- Raising the vehicle higher than necessary can make the vehicle less stable and could cause it to slip off the jack and hurt someone near it. Raise the vehicle only enough to remove the tire.
- A loose tire or jack, thrown forward in a collision or hard stop, could endanger the occupants of the vehicle. Always stow the jack parts and the spare tire in the places provided.

JUMP-STARTING



- If your vehicle has a discharged battery it can be jump-started using a set of jumper cables and a battery in another vehicle or by using a portable battery booster pack.
- Jump-starting can be dangerous if done improperly so please follow the procedures in this section carefully.

NOTE: When using a portable battery booster pack follow the manufacturer's operating instructions and precautions.

Preparations for Jump-Start

- The battery in your vehicle is located in the front of the engine compartment, behind the left headlight assembly.
- Set the parking brake, shift the automatic transmission into PARK and turn the ignition to LOCK.
- Turn off the heater, radio, and all unnecessary electrical accessories.

WHAT TO DO IN EMERGENCIES

- If using another vehicle to jump-start the battery, park the vehicle within the jumper cables reach, set the parking brake and make sure the ignition is OFF.

Jump-Starting Procedure

- Connect the positive (+) end of the jumper cable to the positive (+) post of the discharged vehicle.
- Connect the opposite end of the positive (+) jumper cable to the positive (+) post of the booster battery.
- Connect the negative end (-) of the jumper cable to the negative (-) post of the booster battery.
- Connect the opposite end of the negative (-) jumper cable to a good engine ground (exposed metal part of the discharged vehicle's engine) away from the battery and the fuel injection system.
- Start the engine in the vehicle that has the booster battery, let the engine idle a few minutes, and then start the engine in the vehicle with the discharged battery.

Once the engine is started, remove the jumper cables in the reverse sequence:

- Disconnect the negative (-) jumper cable from the engine ground of the vehicle with the discharged battery.
- Disconnect the negative end (-) of the jumper cable from the negative (-) post of the booster battery.
- Disconnect the opposite end of the positive (+) jumper cable from the positive (+) post of the booster battery.
- Disconnect the positive (+) end of the jumper cable from the positive (+) post of the discharged vehicle.
- If frequent jump-starting is required to start your vehicle you should have the battery and charging system inspected at your authorized dealer.

CAUTION!

- Accessories that can be plugged into the vehicle power outlets draw power from the vehicle's battery, even when not in use (i.e., cellular phones, etc.). Eventually, if plugged in long enough, the vehicle's battery will discharge sufficiently to degrade battery life and/or prevent the engine from starting.
- Do not use a portable battery booster pack or any other booster source with a system voltage greater than 12 Volts or damage to the battery, starter motor, alternator or electrical system may occur.
- Failure to follow these procedures could result in damage to the charging system of the booster vehicle or the discharged vehicle.

WHAT TO DO IN EMERGENCIES

WARNING!

- When temperatures are below the freezing point, electrolyte in a discharged battery may freeze. Do not attempt jump-starting because the battery could rupture or explode and cause personal injury. Battery temperature must be brought above freezing point before attempting a jump-start.
- Take care to avoid the radiator cooling fan whenever the hood is raised. It can start anytime the ignition switch is on. You can be injured by moving fan blades.
- Remove any metal jewelry, such as watch bands or bracelets, that might make an inadvertent electrical contact. You could be severely injured.
- Batteries contain sulfuric acid that can burn your skin or eyes and generate hydrogen gas which is flammable and explosive. Keep open flames or sparks away from the battery.
- Do not allow vehicles to touch each other as this could establish a ground connection and personal injury could result.
- Failure to follow this procedure could result in personal injury or property damage due to battery explosion.
- Do not connect the cable to the negative post (-) of the discharged battery. The resulting electrical spark could cause the battery to explode and could result in personal injury.

EMERGENCY TOW HOOKS

- If your vehicle is equipped with tow hooks, they are mounted in the front and the rear.

NOTE: For off-road recovery, it is recommended to use both of the front tow hooks to minimize the risk of damage to the vehicle.

CAUTION!

Tow hooks are for emergency use only, to rescue a vehicle stranded off-road. Do not use tow hooks for tow truck hookup or highway towing. You could damage your vehicle. Tow straps are recommended when towing the vehicle; chains may cause vehicle damage.

WARNING!

- Chains are not recommended for freeing a stuck vehicle. Chains may break, causing serious injury or death.
- Stand clear of vehicles when pulling with tow hooks. Tow straps may become disengaged, causing serious injury.

WHAT TO DO IN EMERGENCIES

TOWING A DISABLED VEHICLE

Model	Flat Towing (all four wheels on the ground)	Flatbed Towing (all four wheels suspended OFF the ground)	Front Wheels Raised, Rear Wheels on the Ground	Rear Wheels Raised, Front Wheels on the Ground
Two-Wheel Drive	NOT Permitted	Recommended Method	Shift lever must be In NEUTRAL, the speed less than 30 mph (48 km/h) and the distance traveled less than 15 mi (24 km).	May be used
Four-Wheel Drive	NOT Permitted	Recommended Method	NOT Permitted without a towing dolly	NOT Permitted without a towing dolly

WHAT TO DO IN EMERGENCIES

FREEING A STUCK VEHICLE

- If your vehicle becomes stuck in mud, sand or snow, it can often be moved by a rocking motion. Turn your steering wheel right and left to clear the area around the front wheels. Then move the shift lever back and forth between REVERSE and DRIVE. Using minimal accelerator pedal pressure to maintain the rocking motion, without spinning the wheels, is most effective.
- Allow the engine to idle with the shift lever in NEUTRAL for at least one minute after every five rocking-motion cycles. This will minimize overheating and reduce the risk of transmission failure during prolonged efforts to free a stuck vehicle.

CAUTION!

- When “rocking” a stuck vehicle by moving between REVERSE and DRIVE, do not spin the wheels faster than 15 mph (24 km/h), or drivetrain damage may result.
- Revving the engine or spinning the wheels too fast may lead to transmission overheating and failure. It can also damage the tires. Do not spin the wheels above 30 mph (48 km/h) while in gear (no transmission shifting occurring).

WARNING!

- Fast spinning tires can be dangerous. Forces generated by excessive wheel speeds may cause tire damage or failure. A tire could explode and injure someone. Do not spin your vehicle's wheels faster than 30 mph (48 km/h) when you are stuck. Do not let anyone near a spinning wheel, no matter what the speed.
- Chains are not recommended for freeing a stuck vehicle. Chains may break, causing serious injury or death.
- Stand clear of vehicles when pulling with tow hooks. Tow straps and chains may break, causing serious injury.

WHAT TO DO IN EMERGENCIES

EVENT DATA RECORDER (EDR)

- This vehicle is equipped with an event data recorder (EDR). The main purpose of an EDR is to record, in certain crash or near crash-like situations, such as an air bag deployment or hitting a road obstacle, data that will assist in understanding how a vehicle's systems performed. The EDR is designed to record data related to vehicle dynamics and safety systems for a short period of time, typically 30 seconds or less. The EDR in this vehicle is designed to record such data as:
 - How various systems in your vehicle were operating;
 - How far (if at all) the driver was depressing the accelerator and/or brake pedal; and,
 - How fast the vehicle was traveling.
- These data can help provide a better understanding of the circumstances in which crashes and injuries occur.

NOTE: EDR data are recorded by your vehicle only if a non-trivial crash situation occurs; no data are recorded by the EDR under normal driving conditions and no personal data (e.g. name, gender, age, and crash location) are recorded. However, other parties, such as law enforcement, could combine the EDR data with the type of personally identifying data routinely acquired during a crash investigation.

- To read data recorded by an EDR, special equipment is required, and access to the vehicle or the EDR is needed. In addition to the vehicle manufacturer, other parties such as law enforcement, that have the special equipment, can read the information if they have access to the vehicle or the EDR.

MAINTAINING YOUR VEHICLE

OPENING THE HOOD



Hood Release

- Pull the hood release lever located below the steering wheel at the base of the instrument panel.
- Reach into the opening beneath the center of the hood and move the safety latch lever while lifting the hood at the same time.

WARNING!

Be sure the hood is fully latched before driving your vehicle. If the hood is not fully latched, it could open when the vehicle is in motion and block your vision. Failure to follow this warning could result in serious injury or death.

MAINTAINING YOUR VEHICLE

ENGINE COMPARTMENT

3.7L Engine

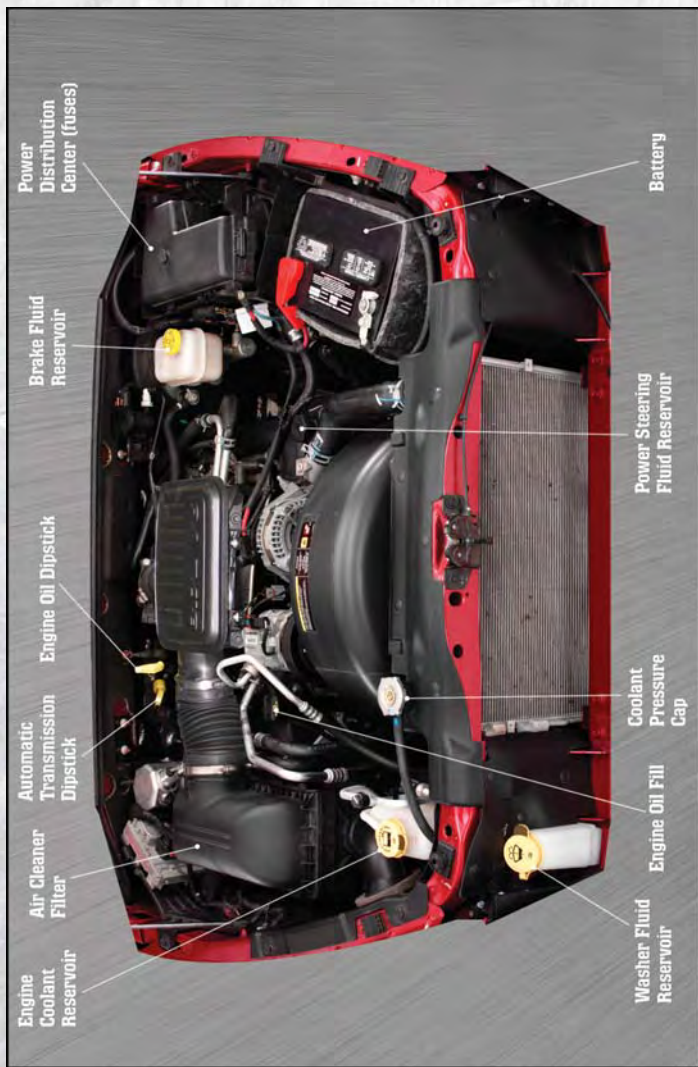

MAINTAINING YOUR VEHICLE

4.7L Engine

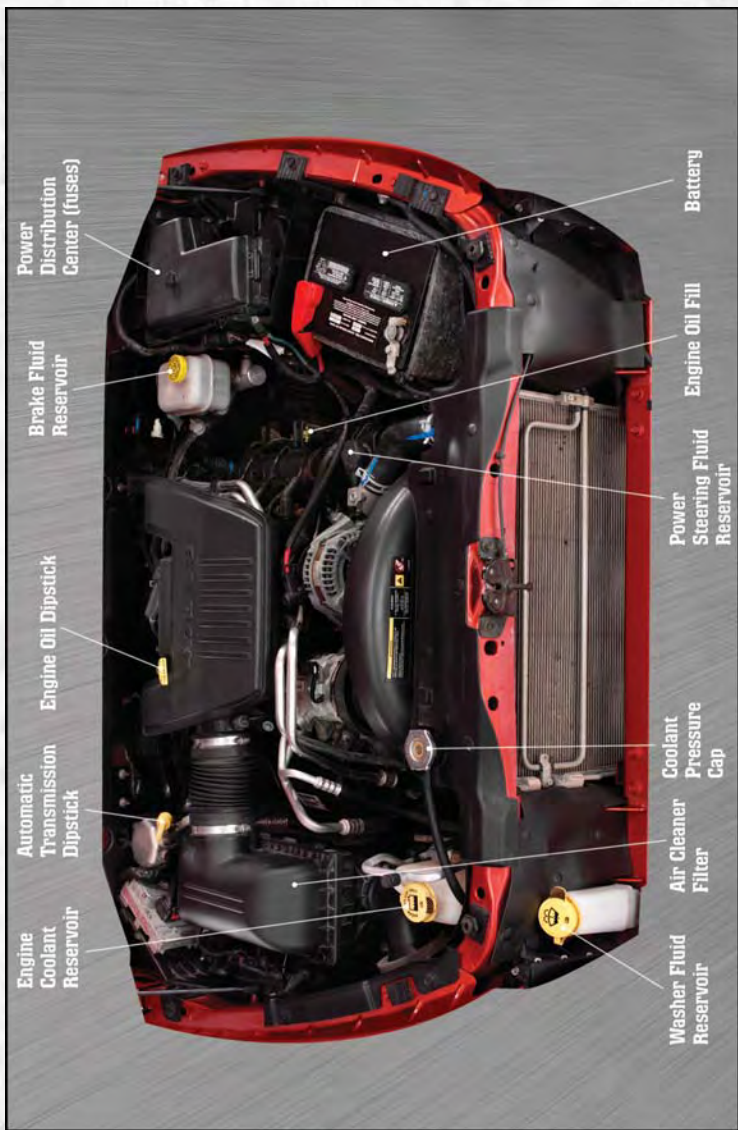

MAINTAINING YOUR VEHICLE

FLUIDS AND CAPACITIES

Component	Fluid, Lubricant, or Genuine Part	Capacities
Engine Coolant 3.7L, 4.7L	MOPAR® Antifreeze/Coolant Five Year/100,000 Mile Formula HOAT (Hybrid Organic Additive Technology) or equivalent.	13.3 Quarts (12.5 Liters) Includes heater and coolant recovery bottle filled to MAX level.
Engine Oil with Filter 3.7L, 4.7L	API certified 5W-20 engine oil, meeting the requirements of Chrysler Material Standard MS-6395. Refer to your oil filler cap for correct SAE grade.	3.7L 5 Quarts (4.7 Liters) 4.7L 6 Quarts (5.7 Liters)
Fuel Selection 3.7L, 4.7L	87 Octane	22 Gallons (83 Liters)
Engine Oil Filter 3.7L, 4.7L	MOPAR® Engine Oil Filter or equivalent.	—
Spark Plug 3.7L	ZFR6F-11G (Gap 0.043 in [1.09 mm])	—
Spark Plug 4.7L	Upper Bank — FR8TE2 (Gap 0.039 in [0.99 mm]) Lower Bank — FR8T1332 (Gap 0.051 in [1.30 mm]).	—
Automatic Transmission	MOPAR® ATF+4® Automatic Transmission Fluid or equivalent licensed ATF+4® product.	—
Transfer Case	MOPAR® ATF+4® Automatic Transmission Fluid or equivalent licensed ATF+4® product.	—
Front Axle	SAE 75W-90 Multi-Purpose Type, GL-5 Gear Lubricant MS-9763 or equivalent.	—
Rear Axle	SAE 75W-140 Synthetic Gear Lubricant MS-8985. Limited-slip rear axles require MOPAR® Limited-Slip Additive MS-10111 or equivalent. Whenever a fluid change is made, 4 oz (118 ml) should be added to the gear lubricant.	—

MAINTAINING YOUR VEHICLE

Component	Fluid, Lubricant, or Genuine Part	Capacities
Brake Master Cylinder	MOPAR® DOT 3 and SAE J1703 should be used or equivalent. If DOT 3 is not available, then DOT 4 is acceptable. Use only recommended Brake Fluids.	—
Power Steering Reservoir	MOPAR® Power Steering Fluid +4 or MOPAR® ATF+4® Automatic Transmission Fluid or equivalent licensed ATF+4® product.	—

MAINTAINING YOUR VEHICLE

	Miles:		8,000	16,000	24,000	32,000	40,000	48,000	56,000	64,000	72,000	80,000	88,000	96,000	104,000
	Or Months:	Or Kilometers:	6	12	18	24	30	36	42	48	54	60	66	72	78
			13,000	26,000	39,000	52,000	65,000	78,000	91,000	104,000	117,000	130,000	143,000	156,000	169,000
Change the engine oil and filter.	X	X	X	X	X	X	X	X	X	X	X	X	X	X	X
Rotate the tires, rotate at the first sign of irregular wear, even if it occurs before scheduled maintenance.	X	X	X	X	X	X	X	X	X	X	X	X	X	X	X
If using your vehicle for any of the following: dusty or off-road conditions, inspect the engine air cleaner filter; replace if necessary.		X	X	X				X				X			
Inspect the brake linings; replace if necessary.		X	X	X	X	X	X	X	X	X	X	X	X	X	X
Inspect the CV joints.				X	X	X	X	X	X	X	X	X	X	X	X
Inspect the exhaust system. Perform the first inspection at 16,000 miles (26,000 km) or 12 months.		X	X	X	X	X	X	X	X	X	X	X	X	X	X
Inspect the front suspension, tie rod ends and boot seals for cracks or leaks and all parts for damage, wear, improper looseness or end play; replace if necessary.		X	X	X	X	X	X	X	X	X	X	X	X	X	X
Replace the engine air cleaner filter.						X	X	X	X	X	X	X	X	X	X
Inspect the transfer case fluid.						X	X	X	X	X	X	X	X	X	X
Inspect the front and rear axle fluid if using your vehicle for any of the following: police, taxi, off-road or frequent trailer towing.				X	X	X	X	X	X	X	X	X	X	X	X
Change the automatic transmission fluid & filter(s) if using your vehicle for any of the following: police, taxi, fleet, or frequent trailer towing.									X	X	X	X	X	X	X
Replace Ignition Cables (3.7L Engine).										X	X	X	X	X	X
Replace the spark plugs (3.7L engines).						X	X	X	X	X	X	X	X	X	X
Replace Ignition Cables (4.7L Engine).										X	X	X	X	X	X

MAINTAINING YOUR VEHICLE

Miles: Or Months: Or Kilometers:	8,000	16,000	24,000	32,000	40,000	48,000	56,000	64,000	72,000	80,000	88,000	96,000	104,000
	6	12	18	24	30	36	42	48	54	60	66	72	78
	13,000	26,000	39,000	52,000	65,000	78,000	91,000	104,000	117,000	130,000	143,000	156,000	169,000
Replace upper bank spark plugs (4.7L engine).						X						X	
Change the transfer case fluid if using your vehicle for any of the following: police, taxi, fleet, off-road, or frequent trailer towing.								X					
Flush and replace the engine coolant at 60 months or 104,000 miles (169,000 km) whichever comes first.										X			
Flush and replace the engine coolant at 104,000 miles (169,000 km) or 60 months whichever comes first.													X
Inspect and replace PCV valve if necessary.												X	

- Refer to the Owner's Manual on the DVD for the complete maintenance schedule.

MAINTAINING YOUR VEHICLE

Maintenance Record

	Odometer	Date	Signature, Authorized Service Center
8,000 Miles (13,000 km) or 6 Months			
16,000 Miles (26,000 km) or 12 Months			
24,000 Miles (39,000 km) or 18 Months			
32,000 Miles (52,000 km) or 24 Months			
40,000 Miles (65,000 km) or 30 Months			
48,000 Miles (78,000 km) or 36 Months			
56,000 Miles (91,000 km) or 42 Months			
64,000 Miles (104,000 km) or 48 Months			
72,000 Miles (117,000 km) or 54 Months			
80,000 Miles (130,000 km) or 60 Months			
88,000 Miles (143,000 km) or 66 Months			
96,000 Miles (156,000 km) or 72 Months			
104,000 Miles (169,000 km) or 78 Months			

MAINTAINING YOUR VEHICLE

FUSES

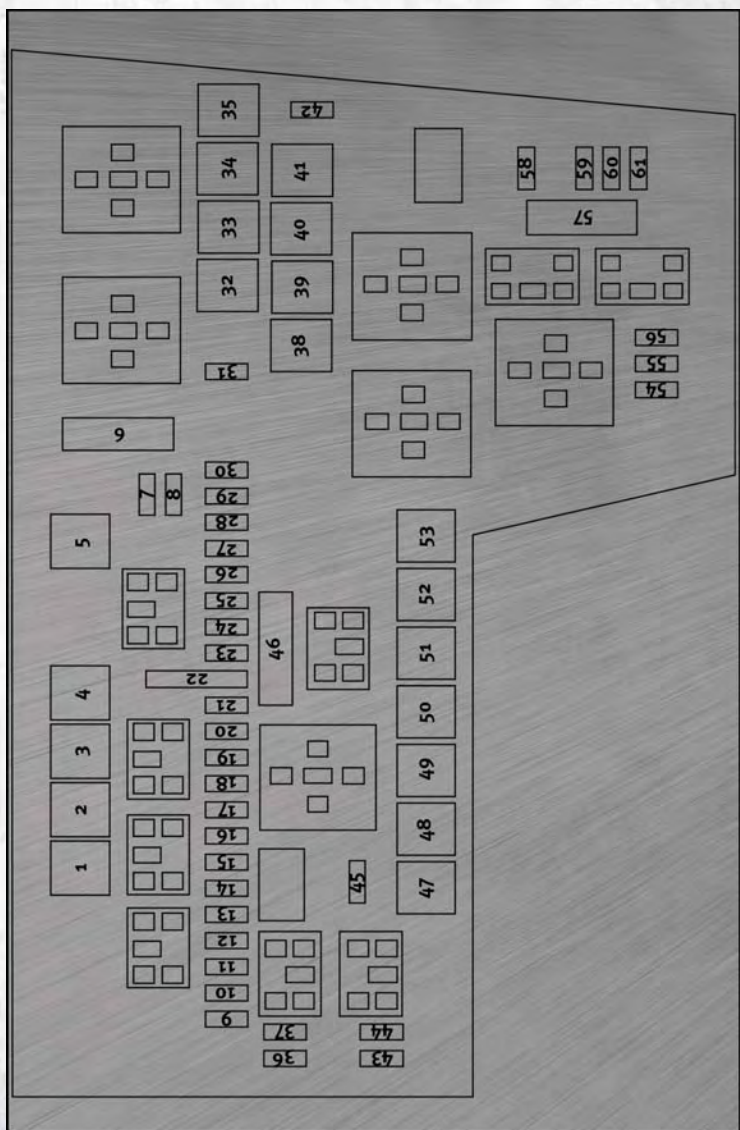

MAINTAINING YOUR VEHICLE

Power Distribution Center (fuses)

- The Power Distribution Center located on the left side of the engine compartment. This center contains cartridge fuses, mini fuses and relays.

Cavity	Cartridge Fuse	Mini-Fuse	Description
1	—	—	Spare
2	—	—	Spare
3	30 Amp Pink		Electric Brake
4	50 Amp Red		Power Seat
5	—	—	Spare
6		20 Amp Yellow	Ignition Off Draw (IOD) Cabin Compartment Node (CCN), Radio
7		10 Amp Red	Powertrain Control Module (PCM)/Fuel/RAD/AC Coils
8		10 Amp Red	Cabin Compartment Node (CCN)/Mirror/4x4
9	—	—	Spare
10		2 Amp Gray	Run/Start Ignition Switch
11		10 Amp Red	AC Clutch
12		15 Amp Blue	Trailer Tow Lt Stop/Turn
13		15 Amp Blue	Trailer Tow Rt Stop/Turn
14		20 Amp Yellow	Ignition Off Draw (IOD) #2
15		25 Amp Natural	Trans/Powertrain Control Module (PCM)
16		20 Amp Yellow	Horn
17		20 Amp Yellow	ABS Feed (Valves)
18		20 Amp Yellow	Fuel Pump
19		15 Amp Blue	Center High-Mounted Stop Light (CHMSL)
20		20 Amp Yellow	Instrument Cluster/Door Locks/Brake Transmission Shift Interlock (BTSI)
21		25 Amp Natural	Audio Amp
22		20 Amp Yellow	Power Outlet (Switchable)
23		20 Amp Yellow	Fog Lamps
24		20 Amp Yellow	Powertrain Control Module (PCM) B+
25		15 Amp Blue	Instrument Cluster Illumination
26		20 Amp Yellow	Ignition Run/Start Feed
27		10 Amp Red	Power Mirror
28		20 Amp Yellow	Power Outlet
29		20 Amp Yellow	Front Control Module (FCM) 4 (Wipers)
30	—	—	Spare

MAINTAINING YOUR VEHICLE

Cavity	Cartridge Fuse	Mini-Fuse	Description
31		30 Amp Green	Ignition Run/AC/Windows
32	30 Amp Pink		Front Control Module (FCM) 1 (Ext. Lights # 1)
33	30 Amp Pink		Auto Shut Down (ASD)
34	30 Amp Pink		Front Control Module (FCM) 2 (Ext. Light # 2)
35	40 Amp Green		HVAC Blower Motor
36	—	—	Spare
37	—	—	Spare
38	20 Amp Blue	—	Spare
39	30 Amp Pink		Starter Solenoid
40	40 Amp Green		Ignition Run Feeds
41	30 Amp Pink		Wiper Motor
42		25 Amp Natural	Front Control Module (FCM) 5 (T-Case)
43		10 Amp Red	Lt Park Lamps
44		10 Amp Red	Rt Park Lamps
45		20 Amp Yellow	Trailer Tow Park Lamps
46		10 Amp Red	Airbag System # 2
47	—	—	Spare
48	20 Amp Blue		Sunroof/Sound Box
49	30 Amp Pink		Trailer Tow B+
50	40 Amp Green		Anti-Lock Brake System (ABS) Module (Pump)
51	40 Amp Green		Park Lamps
52	—	—	Spare
53	40 Amp Green		Rear Defogger
54	—	—	Spare
55	—	—	Spare
56		10 Amp Red	Heated Seats
57		20 Amp Yellow	Airbag System # 2
58		20 Amp Yellow	Heated Seats
59		10 Amp Red	HVAC Module
60		10 Amp Red	ABS Module
61		20 Amp Yellow	Front Control Module (FCM) 3 (Reverse Lamps)

MAINTAINING YOUR VEHICLE

CAUTION!

- When installing the integrated power module cover, it is important to ensure the cover is properly positioned and fully latched. Failure to do so may allow water to get into the integrated power module and possibly result in an electrical system failure.
- When replacing a blown fuse, it is important to use only a fuse having the correct amperage rating. The use of a fuse with a rating other than indicated may result in a dangerous electrical system overload. If a properly rated fuse continues to blow, it indicates a problem in the circuit that must be corrected.

TIRE PRESSURES

- Check the inflation pressure of each tire, including the spare tire, at least monthly and inflate to the recommended pressure for your vehicle.
- The tire pressures recommended for your vehicle are found on the “Tire and Loading Information” label located on the driver’s side door opening.

NOTE: Refer to the Owner’s Manual on the DVD for more information regarding tire warnings and instructions.

WARNING!

- Overloading of your tires is dangerous. Overloading can cause tire failure, affect vehicle handling, and increase your stopping distance. Use tires of the recommended load capacity for your vehicle. Never overload them.
- Improperly inflated tires are dangerous and can cause collisions. Under-inflation is the leading cause of tire failure and may result in severe cracking, component separation, or “blow out”. Over-inflation reduces a tire’s ability to cushion shock. Objects on the road and chuck holes can cause damage that results in tire failure. Unequal tire pressures can cause steering problems. You could lose control of your vehicle. Over-inflated or under-inflated tires can affect vehicle handling and can fail suddenly, resulting in loss of vehicle control.

WHEEL AND WHEEL TRIM CARE

- All wheels and wheel trim, especially aluminum and chrome plated wheels, should be cleaned regularly with a mild soap and water to prevent corrosion.
- To remove heavy soil and/or excessive brake dust, use MOPAR® Wheel Cleaner or equivalent or select a non-abrasive, non-acidic cleaner.

MAINTAINING YOUR VEHICLE

CAUTION!

Do not use scouring pads, steel wool, a bristle brush, or metal polishes. Do not use oven cleaner. These products may damage the wheel's protective finish. Avoid automatic car washes that use acidic solutions or harsh brushes that may damage the wheel's protective finish. Only MOPAR® Wheel Cleaner or equivalent is recommended.

EXTERIOR BULBS

LIGHT BULBS – Exterior	Bulb Number
Tail, Stop, Turn Lamp	3057
Center High-Mounted Stop Lamp (CHMSL)	921
Fog Lamp - If Equipped	9145
Front Park/Turn Signal	3157NA
Front Side Marker	3157NA
Headlamp	H13
License Lamp	168
Cargo Lamp	921
Backup Lamp	3157

CONSUMER ASSISTANCE

CHRYSLER GROUP LLC CUSTOMER CENTER

P.O. Box 21-8004

Auburn Hills, MI 48321-8004

Phone: 1-866-726-4636

CHRYSLER CANADA INC. CUSTOMER CENTER

P.O. Box 1621

Windsor, Ontario N9A 4H6

Phone: 1-800-465-2001 (English)

Phone: 1-800-387-9983 (French)

ASSISTANCE FOR THE HEARING IMPAIRED

- To assist customers who have hearing difficulties, the manufacturer has installed special TDD (Telecommunication Devices for the Deaf) equipment at its customer center. Any hearing or speech impaired customer, who has access to a TDD or a conventional teletypewriter (TTY) in the United States, can communicate with the manufacturer by dialing 1-800-380-CHRY. Canadian residents with hearing difficulties that require assistance can use the special needs relay service offered by Bell Canada. For TTY teletypewriter users, dial 711 and for Voice callers, dial 1-800-855-0511 to connect with a Bell Relay Service operator.

WARNING!

Engine exhaust, some of its constituents, and certain vehicle components contain, or emit, chemicals known to the State of California to cause cancer and birth defects, or other reproductive harm. In addition, certain fluids contained in vehicles and certain products of component wear contain, or emit, chemicals known to the State of California to cause cancer and birth defects, or other reproductive harm.

PUBLICATIONS ORDERING

- If you are the first registered retail owner of your vehicle, you may obtain one free printed copy of the Owner's Manual, Warranty Booklet or Radio Manuals on your DVD by calling 1-866-726-4636 (U.S.) or 1-800-387-1143 (Canada) or by contacting your dealer.
- Replacement User Guide kits or DVDs or, if you prefer, additional printed copies of the Owner's Manual, Warranty Booklet or Radio Manuals may be purchased by visiting www.techauthority.com or by calling 1-800-890-4038 (U.S.) or 1-800-387-1143 (Canada). Visa, Master Card, American Express and Discover orders are accepted. If you prefer mailing your order, please call the above numbers for an order form.

NOTE: A street address is required when ordering manuals (no P.O. Boxes).

NOTE:

- The Owner's Manual and User Guide electronic files are also available on the Chrysler, Jeep, Ram Truck and Dodge websites.

CONSUMER ASSISTANCE

- Click on the "For Owners" tab, select "Owner/Service Manuals", then select your desired model year and vehicle from the drop down lists.

REPORTING SAFETY DEFECTS IN THE 50 UNITED STATES AND WASHINGTON, D.C.

- If you believe that your vehicle has a defect that could cause a collision or cause injury or death, you should immediately inform the National Highway Traffic Safety Administration (NHTSA) in addition to notifying the manufacturer.
- If NHTSA receives similar complaints, it may open an investigation, and if it finds that a safety defect exists in a group of vehicles, it may order a recall and remedy campaign. However, NHTSA cannot become involved in individual problems between you, your authorized dealer, and the manufacturer.
- To contact NHTSA, you may either call the Auto Safety Hotline toll free at 1-888-327-4236 (TTY: 1-800-424-9153), or go to <http://www.safercar.gov>; or write to: Administrator, NHTSA, 1200 New Jersey Avenue, SE., West Building, Washington, D.C. 20590. You can also obtain other information about motor vehicle safety from <http://www.safercar.gov>.

In Canada

- If you believe that your vehicle has a safety defect, you should contact the Customer Service Department immediately. Canadian customers who wish to report a safety defect to the Canadian government should contact Transport Canada, Motor Vehicle Defect Investigations and Recalls at 1-800-333-0510 or go to <http://www.tc.gc.ca/roadsafety/>
- French Canadian customers who wish to report a safety defect to the Canadian government should contact Transport Canada, Motor Vehicle Defect Investigations and Recalls at 1-800-333-0510 or go to <http://www.tc.gc.ca/securiteroutiere/>

MOPAR ACCESSORIES

AUTHENTIC ACCESSORIES BY MOPAR®

- The following highlights just some of the many Authentic Ram Truck Accessories by Mopar featuring a fit, finish, and functionality specifically for your Dakota.
- In choosing Authentic Accessories you gain far more than expressive style, premium protection, or extreme entertainment, you also benefit from enhancing your vehicle with accessories that have been thoroughly tested and factory-approved.
- For the full line of Authentic Ram Truck Accessories by Mopar, visit your local Ram Truck dealership or online at mopar.com.

CHROME:

- Exhaust Tip
- 18" Chrome Cast Aluminum Wheel
- Tubular Side Steps
- Front Air Deflector
- Fuel Filler Door
- Grille

EXTERIOR:

- Under-the-rail Bedliner
- Fiberglass Tonneau Cover
- Snapless Tonneau Cover
- Molded Splash Guards
- Tuner-style Tail lamps
- Bed Extender
- Tri-Fold Tonneau Cover
- Hitch Receiver
- Fender Flares
- Bed Mat

INTERIOR:

- Premium Carpet Floor Mats
- Door Sill Guards
- Slush Mats

ELECTRONICS:

- Portable Navigation Systems
- iPod® Adapter
- Uconnect™ Web (WiFi)
- SIRIUS Satellite Radio

CARRIERS:

- Bed-mount Bike Carrier
- Bed-mount Ski and Snowboard Carrier
- Bed-mount Cargo Basket with Cargo Net
- Sport Utility Bars (accommodates all carriers)
- Diamond Plate Toolbox

iPod® is a registered trademark of Apple, Inc.

- Air Conditioning 21
- Airbag 10
- Alarm, Panic 8
- Anti-Lock Brake System (ABS) 39,40
- Arming Theft System (Security Alarm) 9
- Audio Settings 23,24
- Automatic Headlights 19
- Automatic Transmission
 - Fluid Type 56
- Axle Fluid 56

- Battery
 - Charging System Light 39
- Belts, Seat 9
- Brake Fluid 56
- Brake System
 - Warning Light 38
- Brake/Transmission Interlock 36
- Bulb Replacement 65

- Cargo Compartment 33
- Cargo Light 19
- Change Oil Indicator 40
- Charging System Light 39
- Check Engine Light (Malfunction Indicator Light) 39
- Child Restraint 11
- Child Restraint Tether Anchors 11
- Climate Control 21
- Clock Setting 24
- Cooling System
 - Coolant Capacity 56
- Crates
 - Rear Convenience Storage 33
- Cruise Control (Speed Control) 20
- Cruise Light 20
- Customer Assistance 66

- Defects, Reporting 67
- Defroster, Rear Window 21
- Defroster, Windshield 21
- Dimmer Control 19
- Dimmer Switch, Headlight 19
- Disarming, Theft System 9
- Driver Cockpit 4

- Electronic Speed Control (Cruise Control) 20
- Electronic Throttle Control Warning Light 39
- Engine
 - Compartment 54
 - Malfunction Indicator (Check Engine) 39
 - Oil Selection 56
 - Overheating 40
- Event Data Recorder 52
- Exterior Lights 65

- Fluid Capacities 56
- Fluids 56
- Fog Lights 19
- Four Wheel Drive Operation 32
- Freeing A Stuck Vehicle 51
- Front Heated Seats 16
- Fuel
 - Filler Cap (Gas Cap) 40
 - Specifications 56
- Fuses 61

- Garage Door Opener (HomeLink®) 29
- Gas Cap (Fuel Filler Cap) 40

- Headlights
 - Automatic 19
 - Dimmer Switch 19
 - High Beam 18
- Heated Seats 16
- High Beam/Low Beam Select (Dimmer) Switch 18
- HomeLink® (Garage Door Opener) Transmitter 29
- Hood Release 53

- Instrument Cluster 6
 - Indicators 7
- Instrument Cluster Warning Lights 6,37
- Intermittent Wipers (Delay Wipers) 18
- Introduction 2

- Jack Location 42
- Jump Starting 47

INDEX

- Key Fob 8
- Key Fob Programmable Features 28
- Lane Change Assist 18
- LATCH (Lower Anchors and Tether for Children) 11
- Lights
 - Engine Temperature Warning 38
 - Four-Wheel Drive Indicator 40
 - Transmission Warning 40
 - Turn Signal 18
 - Warning (Instrument Cluster Description) 6
- Maintenance Record 60
- Maintenance Schedule 58
- Malfunction Indicator Light (Check Engine) 39
- Media Center Radio 22,23
- MOPAR® Accessories 68
- Non-Touch-Screen Radio 22
- Oil Change Indicator 40
- Oil Change Indicator, Reset 40
- Oil Pressure Light 39
- Oil, Engine
 - Capacity 56
- Outlet
 - Power 31
- Overheating, Engine 40
- Panic Alarm 8
- Phone (Pairing) 25
- Phone (Uconnect) 25
- Power
 - Outlet (Auxiliary Electrical Outlet) 31
 - Seats 14
 - Steering 56
- Preparation for Jacking 43
- Programmable Electronic Features 28
- Radio
 - Non-Touch-Screen 22
- Radio Operation 22
- Rain Sensitive Wiper System 18
- Recreational Towing 34
- Remote Starting System 8
- Replacement Bulbs 65
- Reporting Safety Defects 67
- Restraints, Child 11
- Seat Belts 9
- Seats 14
 - Adjustment 15
 - Heated 16
 - Power 14
- Seek Button 23
- Setting the Clock 24
- Shift Lock Manual Override 36
- Signals, Turn 18
- Spare Tire 42
- Spark Plugs 56
- Speed Control (Cruise Control) 20
- Starting
 - Remote 8
- Steering
 - Tilt Column 17
- Steering Wheel Audio Controls 25
- Store Radio Presets 24
- Supplemental Restraint System - Airbag 10
- Tailgate 33
- Theft Alarm (Security Alarm) 9
- Theft System Arming 9
- Theft System Disarming 9
- Tilt Steering Column 17
- Tires
 - Air Pressure 64
 - Changing 43
 - Flat Changing 43
 - Jacking 43
 - Pressure Warning Light 37
- Tow Hooks, Emergency 49
- Towing 34
 - 24-Hour Towing Assistance 37
 - Disabled Vehicle 50
 - Recreational 34
- Towing Vehicle Behind a Motorhome 34
- Trailer Towing
 - Trailer and Tongue Weight 34
- Trailer Weight 34

INDEX

Transfer Case		
Fluid	56	
Transmission		
Fluid	56	
Turn Signals	18	
Uconnect™ Phone	25	
Uconnect™ Voice Command	27	
Universal Garage Door Opener (HomeLink®)	29	
Voice Command	27	
Warning Lights	37	
Washers, Windshield	18	
Wheel and Wheel Trim Care	64	
Wind Buffeting	21	
Windshield Washers	18	
Windshield Wipers	18	



Driving and Alcohol: Drunken driving is one of the most frequent causes of collisions. Your driving ability can be seriously impaired with blood alcohol levels far below the legal minimum. If you are drinking, don't drive. Ride with a designated non-drinking driver, call a cab, a friend, or use public transportation.

WARNING!

Driving after drinking can lead to a collision. Your perceptions are less sharp, your reflexes are slower, and your judgment is impaired when you have been drinking. Never drink and then drive.

RAMTRUCKS.COM

This guide has been prepared to help you get quickly acquainted with your new RAM and to provide a convenient reference source for common questions. However, it is not a substitute for your Owner's Manual.

For complete operational instructions, maintenance procedures and important safety messages, please consult your Owner's Manual, Navigation/Media Center Manuals, Multimedia User Manual and other Warning Labels in your vehicle.

Not all features shown in this guide may apply to your vehicle. For additional information on accessories to help personalize your vehicle, visit www.mopar.com or your local RAM dealer.



11ND33-926-AA
Dakota
Sixth Edition
User Guide

