



DAKOTA

USER GUIDE **2010**



IMPORTANT: This User Guide is intended to familiarize you with the important features of your vehicle. The DVD enclosed contains your Owner's Manual, Navigation/Media Center Manuals, Warranty Booklets, Tire Warranty and 24-Hour Towing Assistance (new vehicles purchased in the U.S.) or Roadside Assistance (new vehicles purchased in Canada) in electronic format. We hope you find it useful. If you are the first registered owner of your vehicle, you may obtain a printed copy of the Owner's Manual, Navigation/Media Center Manuals or Warranty Booklet by calling 1-866-726-4636 (U.S.) or 1-800-387-1143 (Canada) or by contacting your dealer. Replacement DVD kits may be purchased by visiting www.techauthority.com.
Copyright © 2010 Chrysler Group LLC.

TABLE OF CONTENTS

INTRODUCTION/WELCOME

| | |
|---|---|
| WELCOME FROM CHRYSLER GROUP LLC | 2 |
|---|---|

CONTROLS AT A GLANCE

| | |
|------------------------------|---|
| DRIVER COCKPIT | 4 |
| INSTRUMENT CLUSTER | 6 |

GETTING STARTED

| | |
|---------------------------------|----|
| KEY FOB | 8 |
| THEFT ALARM | 9 |
| SEAT BELT | 9 |
| CHILD RESTRAINTS | 9 |
| FRONT SEATS | 13 |
| HEATED SEATS | 14 |
| TILT STEERING COLUMN | 15 |
| PROGRAMMABLE FEATURES | 15 |

OPERATING YOUR VEHICLE

| | |
|--|----|
| TURN SIGNALS/WIPER/WASHER/HIGH BEAMS LEVER | 17 |
| HEADLIGHT SWITCH | 18 |
| SPEED CONTROL | 19 |
| CLIMATE CONTROLS | 20 |
| POWER SUNROOF | 20 |
| WIND BUFFETING | 21 |

ELECTRONICS

| | |
|---|----|
| NON-TOUCH-SCREEN RADIOS | 22 |
| NAVIGATION TOUCH-SCREEN RADIO | 25 |
| STEERING WHEEL AUDIO CONTROLS | 28 |
| UNIVERSAL GARAGE DOOR OPENER (HOMELINK [®]) | 28 |
| POWER OUTLET | 30 |
| Uconnect [™] Phone | 30 |
| VOICE COMMAND | 32 |

OFF-ROAD CAPABILITIES

| | |
|--------------------------------------|----|
| FOUR-WHEEL DRIVE OPERATION | 33 |
|--------------------------------------|----|

UTILITY

| | |
|---|----|
| REAR CRATE 'N GO [®] STORAGE | 34 |
| REAR CARGO AREA UTILITY RAILS | 34 |
| TAILGATE | 34 |

| | |
|---|----|
| TRAILER TOWING WEIGHTS (MAXIMUM TRAILER WEIGHT RATINGS) | 35 |
| RECREATIONAL TOWING (BEHIND MOTORHOME, ETC.) | 35 |
| BRAKE/TRANSMISSION INTERLOCK SYSTEM | 37 |

WHAT TO DO IN EMERGENCIES

| | |
|---|----|
| 24-HOUR TOWING ASSISTANCE - U.S. ONLY | 38 |
| INSTRUMENT CLUSTER WARNING LIGHTS | 38 |
| IF YOUR ENGINE OVERHEATS | 41 |
| JACKING AND TIRE CHANGING | 42 |
| JUMP-STARTING | 48 |
| EMERGENCY TOW HOOKS | 51 |
| TOWING A DISABLED VEHICLE | 52 |
| FREEDING A STUCK VEHICLE | 53 |
| EVENT DATA RECORDER (EDR) | 54 |

MAINTAINING YOUR VEHICLE

| | |
|-------------------------------------|----|
| OPENING THE HOOD | 55 |
| ENGINE COMPARTMENT | 56 |
| FLUIDS AND CAPACITIES | 58 |
| MAINTENANCE CHART | 60 |
| FUSES | 62 |
| TIRE PRESSURES | 65 |
| WHEEL AND WHEEL TRIM CARE | 65 |
| EXTERIOR BULBS | 66 |

CONSUMER ASSISTANCE

| | |
|---|----|
| CHRYSLER GROUP LLC CUSTOMER CENTER | 67 |
| CHRYSLER CANADA INC. CUSTOMER CENTER | 67 |
| ASSISTANCE FOR THE HEARING IMPAIRED | 67 |
| PUBLICATIONS ORDERING | 67 |
| REPORTING SAFETY DEFECTS IN THE 50 UNITED STATES AND WASHINGTON, D.C. | 68 |
| TIRE WARRANTY | 68 |

MOPAR ACCESSORIES

| | |
|--|----|
| MOPAR [®] ACCESSORIES | 71 |
|--|----|

INTRODUCTION/WELCOME

WELCOME FROM CHRYSLER GROUP LLC

Congratulations on selecting your new Chrysler Group LLC vehicle. Be assured that it represents precision workmanship, distinctive styling, and high quality - all essentials that are traditional to our vehicles.

This guide illustrates and describes the operation of features and equipment that are either standard or optional on this vehicle. This guide may also include a description of features and equipment that are no longer available or were not ordered on this vehicle. Please disregard any features and equipment described in this guide that are not available on this vehicle. Chrysler Group LLC reserves the right to make changes in design and specifications and/or make additions to or improvements to its products without imposing any obligation upon itself to install them on products previously manufactured.

For complete owner information, refer to the DVD in the owner's kit provided at the time of new vehicle purchase. For your convenience, the information contained on the DVD may also be printed and saved for future reference.

Chrysler Group LLC is committed to protecting our environment and natural resources. By converting from paper to electronic delivery for the majority of the user information for your vehicle, together we greatly reduce the demand for tree-based products and lessen the stress on our environment.

Vehicles Sold In Canada

With respect to any Vehicles sold in Canada, the name Chrysler Group LLC shall be deemed to be deleted and the name Chrysler Canada Inc. used in substitution therefore.

Driving And Alcohol

Drunken driving is one of the most frequent causes of accidents.

Your driving ability can be seriously impaired with blood alcohol levels far below the legal minimum. If you are drinking, don't drive. Ride with a designated non-drinking driver, call a cab, a friend, or use public transportation.

WARNING!

Driving after drinking can lead to an accident. Your perceptions are less sharp, your reflexes are slower, and your judgment is impaired when you have been drinking. Never drink and then drive.

INTRODUCTION/WELCOME

CAUTION!

Never park your vehicle over dry grass or other combustible materials. The heat from your vehicle exhaust system could cause a fire.

CHRYSLER, DODGE, JEEP, ATF+4, MOPAR and Uconnect are registered trademarks of Chrysler Group LLC.

COPYRIGHT ©2010 CHRYSLER GROUP LLC



CONTROLS AT A GLANCE

DRIVER COCKPIT



CONTROLS AT A GLANCE













*If Equipped

CONTROLS AT A GLANCE





INSTRUMENT CLUSTER

Warning Lights

-  - Low Fuel Warning Light
-  - Charging System Light**
-  - Oil Pressure Warning Light**
-  - Anti-Lock Brake (ABS) Light**
-  - Airbag Warning Light**
-  - Electronic Throttle Control (ETC) Light
-  - Tire Pressure Monitoring System (TPMS) Light
-  - Engine Temperature Warning Light
-  - Transmission Temperature Warning Light
-  - Seat Belt Reminder Light







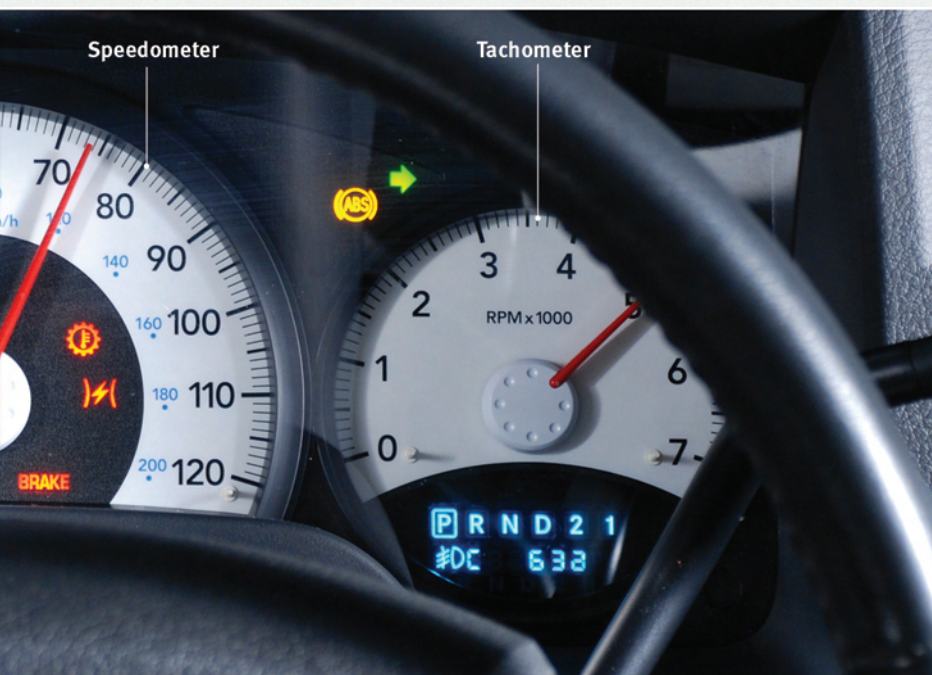



BRAKE

-  - Brake Warning Light**
-  - Malfunction Indicator Light (MIL)**
-  - SERV (Service) 4WD Indicator Light

CONTROLS AT A GLANCE



Indicators

-  - Turn Signal Indicators
-  - High Beam Indicator
-  - Front Fog Light Indicator
-  - Vehicle Security Indicator*
-  - TOW/HAUL Indicator
-  - 4WD LOW Indicator
-  - Cruise Indicator
-  - 4WD Indicator
-  - 4WD LOW Indicator
-  - Cargo Lamp Indicator

Odometer Messages

door - Door Ajar

gASCAP - Fuel Cap Fault

LoW WASH- Low Washer Fluid

* If equipped

** Bulb Check with Key On

LoW tirE - Low Tire Pressure

noFUSE* - Fuse Fault

CHAngE OIL* - Change Engine Oil

GETTING STARTED

KEY FOB



Locking And Unlocking The Doors

- Press the LOCK button once to lock all the doors. Press the UNLOCK button once to unlock the driver's door only and twice within five seconds to unlock all the doors.
- All doors can be programmed to unlock on the first press of the UNLOCK button. Refer to Programmable Features in this guide.

WARNING!

Leaving unattended children in a vehicle is dangerous for a number of reasons. A child or others could be severely injured or killed. Children should be warned not to touch the parking brake, brake pedal, or the shift lever. Do not leave the key in the ignition. A child could operate power windows, other controls, or move the vehicle.

Remote Start

- Press the REMOTE START button  twice within five seconds. Pressing the REMOTE START button a third time shuts the engine off.
- To drive the vehicle, press the UNLOCK button, insert the key in the ignition and turn to the ON/RUN position.
- With remote start, the engine will only run for 15 minutes (timeout) unless the ignition key is placed in the ON/RUN position.
- The vehicle must be started with the key after two consecutive timeouts.

WARNING!

- Do not start or run an engine in a closed garage or confined area. Exhaust gas contains Carbon Monoxide (CO) which is odorless and colorless. Carbon Monoxide is poisonous and can cause serious injury or death when inhaled.
- Keep Key Fob transmitters away from children. Operation of the Remote Start System, windows, door locks or other controls could cause serious injury or death.

GETTING STARTED

Panic Alarm

- Press the PANIC button once to turn the panic alarm on.
- Wait approximately three seconds and press the button a second time to turn the panic alarm off.

THEFT ALARM

To Arm

- Press the Key Fob LOCK button or the power door lock switch while the door is open.

To Disarm

- Press the Key Fob UNLOCK button and turn the ignition to the ON/RUN position.

SEAT BELT

- Be sure everyone in your vehicle is in a seat and using a seat belt properly.

WARNING!

In a collision, you and your passengers can suffer much greater injuries if you are not properly buckled up. You can strike the interior of your vehicle or other passengers, or you can be thrown out of the vehicle. Always be sure you and others in your vehicle are buckled up properly.

CHILD RESTRAINTS

- Children 12 years and under should ride properly buckled up in a rear seat, if available. According to crash statistics, children are safer when properly restrained in the rear seats rather than in the front.
- Every state in the United States and all Canadian provinces require that small children ride in proper restraint systems. This is the law, and you can be prosecuted for ignoring it.

WARNING!

In a collision, an unrestrained child, even a tiny baby, can become a projectile inside the vehicle. The force required to hold even an infant on your lap could become so great that you could not hold the child, no matter how strong you are. The child and others could be severely injured or killed. Any child riding in your vehicle should be in a proper restraint for the child's size.

GETTING STARTED

Installing The LATCH - Compatible Child Restraint System

- Your vehicle is equipped with the child restraint anchorage system called LATCH, which stands for Lower Anchors and Tether for Children.

Extended Cab

- The Extended Cab front and right rear (if equipped with a rear seat) passenger seating positions have lower anchorages that are capable of accommodating LATCH compatible child seats having flexible, webbing mounted lower attachments.

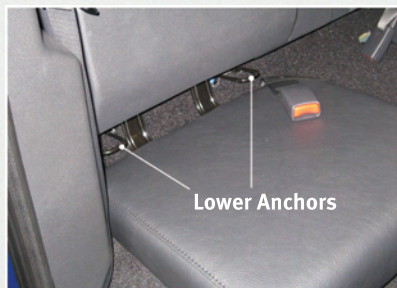

- Loosen the adjusters on the lower straps and tether straps so that you can attach the hook or connector to the lower and tether anchorages more easily.
- Attach the lower hooks or connectors over the top of the anchorage bars, pushing aside the seat cover material. You will easily feel the anchorage bars if you run your finger along the intersection of the seatback and seat cushion surfaces.

Tether Strap at the Front Passenger Seat (Extended Cab)

- Route the child restraint tether strap up and over the front passenger seatback, and under the head restraint.
- Connect the tether strap to the lower anchor located at the bottom rear of the seat.
- Remove the slack in the tether strap so that it is pulled tight.

Tether Straps at the Rear Passenger Seat (Extended Cab)

- Route the child restraint tether strap through the routing loop, located directly behind the child restraint. The routing loops are located behind the flip-down door on the cab back panel (padded bolster).

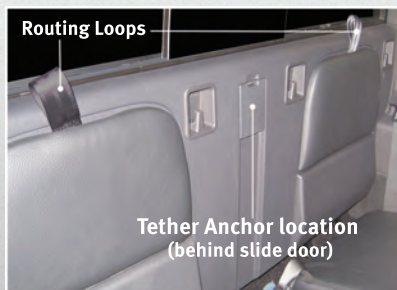

- Route the tether strap across to the center tether anchorage. The center tether is located behind the slide door in the center of the vehicle, between the two seating positions.
- Remove the slack in the tether strap so that the anchor strap is pulled tight.

GETTING STARTED

Crew Cab

- The Crew Cab second row seat has lower anchorages that are capable of accommodating LATCH compatible child seats having flexible, webbing mounted lower attachments at all three seating positions.



- Child seats with fixed lower attachments must be installed in the outboard positions only.
 - **Never** install LATCH-compatible child seats such that two seats share a common lower anchorage.
 - Loosen the adjusters on the lower straps and tether straps so that you can attach the hook or connector to the lower and tether anchorages more easily.
- Attach the lower hooks or connectors over the top of the anchorage bars, pushing aside the seat cover material. You will easily feel the anchorage bars if you run your finger along the intersection of the seatback and seat cushion surfaces.

Tether Straps at the Rear Passenger Seat (Crew Cab)

- Route the child restraint tether strap over the seatback and under the head restraint (for outboard seating position only) and through the anchor strap outer loop (webbing material loop) located directly behind the child restraint.

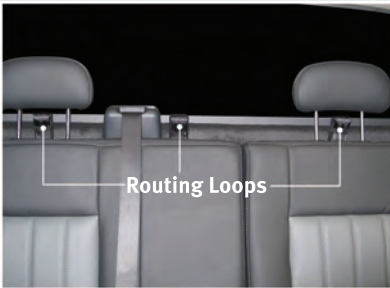

- Connect the tether strap hook to the anchor strap inner metal ring in the ADJACENT seating position.
- Remove the slack in the tether strap so that both anchor straps are pulled tight.

GETTING STARTED

NOTE: Two anchors must be used for any of the three seating positions.

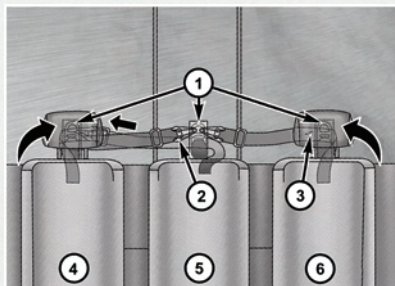

1. Inner Anchor Strap Ring(s)
2. Snap Hook
3. Tether Strap
4. Passenger's Side Rear Child Seat
5. Rear Center Child Seat
6. Driver's Side Rear Child Seat

WARNING!

- Improper installation of a child restraint to the LATCH anchorages can lead to failure of an infant or child restraint. The child could be severely injured or killed. Follow the manufacturer's directions exactly when installing an infant or child restraint.
- An incorrectly anchored tether strap could lead to increased head motion and possible injury to the child. Use only the anchor positions directly behind the child seat to secure a child restraint top tether strap.

Installing The Child Restraint Using The Vehicle Seat Belts

- To install a child restraint, first, pull enough of the seat belt webbing from the retractor to route it through the belt path of the child restraint and slide the latch plate into the buckle.
- Next, extract all the seat belt webbing out of the retractor and then allow the belt to retract into the retractor. Finally, pull on any excess webbing to tighten the lap portion around the child restraint. Any seat belt system will loosen with time, so check the belt occasionally, and pull it tight if necessary.
- Once you have completed securing the child restraint with the seat belt, secure the top tether strap as described on the previous pages.

WARNING!

Rearward-facing child seats must **NEVER** be used in the front seat of a vehicle with a front passenger airbag. An airbag deployment could cause severe injury or death to infants in this position.

GETTING STARTED

FRONT SEATS

WARNING!

Adjusting a seat while the vehicle is moving is dangerous. The sudden movement of the seat could cause you to lose control. The seat belt might not be properly adjusted, and you could be severely injured or killed. Only adjust a seat while the vehicle is parked.

Manual Seat Adjustment

Forward/Rearward

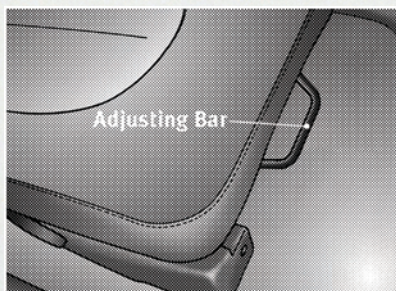

- Lift up on the adjusting bar located at the front of the seat near the floor and release bar to lock seat at the desired position.

Lumbar Support/Recliner



- Rotate the lumbar knob, located on the left-side of the driver's seat, to increase or decrease the amount of lumbar support.
- Lean forward slightly, lift the recline lever located on the outboard side of the seat, then push back to the desired position and release the lever.
- Lean forward and lift the recline lever to return the seatback to its normal position.

WARNING!

Do not ride with the seatback reclined so that the shoulder belt is no longer resting against your chest. In a collision, you could slide under the seat belt and be severely injured or killed. Use the recliner only when the vehicle is parked.

GETTING STARTED

Six-Way Power Seat Adjuster — Driver's Side Only

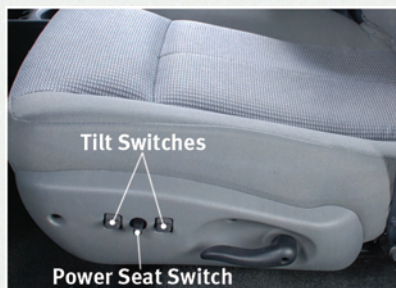

- The power seat controls are located on the outboard side of the driver's seat cushion.
- The power seat switch controls the forward, backward, up, or down adjustment.
- The two tilt switches control the tilt up or down adjustment.

CAUTION!

DO NOT place any article under a power seat or impede its ability to move as it may cause damage to the seat controls. Seat travel may become limited if movement is stopped by an obstruction in the seat's path.

HEATED SEATS

Front Heated Seats



- The heated seat switches are located on the center of the instrument panel.
- After turning the ignition ON, press the switch once to select High-level heating. Press the switch a second time to select Low-level heating. Press the switch a third time to shut the heating elements Off.

WARNING!

- Persons who are unable to feel pain to the skin because of advanced age, chronic illness, diabetes, spinal cord injury, medication, alcohol use, exhaustion or other physical conditions must exercise care when using the seat heater. It may cause burns even at low temperatures, especially if used for long periods of time.
- Do not place anything on the seat that insulates against heat, such as a blanket or cushion. This may cause the seat heater to overheat. Sitting in a seat that has been overheated could cause serious burns due to the increased surface temperature of the seat.

GETTING STARTED

CAUTION!

Repeated overheating of the seat could damage the heating element and/or degrade the material of the seat.

TILT STEERING COLUMN

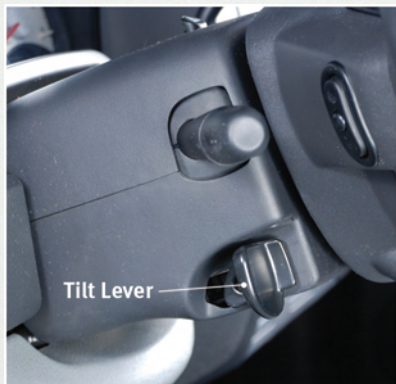

- The tilt lever is located on the steering column, below the turn signal lever.
- Pull the lever toward the steering wheel to unlock the steering column.
- With one hand firmly on the steering wheel, move the steering column up or down as desired.
- Push the lever away from the steering wheel to lock the column firmly in place.

WARNING!

Tilting the steering column while the vehicle is moving is dangerous. Without a stable steering column, you could lose control of the vehicle and have an accident. Adjust the column only while the vehicle is stopped. Be sure it is locked before driving.

PROGRAMMABLE FEATURES

- The following features may be programmed using the Key Fob transmitter or the ignition switch and driver's door lock switch.

NOTE: Pressing the LOCK button while you are inside the vehicle will activate the Vehicle Security Alarm. Opening a door with the Vehicle Security Alarm activated will cause the alarm to sound. Press the UNLOCK button to deactivate the Vehicle Security Alarm.

Unlock On First Press

- To unlock either the driver's side, or all doors, on the first press of the UNLOCK button:
 - Press and hold the LOCK button for at least 4 seconds, but no longer than 10 seconds. Then, press and hold the UNLOCK button while still holding the LOCK button.
 - Release both buttons at the same time.

GETTING STARTED

Auto Unlock Doors On Exit

- To have all of the vehicle doors unlock when any door is opened:
 - Enter your vehicle and close all the doors.
 - Fasten your seatbelt.
 - Within 15 seconds, cycle the ignition switch between LOCK and ON and then back to LOCK four times, ending up in the LOCK position (do not start the engine).
 - Press the power door UNLOCK switch to unlock the doors. A single chime will indicate that programming is complete.

Auto Door Lock

- To have the doors lock automatically when the vehicle's speed exceeds 15 mph (24 km/h):
 - Enter your vehicle and close all the doors.
 - Fasten your seatbelt.
 - Within 10 seconds, cycle the ignition switch between LOCK and ON and then back to LOCK four times, ending up in the LOCK position (do not start the engine).
 - Press the power door LOCK switch to lock the doors. A single chime will indicate that programming is complete.

Sound Horn With Lock

- To turn the horn chirp on or off when the doors are locked:
 - Press the LOCK button for at least 4 seconds, but no longer than 6 seconds. Then, press the PANIC button while still holding the LOCK button. A single chime will sound to indicate that this feature has changed.
 - Release both buttons at the same time.

Flashing Lights With Lock

- The turn signal lights flashing, when the doors are locked or unlocked, feature can be turned on or off. To turn this feature on or off:
 - Press and hold the UNLOCK button for at least 4 seconds, but no longer than 6 seconds. Then, press and hold the LOCK button while still holding the UNLOCK button. A single chime will sound to indicate that this feature has changed.
 - Release both buttons at the same time.

OPERATING YOUR VEHICLE

TURN SIGNALS/WIPER/WASHER/HIGH BEAMS LEVER

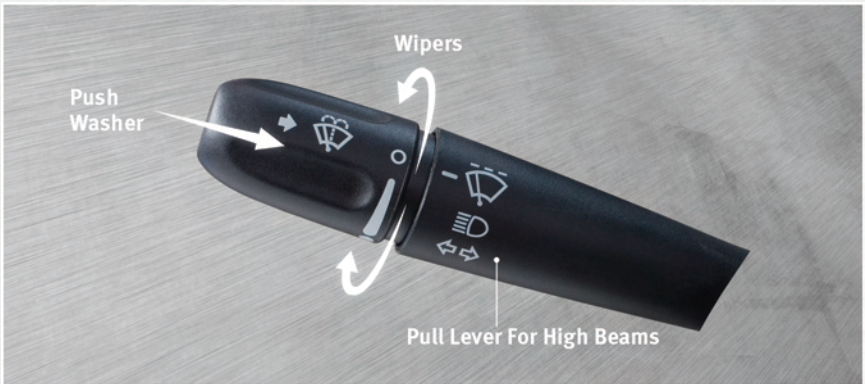

Turn Signals/Lane Change Assist

- Tap the lever up or down once and the turn signal (right or left) will flash three times and automatically turn off.

Wipers

Intermittent, Low And High Operation

- Rotate the end of the lever to the first detent position for one of five intermittent settings, the second detent for low wiper operation and the third detent for high wiper operation.

Washer Operation

- Push the end of the lever inward to the second detent and hold for as long as spray is desired.

High Beams

- Pull the lever toward you to activate the high beams.
- A high beam symbol will illuminate in the cluster to indicate the high beams are on.

NOTE: For safe driving, turn off high beams when oncoming traffic is present to prevent headlight glare and as a courtesy to other motorists.

OPERATING YOUR VEHICLE

HEADLIGHT SWITCH



Automatic Headlights/Parking Lights/Headlights

- Rotate the headlight switch, located on the instrument panel to the left of the steering wheel, to the first detent for parking lights and to the second detent for headlights.
- Rotate the headlight switch to “A” for AUTO headlights.
- When set to “A” (AUTO), the system automatically turns the headlights on or off based on ambient light levels.

Instrument Panel Dimmer

- Rotate the dimmer control to the extreme bottom position to fully dim the instrument panel lights and prevent the interior lights from illuminating when a door is opened.
- Rotate the dimmer control up to increase the brightness of the instrument panel when the parking lights or headlights are on.
- Rotate the dimmer control up to the next detent position to fully brighten the odometer and radio when the parking lights or headlights are on. Refer to your Media Center/Radio User Manual on the DVD for display dimming.
- Rotate the dimmer control up to the last detent position to turn on the interior lighting.

Cargo Light

- The cargo light is strategically placed lighting that helps illuminate the bed area of the truck. A cargo light symbol will illuminate in the cluster to indicate the light is on.
- Push the button to turn ON/OFF the cargo lighting.

OPERATING YOUR VEHICLE

SPEED CONTROL



Cruise ON/OFF

- Push the ON/OFF switch to activate the Speed Control.
- CRUISE will appear in the instrument cluster to indicate the Speed Control is on.
- Push the ON/OFF switch a second time to turn the system off.

Set

- With the Speed Control on, push and release the SET switch to set a desired speed.

Accel/Decel

- Push and hold the RESUME/ACCEL switch to accelerate or push and hold the DECEL switch to decelerate the vehicle; release the switch to save the new set speed.
- Once a speed is set, pushing the RESUME/ACCEL switch once or the DECEL switch once will increase or decrease the set speed approximately 1 mph (2 km/h).

Resume

- To resume a previously selected set speed in memory, push the RESUME/ACCEL switch and release.

Cancel

- Push the CANCEL switch, or apply the brakes or clutch, to cancel the set speed and maintain the set speed memory.
- Push the ON/OFF switch to turn the system off and erase the set speed memory.

OPERATING YOUR VEHICLE

CLIMATE CONTROLS

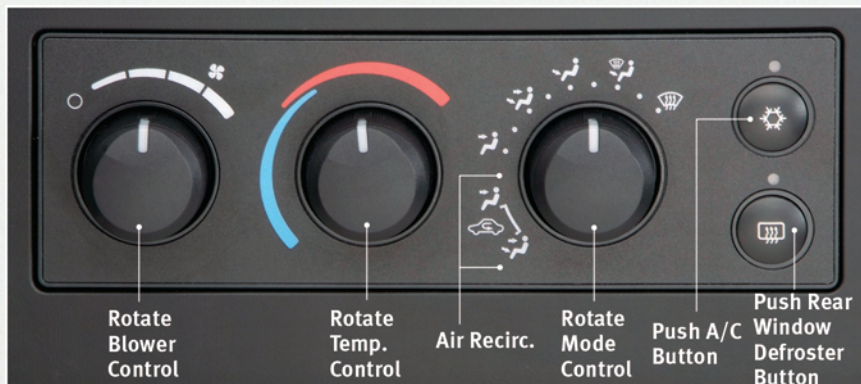

Air Recirculation

- Use recirculation for maximum A/C operation.
- For window defogging, turn the recirculation off.
- Recirculation is not allowed in defrost, floor, defrost/floor (mix) modes.

POWER SUNROOF

- The power sunroof switch is located on the overhead console.

WARNING!

- Never leave children in a vehicle with the key in the ignition switch. Occupants, particularly unattended children, can become entrapped by the power sunroof while operating the power sunroof switch. Such entrapment may result in serious injury or death.
- In an accident, there is a greater risk of being thrown from a vehicle with an open sunroof. You could also be seriously injured or killed. Always fasten your seat belt properly and make sure all passengers are properly secured too.
- Do not allow small children to operate the sunroof. Never allow your fingers, other body parts, or any object to project through the sunroof opening. Injury may result.

Opening Sunroof

Express

- Press the switch rearward and release. The sunroof will fully open and stop automatically.

OPERATING YOUR VEHICLE

Closing Sunroof

Express

- Press the switch forward and release. The sunroof will close automatically from any position.

Manual Open/Close

- Press and hold the switch rearward to open or forward to close the sunroof. Any release of the switch will stop the movement, and the sunroof will remain in a partially open or closed position until the switch is pressed again.

Venting Sunroof

- Press and release the "V" button, and the sunroof will open to the vent position. This is called "Express Vent" and will occur regardless of sunroof position. During Express Vent operation, any movement of the switch will stop the sunroof.

Pinch Protection Feature

- This feature will detect an obstruction in the opening of the sunroof during Express Close operation. If an obstruction in the path of the sunroof is detected, the sunroof will automatically return to the open position.

NOTE: Pinch protection is disabled while the switch is pressed and held during manual opening and closing of the sunroof.

WIND BUFFETING

- Wind buffeting can be described as a helicopter-type percussion sound. If buffeting occurs with the rear windows open, adjust the front and rear windows together.
- If buffeting occurs with the sunroof open, adjust the sunroof opening, or adjust any window. This will minimize buffeting.

ELECTRONICS

NON-TOUCH-SCREEN RADIOS

Media Center 130 (RES)



Media Center 130 (RES/RSC)



Media Center 230 (REQ)

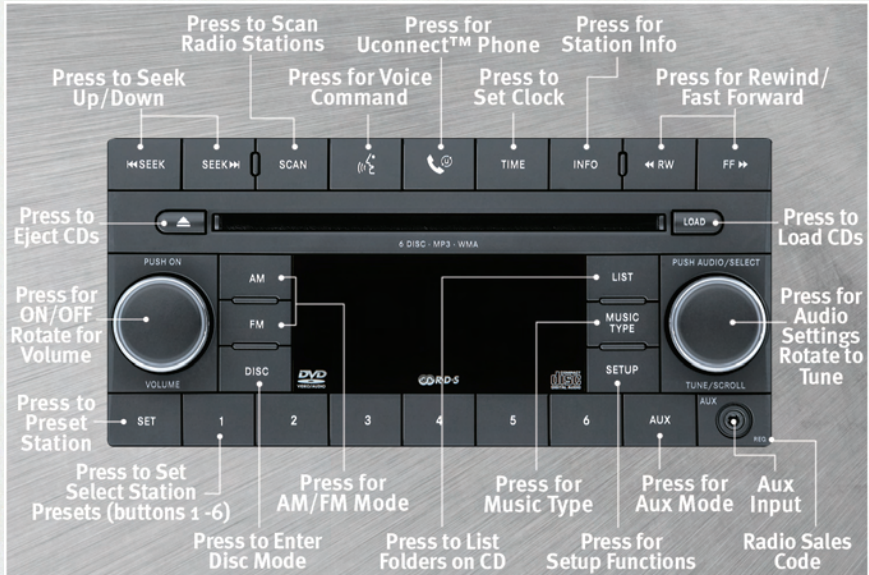

NOTE: Uconnect™ Phone and Voice Command are vehicle options which must be ordered separately. The buttons on the radio will only be active if the vehicle has been equipped with the option.

- Your radio has many features that add to the comfort and convenience of you and your passengers. Some of these radio features should not be used when driving because they take your eyes from the road or your attention from driving.
- The radio sales code is located on the lower right side of the radio faceplate.
- Unless otherwise noted, the information provided on the operation and functionality of the radios in this section is common to all non-touch-screen radios.

Seek Up/Down Buttons

- Press to seek through radio stations in AM, FM or SAT bands. Seek through tracks in CD.
- Holding either button will bypass stations without stopping.

Audio Settings

- Press the TUNE/SCROLL control knob and BASS, MID, TREBLE, BALANCE and FADE will display. Rotate the TUNE/SCROLL control knob to select the desired setting.

ELECTRONICS

Auxiliary Mode

- The auxiliary (AUX) jack allows a portable device, such as an MP3 player or a cassette player, to be plugged into the radio and utilize the vehicle's audio system to amplify the source and play through the vehicle speakers.
- Pressing the AUX button will change the mode to auxiliary device if the AUX jack is connected.
- The control of the external device cannot be provided by the radio; use the device controls instead.

Clock Setting

- Press and hold the TIME button until the hours blink; turn the TUNE/SCROLL control knob to set the hours.
- Press the TUNE/SCROLL control knob until the minutes begin to blink; turn the TUNE/SCROLL control knob to set the minutes.
- Press the TUNE/SCROLL control knob to save the time change.
- To exit, press any button/knob or wait five seconds.

Station Presets

- Press the SET/RND button once and SET 1 will show in the display. Then select the button (1–6).
- A second station may be added to each push button. Press the SET/RND button twice and SET 2 will show in the display, then select button (1–6).

How To Load Multiple CDs/DVDs

REQ Radio Only

- Press the LOAD button and then press the button with the corresponding number (1–6) where the CD is being loaded. The radio will display PLEASE WAIT and prompt when to INSERT DISC.
- After the radio displays INSERT DISC, insert the CD into the player. The radio display will show LOADING DISC when the disc is loading and “READING DISC” when the radio is reading the disc.
- Press the eject button and then the corresponding number (1–6) to eject the desired disc.

NAVIGATION TOUCH-SCREEN RADIO

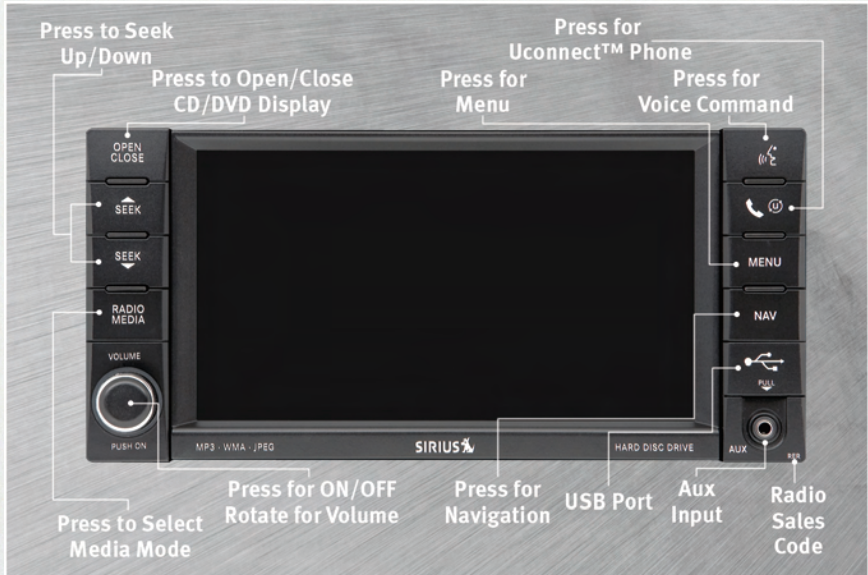

NOTE: Uconnect™ Phone and Voice Command are vehicle options which must be ordered separately. The buttons on the radio will only be active if the vehicle has been equipped with the option.

- The radio sales code is located on the lower right side of the radio faceplate.
- This navigation radio requires digital data from a navigation database. The data in the navigation database is licensed from Navigation Technologies®. Not all roads are digitized.
- For software updates, visit <http://www.chrysler.com/en/owners/mygig/> website, visit <http://www.navteq.com> website, or contact your authorized dealer for the latest available software.

Seek Up/Down

- Press to seek through radio stations in AM, FM, or SAT bands. Seek through tracks in CD or iPod® modes or through songs in the HDD playlist.

Radio Mode

- Press the RADIO/MEDIA hard-key to display the different radio modes, then press desired soft-key to select AM, FM, SAT, HDD or AUX.

Auxiliary Mode

- The auxiliary (AUX) jack allows a portable device, such as an MP3 player or a cassette player, to be plugged into the radio and utilize the vehicle's audio system and play through the vehicle speakers.

Clock Setting

Manually Adjust Time

- Turn the radio on, then touch the screen where the time is displayed.
- Touch the USER CLOCK soft-key.
- To adjust the hours, touch either the HOUR FORWARD or HOUR BACKWARD soft-key.
- To adjust the minutes, touch either the MINUTE FORWARD or MINUTE BACKWARD soft-key.
- To save the new time setting, touch the screen where the word “Save” is displayed.

Store Radio Presets

- Press the RADIO/MEDIA hard-key repeatedly until AM FM SAT is displayed in the upper left corner of the screen.
- Select the radio band by touching either the AM, FM, or SAT soft-key.
- Find the station to store by either pressing the SEEK UP/DOWN hard-key, or touch the SCAN soft-key, DIRECT TUNE soft-key or the left and right arrows.
- Once the station is found, touch and hold one of the PRESET soft-keys in the list to the right until you hear a confirmation beep.

Hard Disc Drive Operation

Copy Complete Audio Disc To Hard-Drive

- Press the OPEN/CLOSE hard-key and insert a disc, then press the MENU hard-key.
- Touch the MY FILES soft-key then select MY MUSIC.
- Touch the IMPORT MUSIC FILES soft-key then touch the FROM DISC soft-key.

Copying From USB

- Insert a USB device then select MY MUSIC.
- Touch the IMPORT MUSIC FILES soft-key, then touch the FROM USB soft-key in the next screen.
- Select the folders or titles you would like to copy, then touch the DONE soft-key to start the copy process.

Copy Pictures To The Hard-Drive

- Insert either a CD or a USB device containing your pictures.
- Touch the MY PICTURES soft-key to get an overview of the currently stored images.
- Press one of the ADD PICTURES soft-keys, then select the type of media inserted.
- Use the PAGE soft-keys to page through a list of pictures and press the picture you would like to import.
- Confirm your selection by touching the YES soft-key. The imported picture is now available in the MANAGE MY PICTURES screen.
- In order to display the imported picture in the radio screen, touch the desired picture soft-key.

- Select this picture by pressing the PICTURE VIEW soft-key. A check mark indicates the currently used picture.

Cleaning Your Touch-Screen Radio

- Do not spray any liquid or caustic chemicals directly on the screen. Use a clean and dry micro fiber lens cleaning cloth in order to clean the touch-screen.
- If necessary, use a lint-free cloth dampened with a cleaning solution such as isopropyl alcohol or an isopropyl alcohol and water solution ratio of 50:50. Be sure to follow the solvent manufacturer's precautions and directions.

Navigation

NOTE: Many features of this radio are speed dependent. For your own safety, it is not possible to use the touch-screen keyboard to enter a name (e.g., street name) while the vehicle is in motion. Pull over at a safe location to complete your task.

- The Navigation system receives GPS signals from satellites to display the position of your vehicle.

New Destination

- Press the NAV hard-key to access the Navigation Main Menu.
- Touch the NEW DESTINATION soft-key to program a destination, then select the destination soft-key of your choice.

Program/Storing Home Address

- Press the NAV hard-key to access the Navigation Main Menu.
- Touch the GUIDE ME HOME soft-key, then touch the STREET ADDRESS soft-key.
- Touch the STATE soft-key, then enter your state name into the speller; select your state from the list and press the CHANGE soft-key.
- Touch the INPUT STREET NAME soft-key and enter your street name into the speller.
- Touch the CONTINUE soft-key and enter your address into the speller; touch the CONTINUE soft-key again.
- Touch the city name and touch the SAVE soft-key to complete programming.

Change Stored Home Address

- Press the MENU hard-key, then touch the MY FILES soft-key.
- Touch the MY ADDRESS BOOK soft-key, then touch the HOME soft-key.
- In the Home Address Information screen touch the EDIT CONTACT soft-key, then touch the CHANGE ADDRESS soft-key in the next screen.
- Touch the INPUT STREET NAME soft-key and enter your street name into the speller.
- Touch the CONTINUE soft-key and enter your address into the speller; touch the CONTINUE soft-key again.
- Touch the city name and touch the SAVE soft-key to complete programming.

ELECTRONICS

Guide Me Home

- Press the NAV hard-key to access the Navigation Main Menu.
- Touch the GUIDE ME HOME soft-key to route you back to your home destination from your current location. Touch the GO soft-key to start your trip.

Map

- Press the NAV hard-key to access the Navigation Main Menu.
- Touch the MAP soft-key to display a map of your current position.

STEERING WHEEL AUDIO CONTROLS



Remote Audio Controls

- The steering wheel audio controls are located on the rear surface of the steering wheel.

Right Switch

- Press the switch up or down to increase or decrease the volume.
- Press the button in the center to change modes AM/FM/CD/SAT.

Left Switch

- Press the switch up or down to search for the next listenable station or select the next or previous CD track.

- Press the button in the center to select the next preset station (radio) or to change CDs if equipped with a CD Changer.

UNIVERSAL GARAGE DOOR OPENER (HomeLink®)



Garage Door Opener

Programming HomeLink®

Begin Programming

- The HomeLink® buttons are located in the overhead console.
 - The Compass Mini-Trip Computer illuminates the HomeLink® symbol along with 1, 2 or 3 indicators under it, when a HomeLink® button is pressed. The indicators will flash at different rates, or remain solid during programming.
- Erase all channels before you begin programming by holding the two outside buttons for up to 20 seconds until the indicators begin to flash.

- Park your vehicle outside of the garage and turn the ignition switch to the ON/RUN position.
- Place the hand-held transmitter 1 to 3 in (3 to 8 cm) from the HomeLink® buttons while keeping the indicator light in view.
- Simultaneously, press and hold both the chosen HomeLink® button and the hand-held transmitter button until the HomeLink® indicator flash rate changes from a slow to a rapidly blinking light, then release both the HomeLink® and the hand-held transmitter buttons. This may take up to 30 seconds, or longer in rare cases.
- Press and hold the just-programmed HomeLink® button; if the indicator light stays on constantly, programming is complete and the garage door should open.

WARNING!

- Your motorized door or gate will open and close while you are programming the universal transceiver. Do not program the transceiver if people or pets are in the path of the door or gate. Only use this transceiver with a garage door opener that has a “stop and reverse” feature as required by Federal safety standards. This includes most garage door opener models manufactured after 1982. Do not use a garage door opener without these safety features. Call toll-free 1-800-355-3515 or, on the Internet, at www.HomeLink.com for safety information or assistance.
- Do not run your vehicle in a closed garage or confined area while programming the transceiver. Exhaust gas from your vehicle contains Carbon Monoxide (CO) which is odorless and colorless. Carbon Monoxide is poisonous and can cause serious injury or death when inhaled.

NOTE: If you are having difficulty programming your HomeLink® and your garage door opener was manufactured after 1995, you may have a rolling code. Follow the steps below for Programming A Rolling Code System.

Programming A Rolling Code System

- At the garage door opener motor (in the garage), locate the “learn” or “programming” button. This can usually be found where the hanging antenna wire is attached to the garage door opener motor (it is NOT the button normally used to open and close the door).
- Firmly press and release the “learn” or “programming” button. The name and color of the button may vary by manufacturer. Within 30 seconds, return to the vehicle and press the programmed HomeLink® button twice (holding the button for two seconds each time). If the device is plugged in and activates, programming is complete.
- If the device does not activate, press the button a third time (for two seconds) to complete the programming.

Using HomeLink®

- To operate, simply press and release the programmed HomeLink® button and the programmed device will operate.

ELECTRONICS

- Refer to your Owner's Manual on the DVD for further details. If you have any problems programming HomeLink[®], or require assistance, please call toll-free 1-800-355-3515 or, on the Internet at www.HomeLink.com.

POWER OUTLET

- There are two 12 Volt electrical outlets on this vehicle.
- The outlet on the front console has power available only when the ignition is in the ON/RUN position. If desired, this outlet can be converted by your authorized dealer to provide power with the ignition switch in the LOCK position.
- The second outlet in the center console is powered directly from the battery (power available at all times). Items plugged into this outlet may discharge the battery and/or prevent engine starting.

NOTE: Do not exceed the maximum power of 160 Watts (13 Amps) at 12 Volts. If the 160 Watt (13 Amp) power rating is exceeded the fuse protecting the system will need to be replaced.

Uconnect™ Phone

- The Uconnect™ Phone is a voice-activated, hands-free, in-vehicle communications system.
- The Uconnect™ Phone allows you to dial a phone number with your cellular phone using simple voice commands.
- For vehicles equipped with Video Entertainment System (VES)[™], refer to the Uconnect™ Phone section of the Uconnect™ User's Manual on the DVD for further details.
- For vehicles not equipped with VES[™], refer to your vehicle Owner's Manual on the DVD for further details.

WARNING!

- Any voice commanded system should be used only in safe driving conditions following local laws and phone use. All attention should be kept on the roadway ahead. Failure to do so may result in an accident causing you and others to be severely injured or killed.
- In an emergency to use Uconnect™ Phone, your cellular phone must be:
 - turned on,
 - paired to Uconnect™ Phone,
 - and have network coverage.

NOTE: The Uconnect™ Phone requires a cellular phone equipped with the Bluetooth[®] Hands-Free Profile, Version 0.96 or higher. For Uconnect™ customer support, call 1-877-855-8400.

Phone Pairing

NOTE: Pairing is a one-time initial setup before using the phone. You will also need to follow the Bluetooth® instructions in your cell phone user guide to complete the phone pairing setup.

- Press the Phone button  to begin.
- Wait for the “ready” prompt and beep.
- (After the BEEP), say “Uconnect setup”.
- (After the BEEP), say “phone pairing”.
- (After the BEEP), say “pair a phone”.
- Follow the audible prompts.
- You will be asked to enter a four-digit Personal Identification Number (PIN), which you will later need to enter into your cellular phone. You can enter any four-digit PIN. You will not need to remember this PIN after the initial pairing process.
- You will then be prompted to give the phone pairing a name (each phone paired should have a unique name).
- Next you will be asked to give this new pairing a priority of 1 thru 7 (up to seven phones may be paired).



Making A Phone Call

- Press the Phone button .
- (After the BEEP), say “dial” (or “call” to a name).
- (After the BEEP), say number (or name).

Phonebook (Uconnect™ Local) Edit

- Press the Phone button .
- (After the BEEP), say “phonebook”.
- (After the BEEP), say “new entry” or “list names” or “delete”.
- Follow the prompts.

Receiving A Call – Accept (And End)

- When an incoming call rings/is announced on Uconnect™, press the Phone button .
- To end a call, press the Phone button .

Mute (Or Unmute) Microphone During Call

- During a call, press the Voice Command button  VR .
- (After the BEEP), say “mute on” (or “mute off”).

Transfer Ongoing Call Between Handset And Vehicle

- During a call, press the Voice Command button  VR .
- (After the BEEP), say “transfer call”.



ELECTRONICS

Changing The Volume

- Start a dialogue by pressing the Phone button , then adjust the volume during a normal call.
- Use the radio ON/OFF VOLUME rotary knob to adjust the volume to a comfortable level while the Uconnect™ system is speaking. Please note the volume setting for Uconnect™ is different than the audio system.

NOTE: To access the tutorial, press the Uconnect™ hard-key. After the BEEP, say “tutorial”. Press any hard-key or touch the display to cancel the tutorial.

VOICE COMMAND

- The Voice Command system allows you to control your AM, FM radio, satellite radio, disc player, Uconnect™ Phone and a memo recorder.
- When you press the Voice Command button  VR located on the radio face plate or steering wheel, you will hear a beep. The beep is your signal to give a command. If you do not say a command within a few seconds, the system will present you with a list of options. If you ever wish to interrupt the system while it lists options, press the Voice Command button  VR, listen for the BEEP, and say your command.
- For vehicles equipped with Video Entertainment System (VES)™, refer to the Voice Command section of the Uconnect™ User's Manual on the DVD for further details.
- For vehicles not equipped with VES™, refer to your vehicle Owner's Manual on the DVD for Voice Command information.

Changing The Volume

- Start a dialogue by pressing the Voice Command button  VR, then say a command (for example, “tutorial”).
- Use the radio ON/OFF VOLUME rotary knob to adjust the volume to a comfortable level while the Voice Command system is speaking. The volume setting for Voice Command is different than the audio system.

WARNING!

Any voice commanded system should be used only in safe driving conditions following local laws and phone use. All attention should be kept on the roadway ahead. Failure to do so may result in an accident causing you and others to be severely injured or killed.

NOTE: To access the tutorial, press the Voice Command button  VR. After the BEEP, say “tutorial”. Press any hard-key or touch the display to cancel the tutorial.

OFF-ROAD CAPABILITIES

FOUR-WHEEL DRIVE OPERATION

- This is an electric-shift transfer case and is operated by the 4WD Control Switch (Transfer Case Switch), which is located on the instrument panel.
- The transfer case provides four mode positions:
 - Two-wheel drive high range (2WD)
 - Four-wheel drive lock range (4WD LOCK)
 - Four-wheel drive low range (4WD LOW)
 - NEUTRAL (N)
- This transfer case is designed to be driven in the two-wheel drive position (2WD) for normal street and highway conditions on dry, hard-surfaced roads.
- When additional traction is required, the transfer case 4WD LOCK and 4WD LOW positions can be used to lock the front and rear driveshafts together and force the front and rear wheels to rotate at the same speed. This is accomplished by rotating the 4WD Control Switch to the desired position. The 4WD LOCK and 4WD LOW positions are designed for loose or slippery road surfaces only.
- Driving in the 4WD LOCK and 4WD LOW positions on dry hard-surfaced roads may cause increased tire wear and damage to the driveline components.

NOTE: The transfer case NEUTRAL position is selected by pressing the recessed button located on the lower left-hand corner of the 4WD Control Switch. The transfer case NEUTRAL position is to be used for recreational towing only.

NOTE: Do not attempt to make a shift while only the front or rear wheels are spinning. The NV233/243 transfer case is not equipped with a synchronizer and, therefore, the front and rear driveshaft speeds must be equal for the shift to take place. Shifting while only the front or rear wheels are spinning can cause damage to the transfer case.

WARNING!

You or others could be injured if you leave the vehicle unattended with the transfer case in the NEUTRAL position without first fully engaging the parking brake. The transfer case NEUTRAL position disengages both the front and rear driveshafts from the powertrain and will allow the vehicle to move regardless of the transmission position. The parking brake should always be applied when the driver is not in the vehicle.

UTILITY

REAR CRATE 'N GO[®] STORAGE



- The rear Crate 'n Go[®] storage, located under the rear seat lower cushion, consists of two removable, collapsible storage crates.
- To open the crates, lift upward on the crate handles and engage the crate end flaps.
- To remove the crate, press on the release lever, located on the ends of the base, and lift up on the crate.
- To install the crate into the base, insert the crate into the inboard slot and push down on the outboard side of the crate, then snap into place.
- To collapse the crate, push the crate end flaps inward to disengage. Push the sides inward and snap into place.

REAR CARGO AREA UTILITY RAILS

- There are four adjustable cleats in the pick-up bed that can be used to assist in securing cargo. Each cleat must be located and tightened down in one of the detents along either rail, in order to keep cargo properly secure.

TAILGATE

Tailgate Removal

- To simplify mounting a camper unit with an overhang, the tailgate can be removed quickly. Follow these steps:
 - Open the tailgate to a 45-degree angle.
 - Unclip and remove the cables from the box while maintaining a 45-degree angle.
 - Lift the tailgate off of the pivot on the passenger side by pulling upward and rearward at the same time.
 - Slide the tailgate to the passenger side while making sure clearance from the box and taillight is maintained.
- To reinstall the tailgate, do the following:
 - Slide the tailgate onto the driver's side pivot.
 - Hold the tailgate at a 45 degree angle and insert it into the passenger side pivot.
 - Clip the cables to the box.

Two-Position Tailgate/Upper Load Platform

- Your tailgate can be opened to the full-open or the partial-open position. The partial-open position is for loading objects longer than the length of the bed (sheets of plywood, etc.) by creating an upper load platform:

Installing Lumber

- Place lumber across the box in the indentations provided above the wheel housings and in the bulkhead dividers, to form the floor. There are indents in the sheet metal (or bed liner if equipped) on the inner side of the box in front (Crew Cab® only) and behind both wheel housings.
- Secure the tailgate in the partially-open position.
- Open the tailgate slightly.
- Snap the tailgate support cable between the cable guide and the tailgate bumper. Do this on both sides of the tailgate.
- To return the tailgate to the full-open position:
 - Lift up on the tailgate.
 - Remove both cables from between the cable guides and the tailgate bumpers, and lower the tailgate.

CAUTION!

- Care should always be exercised when operating a vehicle with cargo. Vehicle speeds may need to be reduced. Severe turns or rough roads may cause shifting or bouncing of the cargo that may result in vehicle damage.

(Continued)

CAUTION! (Continued)

- Ensure the load is securely tied down and is properly identified according to local laws if it extends beyond the tail lights.
- Loading should not exceed 400 lbs (181 kg) of material suspended above the wheelhouse and partially open tailgate or vehicle damage may result.

TRAILER TOWING WEIGHTS (MAXIMUM TRAILER WEIGHT RATINGS)

NOTE: For trailer towing information (maximum trailer weight ratings) refer to the following website addresses:

- <http://www.dodge.com/towing>
- <http://www.dodge.ca> (Canada)

RECREATIONAL TOWING (BEHIND MOTORHOME, ETC.)

Two-Wheel Drive Models

- Recreational towing of two-wheel drive models is not allowable. Towing the vehicle with the transmission in NEUTRAL can cause severe transmission damage. Removal of the driveshaft for towing is not recommended, since this would allow fluid to drain from the transmission.

Four-Wheel Drive Models

CAUTION!

- Internal damage to the transfer case will occur if a front or rear wheel lift is used when recreational towing.
- The transfer case must be shifted into NEUTRAL for recreational towing. The NEUTRAL button is located on the lower left hand corner of the 4WD Control Switch. Shifts into and out of transfer case NEUTRAL can take place with the selector switch in any mode position.
- Automatic transmissions must be placed in PARK position for recreational towing.
- Manual transmissions must be placed in gear (for example, fourth gear) for recreational towing. Failure to follow these procedures can cause severe transmission and/or transfer case damage.

Recreational Towing Procedure

- Use the following procedure to prepare your vehicle for recreational towing.
 - Bring the vehicle to a complete stop, shut the engine OFF and turn the Key Fob to the ON position (do not start the engine).
 - Press the brake pedal and shift the automatic transmission into NEUTRAL, or press the clutch pedal to the floor on a manual transmission.

- Using a ballpoint pen or similar object, press the transfer case NEUTRAL button for four seconds.
- After the shift is completed and the NEUTRAL light comes on, release the NEUTRAL button.
- Start the engine and shift the automatic transmission into REVERSE.
- Release the brake pedal for five seconds and ensure that there is no vehicle movement.
- Repeat the previous step with the transmission in DRIVE.
- Shut the engine OFF, and place the Key Fob in the unlocked OFF position.
- Shift the automatic transmission into PARK. Shift manual transmissions into fourth gear.
- Attach the vehicle to the tow vehicle with a tow bar and disconnect the negative battery cable.
- Refer to your Owner's Manual on the DVD for further details.

CAUTION!

It is necessary to follow these steps to be certain that the transfer case is fully in NEUTRAL before recreational towing to prevent damage to internal parts.

NOTE:

- The first two steps are requirements that must be met prior to pressing the NEUTRAL button, and must continue to be met until the four seconds elapse and the shift has been completed. If any of these requirements (with the exception of Key Fob ON) are not met prior to pressing the NEUTRAL button or are no longer met during the four second timer, then the NEUTRAL indicator light will flash continuously until all requirements are met or until the NEUTRAL button is released.
- The Key Fob must be ON for a shift to take place and for the position indicator lights to be operable. If the Key Fob is not ON, the shift will not take place and no position indicator lights will be on or flashing.
- A Flashing NEUTRAL position indicator light indicates that shift requirements have not been met.

BRAKE/TRANSMISSION INTERLOCK SYSTEM

- This system prevents you from moving the shift lever out of PARK and into any gear unless the brake pedal is pressed.
- This system is active only when the ignition switch is in the ON position.

WHAT TO DO IN EMERGENCIES

24-HOUR TOWING ASSISTANCE - U.S. ONLY

- Dial toll-free 1-800-521-2779 or 1-800-363-4869 for Canadian residents.
- Provide your name, vehicle identification number and license plate number.
- Provide your location, including telephone number, from which you are calling.
- Briefly describe the nature of the problem and answer a few simple questions.
- You will be given the name of the service provider and an estimated time of arrival. If you feel you are in an “unsafe situation”, please let us know. With your consent, we will contact local police or safety authorities.

INSTRUMENT CLUSTER WARNING LIGHTS

(!) - Tire Pressure Monitoring System (TPMS) Light

- Each tire, including the spare (if provided), should be checked monthly, when cold and inflated to the inflation pressure recommended by the vehicle manufacturer on the vehicle placard or tire inflation pressure label. (If your vehicle has tires of a different size than the size indicated on the vehicle placard or tire inflation pressure label, you should determine the proper tire inflation pressure for those tires.)
- As an added safety feature, your vehicle has been equipped with a Tire Pressure Monitoring System (TPMS) that illuminates a low tire pressure telltale when one or more of your tires is significantly under-inflated. Accordingly, when the low tire pressure telltale illuminates, you should stop and check your tires as soon as possible, and inflate them to the proper pressure. Driving on a significantly under-inflated tire causes the tire to overheat and can lead to tire failure. Under-inflation also reduces fuel efficiency and tire tread life, and may affect the vehicle’s handling and stopping ability.
- Please note that the TPMS is not a substitute for proper tire maintenance, and it is the driver’s responsibility to maintain correct tire pressure, even if under-inflation has not reached the level to trigger illumination of the TPMS low tire pressure telltale.
- Your vehicle has also been equipped with a TPMS malfunction indicator to indicate when the system is not operating properly. The TPMS malfunction indicator is combined with the low tire pressure telltale. When the system detects a malfunction, the telltale will flash for approximately one minute and then remain continuously illuminated. This sequence will continue upon subsequent vehicle start-ups as long as the malfunction exists.
- When the malfunction indicator is illuminated, the system may not be able to detect or signal low tire pressure as intended. TPMS malfunctions may occur for a variety of reasons, including the installation of replacement or alternate tires or wheels on the vehicle that prevent the TPMS from functioning properly. Always check the TPMS malfunction telltale after replacing one or more tires or wheels on your vehicle, to ensure that the replacement or alternate tires and wheels allow the TPMS to continue to function properly.

WHAT TO DO IN EMERGENCIES

CAUTION!

The TPMS has been optimized for the original equipment tires and wheels. TPMS pressures and warning have been established for the tire size equipped on your vehicle. Undesirable system operation or sensor damage may result when using replacement equipment that is not of the same size, type, and/or style. Aftermarket wheels can cause sensor damage. Do not use tire sealant from a can, or balance beads if your vehicle is equipped with a TPMS, as damage to the sensors may result.

- Engine Temperature Warning Light

- This light warns of an overheated engine condition.
- If the light turns on and a warning chime sounds while driving, safely pull over and stop the vehicle. If the A/C system is on, turn it off. Also, shift the transmission into NEUTRAL and idle the vehicle. If the temperature reading does not return to normal, turn the engine off immediately.
- We recommend that you do not operate the vehicle or engine damage will occur. Have the vehicle serviced immediately.

WARNING!

A hot engine cooling system is dangerous. You or others could be badly burned by steam or boiling coolant. You may want to call an authorized dealership for service if your vehicle overheats.

BRAKE - Brake Warning Light

- The Brake Warning light illuminates when there is either a system malfunction or the parking brake is applied. If the light is on and the parking brake is not applied, it indicates a possible brake hydraulic malfunction, brake booster problem or an Anti-Lock Brake System problem.
- We recommend you drive to the nearest service center and have the vehicle serviced immediately.

WARNING!

Driving a vehicle with the red brake light on is dangerous. Part of the brake system may have failed. It will take longer to stop the vehicle. You could have an accident. Have the vehicle checked immediately.

- Malfunction Indicator Light (MIL)

- Certain conditions, such as a loose or missing gas cap, poor fuel quality, etc., may illuminate the MIL after engine start. The vehicle should be serviced if the light stays on through several typical driving cycles. In most situations, the vehicle will drive normally and not require towing.

WHAT TO DO IN EMERGENCIES

- If the MIL flashes when the engine is running, serious conditions may exist that could lead to immediate loss of power or severe catalytic converter damage. We recommend you do not operate the vehicle. Have the vehicle serviced immediately.

- Charging System Light

- This light shows the status of the electrical charging system. If the charging system light remains on, it means that the vehicle is experiencing a problem with the charging system.
- We recommend you do not continue driving if the charging system light is on. Have the vehicle serviced immediately.

- Oil Pressure Warning Light

- This light indicates low engine oil pressure. If the light turns on while driving, stop the vehicle and shut off the engine as soon as possible. A chime will sound for four minutes when this light turns on.
- We recommend you do not operate the vehicle or engine damage will occur. Have the vehicle serviced immediately.

- Anti-Lock Brake (ABS) Light

- This light monitors the Anti-Lock Brake System (ABS).
- If the light is not on during starting, stays on, or turns on while driving, we recommend you drive to the nearest service center and have the vehicle serviced immediately.

- Electronic Throttle Control (ETC) Light

- This light informs you of a problem with the Electronic Throttle Control (ETC) system.
- If a problem is detected, the light will come on while the engine is running. Cycle the ignition when the vehicle has completely stopped and the shift lever is placed in the PARK position; the light should turn off.
- If the light remains lit with the engine running, your vehicle will usually be drivable; however, see an authorized dealer for service immediately. If the light is flashing when the engine is running, immediate service is required and you may experience reduced performance, an elevated/rough idle or engine stall and your vehicle may require towing.

- Airbag Warning Light

- If the light is not on during starting, stays on, or turns on while driving, we recommend you drive to the nearest service center and have the vehicle serviced immediately.

- SVC (Service) 4WD Indicator Light

- If the light stays on or comes on during driving, it means that the 4WD system is not functioning properly and that service is required. We recommend you do not operate the vehicle. Have the vehicle serviced immediately.

WHAT TO DO IN EMERGENCIES

- Transmission Temperature Warning Light

- This light indicates that there is excessive transmission fluid temperature that might occur with severe usage such as trailer towing. If this light turns on, stop the vehicle and run the engine at idle, with the transmission in NEUTRAL, until the light turns off. Once the light turns off, you may continue to drive normally.

Fuel Cap/Loose Gas Cap Message

- If a “gas cap” message (shown as gASCAP) appears, tighten the gas cap until a “clicking” sound is heard.
- Press the odometer reset button to turn the message off.
- If the message continues to appear for more than three days after tightening the gas cap, see your authorized dealer.

Oil Change Indicator

Message

- If an “oil change” message (shown as CHAnGE OIL) appears and a single chime sounds, it is time for your next required oil change.

Resetting The Light After Servicing

- Turn the ignition switch to the ON/RUN position (do not start engine).
- Fully depress the accelerator pedal three times within 10 seconds.
- Turn the ignition switch to the OFF/LOCK position.

IF YOUR ENGINE OVERHEATS

- In any of the following situations, you can reduce the potential for overheating by taking the appropriate action.
 - On the highways — slow down.
 - In city traffic — while stopped, shift transmission into NEUTRAL, but do not increase engine idle speed.

NOTE: There are steps that you can take to slow down an impending overheat condition:

- If your air conditioner (A/C) is on, turn it off. The A/C system adds heat to the engine cooling system and turning the A/C off can help remove this heat.
- You can also turn the Temperature Control to maximum heat, the Mode Control to floor and the Fan Control to high. This allows the heater core to act as a supplement to the radiator and aids in removing heat from the engine cooling system.
- If the temperature reading does not return to normal, turn the engine off immediately.
- We recommend that you do not operate the vehicle or engine damage will occur. Have the vehicle serviced immediately.

WHAT TO DO IN EMERGENCIES

CAUTION!

Driving with a hot cooling system could damage your vehicle. If the temperature gauge reads HOT (H), pull over and stop the vehicle. Idle the vehicle with the air conditioner turned off until the pointer drops back into the normal range. If the pointer remains on HOT (H), and you hear continuous chimes, turn the engine off immediately and call for service.

WARNING!

You or others can be badly burned by hot engine coolant (antifreeze) or steam from your radiator. If you see or hear steam coming from under the hood, do not open the hood until the radiator has had time to cool. Never try to open a cooling system pressure cap when the radiator or coolant bottle is hot.

JACKING AND TIRE CHANGING

WARNING!

- Do not attempt to change a tire on the side of the vehicle close to moving traffic. Pull far enough off the road to avoid the danger of being hit when operating the jack or changing the wheel.
- Getting under a jacked-up vehicle is dangerous. The vehicle could slip off the jack and fall on you. You could be crushed. Never get any part of your body under a vehicle that is on a jack. If you need to get under a raised vehicle, take it to a service center where it can be raised on a lift.
- The jack is designed to use as a tool for changing tires only. The jack should not be used to lift the vehicle for service purposes. The vehicle should be jacked on a firm, level surface only. Avoid ice or slippery areas.
- If it is necessary to retrieve the spare tire from under the vehicle on the side of the vehicle close to moving traffic, pull far enough off the road to avoid the danger of being hit.

WHAT TO DO IN EMERGENCIES

Jack Location

Extended Cab



- The scissor jack and tire changing tools are stowed in a compartment under the rear passenger seat.

Crew Cab®



- The scissor jack and tire changing tools are accessed by lifting up the rear passenger seat.
- The jack is secured in place by turning the jack screw until the jack is secured into place.
- A finger-operated helper tool is provided to assist removal and stowage of the jack. This tool must be removed to operate the jack for changing the spare tire.

Spare Tire Stowage

- To remove the spare tire, remove the jack-handle components from the storage compartment and assemble them.
- Attach the wheel wrench to the jack extension tube and insert the tube through the access hole in the rear bumper and into the winch mechanism tube.
- Rotate the wheel wrench handle counterclockwise until the spare tire is on the ground with enough cable slack to allow you to pull it out from under the vehicle.
- When the spare is clear, tilt the retainer at the end of the cable and pull it through the center of the wheel.

WHAT TO DO IN EMERGENCIES

Preparations For Jacking

- Park on a firm, level surface. Avoid ice or slippery areas.

WARNING!

Do not attempt to change a tire on the side of the vehicle close to moving traffic. Pull far enough off the road to avoid being hit when operating the jack or changing the wheel.

- Set the parking brake and shift the automatic transmission into PARK. On Four-Wheel Drive vehicles, shift the transfer case to the 4L position.
- Turn the ignition to LOCK and turn on the Hazard Warning flasher.

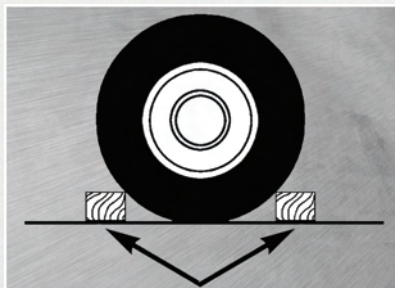

- Block both the front and rear of the wheel diagonally opposite of the jacking position. For example, if changing the right front tire, block the left rear wheel.

NOTE: Passengers should not remain in the vehicle when the vehicle is being jacked.

Jacking And Tire Changing Instructions

WARNING!

Carefully follow these tire changing procedures to help prevent personal injury or damage to your vehicle: Always park on a firm, level surface as far from the edge of the roadway as possible before raising the vehicle.

- Remove the spare tire, jack and tools from their stored location.
- Loosen (but do not remove) the wheel lug nuts by turning them counterclockwise one turn while the wheel is still on the ground.
- Assemble the jack and jacking tools. Connect the jack handle driver to the extension, then to the lug wrench.

WHAT TO DO IN EMERGENCIES

- Place the jack:
 - For front wheels, place the jack under the frame rail behind the wheel. Locate the jack as far forward as possible on the straight part of the frame prior to inboard transition.



WHAT TO DO IN EMERGENCIES

- For rear wheels, place the jack under the axle between the u-bolts attaching the spring to the axle.

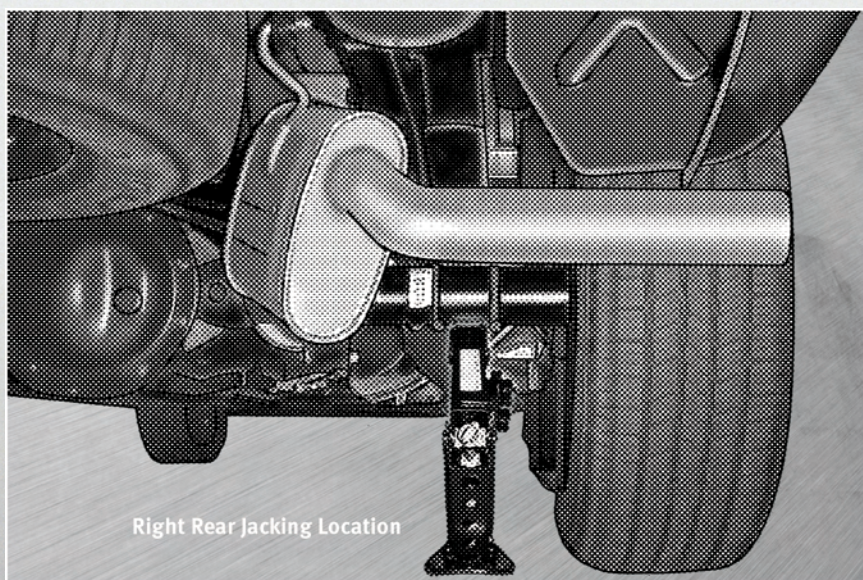
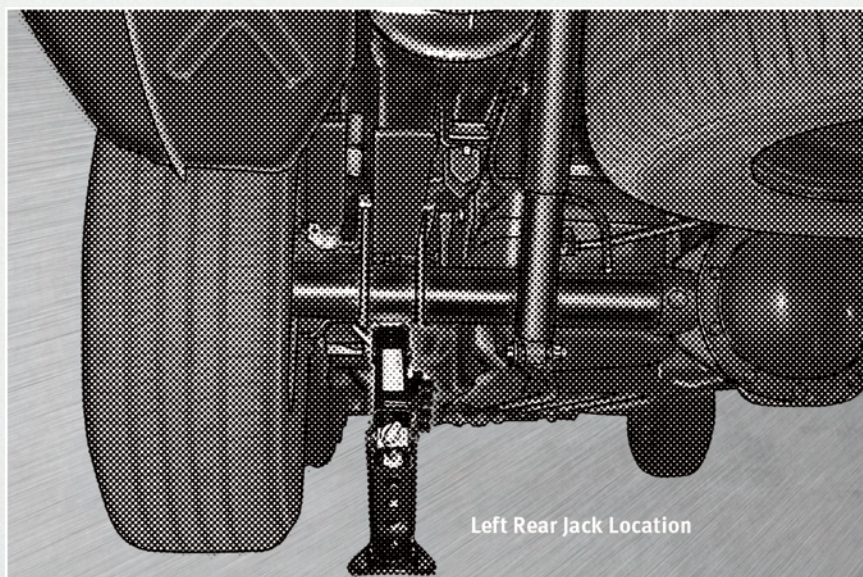

WHAT TO DO IN EMERGENCIES

- Turn the jack screw clockwise to firmly engage the jack saddle with the lift area.
- Raise the vehicle by turning the jack screw clockwise. Raise the vehicle only until the tire just clears the surface and enough clearance is obtained to install the spare tire.

WARNING!

Raising the vehicle higher than necessary can make the vehicle less stable and cause an accident. It could slip off the jack and hurt someone near it. Raise the vehicle only enough to remove the tire.

- Remove the lug nuts and wheel.
- Position the spare wheel/tire on the vehicle and install the lug nuts with the cone-shaped end toward the wheel. Lightly tighten the lug nuts clockwise. To avoid the risk of forcing the vehicle off the jack, do not tighten the nuts fully until the vehicle has been lowered.
- Lower the vehicle by turning the jack screw counterclockwise, and remove the jack and wheel blocks.
- Finish tightening the lug nuts. Push down on the wrench while tightening for increased leverage. Alternate nuts until each one has been tightened twice. The correct wheel nut tightness is 120 to 160 ft lbs (163 to 217 N·m). If in doubt about the correct tightness, have them checked with a torque wrench by your authorized dealer or at a service station.

WARNING!

A loose tire or jack, thrown forward in an accident or hard stop, could endanger the occupants of the vehicle. Always stow the jack parts and the spare tire in the places provided.

- Secure the jack and tools in their proper locations.
- For convenience in checking the spare tire inflation, stow with the valve stem toward the rear of the vehicle. Continue winching up the tire until you hear the winch click three times.

NOTE: To Stow the Flat or Spare: The wheel retainer does not fit through the center of the aluminum wheel. The tire must be stored in a safe manner in the bed of the truck.

WHAT TO DO IN EMERGENCIES

JUMP-STARTING



- If your vehicle has a discharged battery it can be jump-started using a set of jumper cables and a battery in another vehicle or by using a portable battery booster pack.
- Jump-starting can be dangerous if done improperly so please follow the procedures in this section carefully.

NOTE: When using a portable battery booster pack follow the manufacturer's operating instructions and precautions.

CAUTION!

Do not use a portable battery booster pack or any other booster source with a system voltage greater than 12 Volts or damage to the battery, starter motor, alternator or electrical system may occur.

WARNING!

When temperatures are below the freezing point, electrolyte in a discharged battery may freeze. Do not attempt jump-starting because the battery could rupture or explode and cause personal injury. Battery temperature must be brought above freezing point before attempting a jump-start.

WHAT TO DO IN EMERGENCIES

Preparations for Jump-Start

- The battery in your vehicle is located in the front of the engine compartment, behind the left headlight assembly.

WARNING!

- Take care to avoid the radiator cooling fan whenever the hood is raised. It can start anytime the ignition switch is on. You can be injured by moving fan blades.
 - Remove any metal jewelry, such as watch bands or bracelets, that might make an inadvertent electrical contact. You could be seriously injured.
 - Batteries contain sulfuric acid that can burn your skin or eyes and generate hydrogen gas which is flammable and explosive. Keep open flames or sparks away from the battery.
- Set the parking brake, shift the automatic transmission into PARK and turn the ignition to LOCK.
 - Turn off the heater, radio, and all unnecessary electrical accessories.
 - If using another vehicle to jump-start the battery, park the vehicle within the jumper cables reach, set the parking brake and make sure the ignition is OFF.

WARNING!

Do not allow vehicles to touch each other as this could establish a ground connection and personal injury could result.

Jump-Starting Procedure

WARNING!

Failure to follow this procedure could result in personal injury or property damage due to battery explosion.

CAUTION!

Failure to follow these procedures could result in damage to the charging system of the booster vehicle or the discharged vehicle.

- Connect the positive (+) end of the jumper cable to the positive (+) post of the discharged vehicle.
- Connect the opposite end of the positive (+) jumper cable to the positive (+) post of the booster battery.
- Connect the negative end (-) of the jumper cable to the negative (-) post of the booster battery.

WHAT TO DO IN EMERGENCIES

- Connect the opposite end of the negative (-) jumper cable to a good engine ground (exposed metal part of the discharged vehicle's engine) away from the battery and the fuel injection system.

WARNING!

Do not connect the cable to the negative post (-) of the discharged battery. The resulting electrical spark could cause the battery to explode and could result in personal injury.

- Start the engine in the vehicle that has the booster battery, let the engine idle a few minutes, and then start the engine in the vehicle with the discharged battery. Once the engine is started, remove the jumper cables in the reverse sequence:
- Disconnect the negative (-) jumper cable from the engine ground of the vehicle with the discharged battery.
- Disconnect the negative end (-) of the jumper cable from the negative (-) post of the booster battery.
- Disconnect the opposite end of the positive (+) jumper cable from the positive (+) post of the booster battery.
- Disconnect the positive (+) end of the jumper cable from the positive (+) post of the discharged vehicle.
- Reinstall the air intake duct.
- If frequent jump-starting is required to start your vehicle you should have the battery and charging system inspected at your authorized dealer.

CAUTION!

Accessories that can be plugged into the vehicle power outlets draw power from the vehicle's battery, even when not in use (i.e., cellular phones, etc.). Eventually, if plugged in long enough, the vehicle's battery will discharge sufficiently to degrade battery life and/or prevent the engine from starting.

WHAT TO DO IN EMERGENCIES

EMERGENCY TOW HOOKS

- If your vehicle is equipped with tow hooks, they are mounted in the front and the rear.

NOTE: For off-road recovery, it is recommended to use both of the front tow hooks to minimize the risk of damage to the vehicle.

WARNING!

- Chains are not recommended for freeing a stuck vehicle. Chains may break, causing serious injury or death.
- Stand clear of vehicles when pulling with tow hooks. Tow straps and chains may break, causing serious injury.

CAUTION!

Tow hooks are for emergency use only, to rescue a vehicle stranded off-road. Do not use tow hooks for tow truck hookup or highway towing. You could damage your vehicle. Tow straps are recommended when towing the vehicle; chains may cause vehicle damage.

WHAT TO DO IN EMERGENCIES

TOWING A DISABLED VEHICLE

| Model | Flat Towing (all four wheels on the ground) | Flatbed Towing (all four wheels suspended OFF the ground) | Front Wheels Raised, Rear Wheels on the Ground | Rear Wheels Raised, Front Wheels on the Ground |
|-------------------------|---|---|---|--|
| Two-Wheel Drive | NOT Permitted | Recommended Method | Shift lever must be In NEUTRAL, the speed less than 30 mph (48 km/h) and the distance traveled less than 15 mi (24 km). | May be used |
| Four-Wheel Drive | NOT Permitted | Recommended Method | NOT Permitted without a towing dolly | NOT Permitted without a towing dolly |

WHAT TO DO IN EMERGENCIES

FREEING A STUCK VEHICLE

- If your vehicle becomes stuck in mud, sand or snow, it can often be moved by a rocking motion. Turn your steering wheel right and left to clear the area around the front wheels. Then move the shift lever back and forth between REVERSE and 1st gear. Using minimal accelerator pedal pressure to maintain the rocking motion, without spinning the wheels, is most effective.
- Allow the engine to idle with the shift lever in NEUTRAL for at least one minute after every five rocking-motion cycles. This will minimize overheating and reduce the risk of transmission failure during prolonged efforts to free a stuck vehicle.

WARNING!

Fast spinning tires can be dangerous. Forces generated by excessive wheel speeds may cause tire damage or failure. A tire could explode and injure someone. Do not spin your vehicle's wheels faster than 30 mph (48 km/h) when you are stuck. Do not let anyone near a spinning wheel, no matter what the speed.

WARNING!

- Chains are not recommended for freeing a stuck vehicle. Chains may break, causing serious injury or death.
- Stand clear of vehicles when pulling with tow hooks. Tow straps and chains may break, causing serious injury.

CAUTION!

- When “rocking” a stuck vehicle by moving between 1st and REVERSE, do not spin the wheels faster than 15 mph (24 km/h), or drivetrain damage may result.
- Revving the engine or spinning the wheels too fast may lead to transmission overheating and failure. It can also damage the tires. Do not spin the wheels above 30 mph (48 km/h) while in gear (no transmission shifting occurring).

WHAT TO DO IN EMERGENCIES

EVENT DATA RECORDER (EDR)

- This vehicle is equipped with an event data recorder (EDR). The main purpose of an EDR is to record, in certain crash or near crash-like situations, such as an air bag deployment or hitting a road obstacle, data that will assist in understanding how a vehicle's systems performed. The EDR is designed to record data related to vehicle dynamics and safety systems for a short period of time, typically 30 seconds or less. The EDR in this vehicle is designed to record such data as:
 - How various systems in your vehicle were operating;
 - Whether or not the driver and passenger safety belts were buckled/fastened;
 - How far (if at all) the driver was depressing the accelerator and/or brake pedal; and,
 - How fast the vehicle was traveling.
- These data can help provide a better understanding of the circumstances in which crashes and injuries occur.

NOTE: EDR data are recorded by your vehicle only if a non-trivial crash situation occurs; no data are recorded by the EDR under normal driving conditions and no personal data (e.g. name, gender, age, and crash location) are recorded. However, other parties, such as law enforcement, could combine the EDR data with the type of personally identifying data routinely acquired during a crash investigation.

- To read data recorded by an EDR, special equipment is required, and access to the vehicle or the EDR is needed. In addition to the vehicle manufacturer, other parties such as law enforcement, that have the special equipment, can read the information if they have access to the vehicle or the EDR.

MAINTAINING YOUR VEHICLE

OPENING THE HOOD

- Pull the hood release lever located below the steering wheel at the base of the instrument panel.
- Reach into the opening beneath the center of the hood and move the safety latch lever while lifting the hood at the same time.

WARNING!

Be sure the hood is fully latched before driving your vehicle. If the hood is not fully latched, it could open when the vehicle is in motion and block your vision. Failure to follow this warning could result in serious injury or death.

MAINTAINING YOUR VEHICLE

ENGINE COMPARTMENT

3-7L Engine

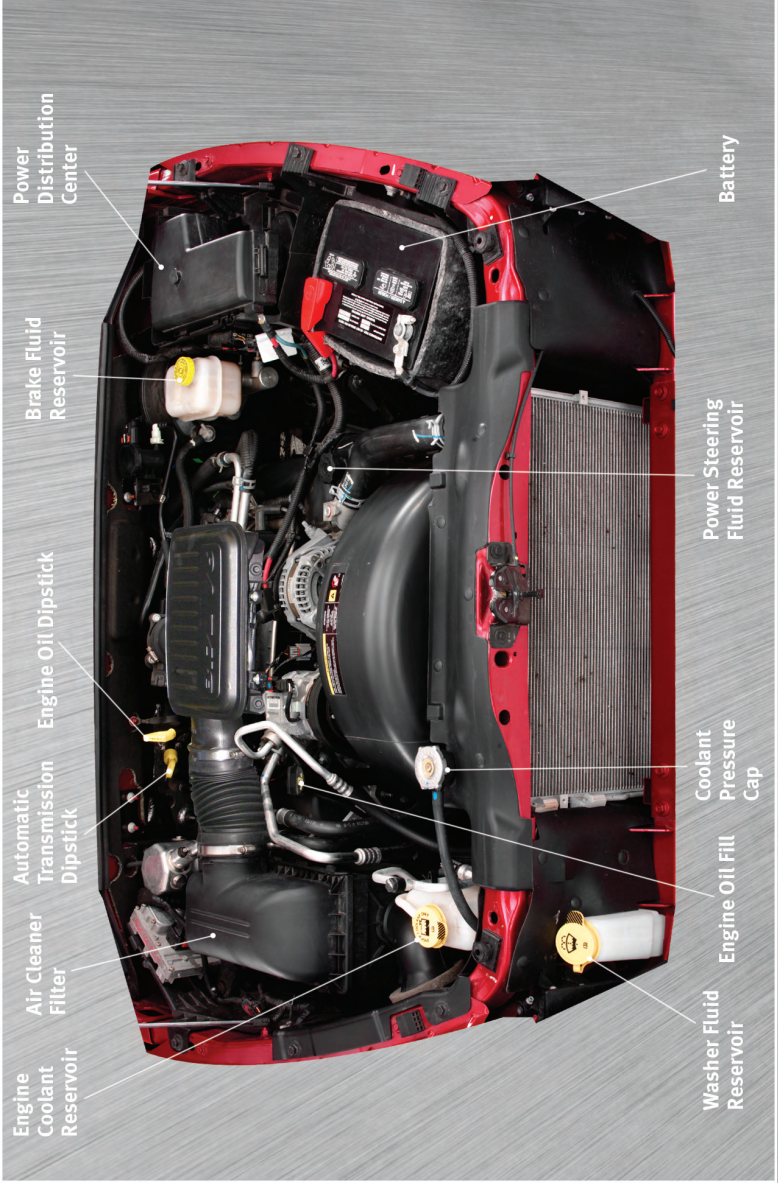

MAINTAINING YOUR VEHICLE

4-7L Engine

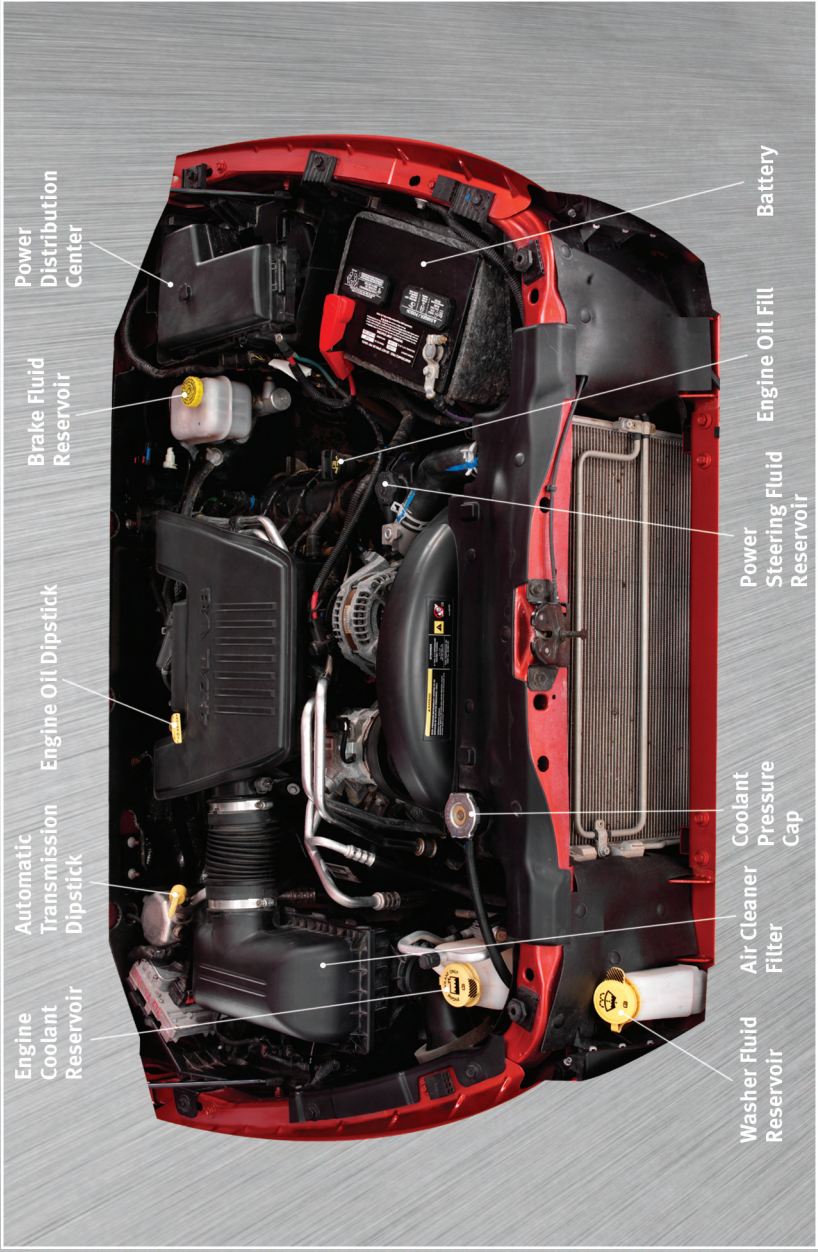

MAINTAINING YOUR VEHICLE

FLUIDS AND CAPACITIES

| Component | Fluid, Lubricant, or Genuine Part | Capacities |
|-----------------------------------|--|---|
| Engine Coolant 3.7L, 4.7L | MOPAR® Antifreeze/Coolant Five Year/100,000 Mile Formula HOAT (Hybrid Organic Additive Technology) or equivalent. | 13.3 Quarts (12.5 Liters) Includes heater and coolant recovery bottle filled to MAX level. |
| Engine Oil with Filter 3.7L, 4.7L | API certified 5W-20 engine oil, meeting the requirements of Chrysler Material Standard MS-6395. Refer to your oil filler cap for correct SAE grade. | 3.7L 5 Quarts (4.7 Liters) 4.7L 6 Quarts (5.7 Liters) |
| Fuel Selection 3.7L, 4.7L | 87 Octane | 22 Gallons (83 Liters) |
| Engine Oil Filter 3.7L, 4.7L | MOPAR® Engine Oil Filter or equivalent. | — |
| Spark Plug 3.7L | ZFR6F-11G (Gap 0.043 in [1.09 mm]) | — |
| Spark Plug 4.7L | Upper Bank — FR8TE2 (Gap 0.039 in [0.99 mm]) Lower Bank — FR8T1332 (Gap 0.051 in [1.30 mm]). | — |
| Automatic Transmission | MOPAR® ATF+4® Automatic Transmission Fluid or equivalent licensed ATF+4® product. | — |
| Transfer Case | MOPAR® ATF+4® Automatic Transmission Fluid or equivalent licensed ATF+4® product. | — |
| Front Axle | SAE 75W-90 Multi-Purpose Type, GL-5 Gear Lubricant MS-9763 or equivalent. | — |
| Rear Axle | SAE 75W-140 Synthetic Gear Lubricant MS-8985. Limited-slip rear axles require MOPAR® Limited-Slip Additive MS-10111 or equivalent. Whenever a fluid change is made, 4 oz (118 ml) should be added to the gear lubricant. | — |

MAINTAINING YOUR VEHICLE

| | | |
|--------------------------|---|---|
| Brake Master Cylinder | MOPAR [®] DOT 3 and SAE J1703 should be used or equivalent. If DOT 3 is not available, then DOT 4 is acceptable. Use only recommended Brake Fluids. | — |
| Power Steering Reservoir | MOPAR [®] Power Steering Fluid +4 or MOPAR [®] ATF+4 [®] Automatic Transmission Fluid or equivalent licensed ATF+4 [®] product. | — |

MAINTAINING YOUR VEHICLE

MAINTENANCE CHART

| Miles: | 6,000 | 12,000 | 18,000 | 24,000 | 30,000 | 36,000 | 42,000 | 48,000 | 54,000 | 60,000 | 66,000 | 72,000 | 78,000 |
|---|--------|--------|--------|--------|--------|--------|--------|--------|--------|---------|---------|---------|---------|
| Or Months: | 6 | 12 | 18 | 24 | 30 | 36 | 42 | 48 | 54 | 60 | 66 | 72 | 78 |
| Or Kilometers: | 10,000 | 20,000 | 30,000 | 40,000 | 50,000 | 60,000 | 70,000 | 80,000 | 90,000 | 100,000 | 110,000 | 120,000 | 130,000 |
| Change the engine oil and filter. | X | X | X | X | X | X | X | X | X | X | X | X | X |
| Rotate the tires. | X | X | X | X | X | X | X | X | X | X | X | X | X |
| If using your vehicle for any of the following: dusty or off-road conditions. Inspect the engine air cleaner filter; replace if necessary. | | X | | X | | X | | X | | | | X | |
| Inspect the brake linings; replace if necessary. | | X | | X | | X | | X | | X | | X | |
| Inspect the CV joints. Perform the first inspection at 12,000 miles (20,000 km) or 12 months. | | X | | X | | | | X | | | | X | |
| Inspect the exhaust system. Perform the first inspection at 12,000 miles (20,000 km) or 12 months. | | X | | X | | | | X | | | | X | |
| Inspect the front suspension, tie rod ends and boot seals for cracks or leaks and all parts for damage, wear, improper looseness or end play; replace if necessary. | | X | | X | | X | | X | | X | | X | |
| Replace the engine air cleaner filter. | | | | | X | | | | | X | | | |
| Inspect the transfer case fluid. | | | | | X | | | | | | | | |
| Inspect the front and rear axle fluid if using your vehicle for any of the following: police, taxi, off-road or frequent trailer towing. | | | X | | | X | | | X | | | X | |
| Change the automatic transmission fluid & filter(s) if using your vehicle for any of the following: police, taxi, fleet, or frequent trailer towing. | | | | | | | | | | X | | | |
| Replace the spark plugs (3.7L engines). | | | | | X | | | | | X | | | |
| Replace top row of spark plugs (4.7L engine). | | | | | | | | X | | | | | |
| Change the transfer case fluid if using your vehicle for any of the following: police, taxi, fleet, off-road, or frequent trailer towing. | | | | | | | | | | X | | | |

• Refer to the Owner's Manual on the DVD for the complete maintenance schedule.

MAINTAINING YOUR VEHICLE

Maintenance Record

| | Odometer | Date | Signature, Authorized Service Center |
|--|----------|------|--------------------------------------|
| 6,000 Miles (10,000 km) or 6 Months | | | |
| 12,000 Miles (20,000 km) or 12 Months | | | |
| 18,000 Miles (30,000 km) or 18 Months | | | |
| 24,000 Miles (40,000 km) or 24 Months | | | |
| 30,000 Miles (50,000 km) or 30 Months | | | |
| 36,000 Miles (60,000 km) or 36 Months | | | |
| 42,000 Miles (70,000 km) or 42 Months | | | |
| 48,000 Miles (80,000 km) or 48 Months | | | |
| 54,000 Miles (90,000 km) or 54 Months | | | |
| 60,000 Miles (100,000 km) or 60 Months | | | |
| 66,000 Miles (110,000 km) or 66 Months | | | |
| 72,000 Miles (120,000 km) or 72 Months | | | |
| 78,000 Miles (130,000 km) or 78 Months | | | |

MAINTAINING YOUR VEHICLE

FUSES

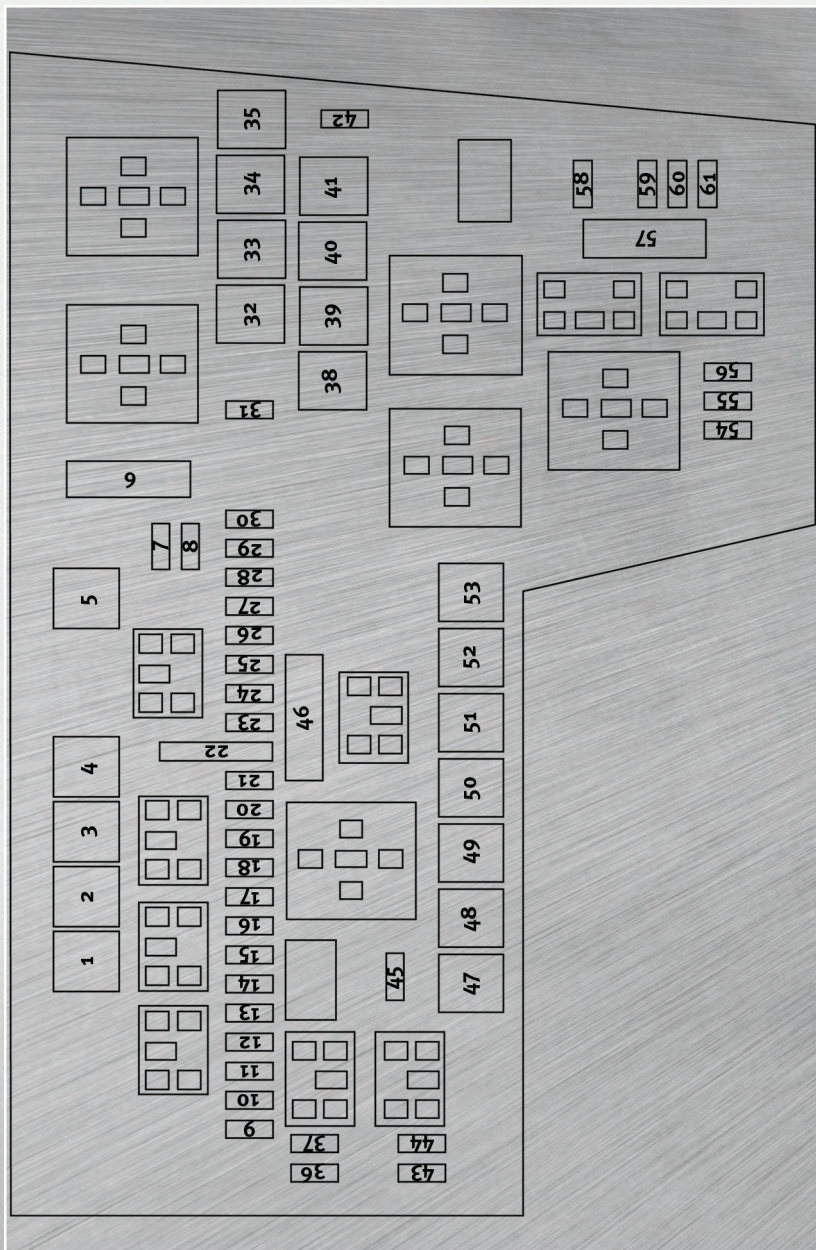

MAINTAINING YOUR VEHICLE

Power Distribution Center

- The Power Distribution Center located on the left side of the engine compartment. This center contains cartridge fuses, mini fuses and relays.

| Cavity | Cartridge Fuse | Mini-Fuse | Description |
|--------|----------------|----------------|---|
| 1 | — | — | Spare |
| 2 | — | — | Spare |
| 3 | 30 Amp Pink | | Electric Brake |
| 4 | 50 Amp Red | | Power Seat |
| 5 | — | — | Spare |
| 6 | | 20 Amp Yellow | Ignition Off Draw (IOD) Cabin Compartment Node (CCN), Radio |
| 7 | | 10 Amp Red | Powertrain Control Module (PCM)/Fuel/RAD/AC Coils |
| 8 | | 10 Amp Red | Cabin Compartment Node (CCN)/Mirror/4x4 |
| 9 | — | — | Spare |
| 10 | | 2 Amp Gray | Run/Start Ignition Switch |
| 11 | | 10 Amp Red | AC Clutch |
| 12 | | 15 Amp Blue | Trailer Tow Lt Stop/Turn |
| 13 | | 15 Amp Blue | Trailer Tow Rt Stop/Turn |
| 14 | | 20 Amp Yellow | Ignition Off Draw (IOD) #2 |
| 15 | | 25 Amp Natural | Trans/Powertrain Control Module (PCM) |
| 16 | | 20 Amp Yellow | Horn |
| 17 | | 20 Amp Yellow | ABS Feed (Valves) |
| 18 | | 20 Amp Yellow | Fuel Pump |
| 19 | | 15 Amp Blue | Center High-Mounted Stop Light (CHMSL) |
| 20 | | 20 Amp Yellow | Cabin Compartment Node (CCN) Door Locks/Brake Transmission Shift Interlock (BTSI) |
| 21 | | 25 Amp Natural | Audio Amp |
| 22 | | 20 Amp Yellow | Power Outlet (Switchable) |
| 23 | | 20 Amp Yellow | Fog Lamps |
| 24 | | 20 Amp Yellow | Powertrain Control Module (PCM) B+ |
| 25 | | 15 Amp Blue | Cabin Compartment Node (CCN) Illumination |
| 26 | | 20 Amp Yellow | Ignition Run/Start Feed |
| 27 | | 10 Amp Red | Power Mirror |
| 28 | | 20 Amp Yellow | Power Outlet |
| 29 | | 20 Amp Yellow | Front Control Module (FCM) 4 (Wipers) |
| 30 | — | — | Spare |
| 31 | | 30 Amp Green | Ignition Run/AC/Windows |

MAINTAINING YOUR VEHICLE

| Cavity | Cartridge Fuse | Mini-Fuse | Description |
|--------|----------------|----------------|--|
| 32 | 30 Amp Pink | | Front Control Module (FCM) 1 (Ext. Lights # 1) |
| 33 | 30 Amp Pink | | Auto Shut Down (ASD) |
| 34 | 30 Amp Pink | | Front Control Module (FCM) 2 (Ext. Light # 2) |
| 35 | 40 Amp Green | | HVAC Blower Motor |
| 36 | — | — | Spare |
| 37 | — | — | Spare |
| 38 | 20 Amp Blue | — | Spare |
| 39 | 30 Amp Pink | | Starter Solenoid |
| 40 | 40 Amp Green | | Ignition Run Feeds |
| 41 | 30 Amp Pink | | Wiper Motor |
| 42 | | 25 Amp Natural | Front Control Module (FCM) 5 (T-Case) |
| 43 | | 10 Amp Red | Lt Park Lamps |
| 44 | | 10 Amp Red | Rt Park Lamps |
| 45 | | 20 Amp Yellow | Trailer Tow Park Lamps |
| 46 | | 10 Amp Red | Airbag System # 2 |
| 47 | — | — | Spare |
| 48 | 20 Amp Blue | | Sunroof/Sound Box |
| 49 | 30 Amp Pink | | Trailer Tow B+ |
| 50 | 40 Amp Green | | Anti-Lock Brake System (ABS) Module (Pump) |
| 51 | 40 Amp Green | | Park Lamps |
| 52 | — | — | Spare |
| 53 | 40 Amp Green | | Rear Defogger |
| 54 | — | — | Spare |
| 55 | — | — | Spare |
| 56 | | 10 Amp Red | Heated Seats |
| 57 | | 20 Amp Yellow | Airbag System # 2 |
| 58 | | 20 Amp Yellow | Heated Seats |
| 59 | | 10 Amp Red | HVAC Module |
| 60 | | 10 Amp Red | ABS Module |
| 61 | | 20 Amp Yellow | Front Control Module (FCM) 3 (Reverse Lamps) |

MAINTAINING YOUR VEHICLE

TIRE PRESSURES

- Check the inflation pressure of each tire, including the spare tire, at least monthly and inflate to the recommended pressure for your vehicle.
- The tire pressures recommended for your vehicle are found on the “Tire and Loading Information” label located on the driver’s side door opening.

NOTE: Refer to the Owner’s Manual on the DVD for more information on the life of tires.

WARNING!

Overloading of your tires is dangerous. Overloading can cause tire failure, affect vehicle handling, and increase your stopping distance. Use tires of the recommended load capacity for your vehicle. Never overload them.

WARNING!

Improperly inflated tires are dangerous and can cause accidents. Under-inflation is the leading cause of tire failure and may result in severe cracking, component separation, or “blow out”. Over-inflation reduces a tire’s ability to cushion shock. Objects on the road and chuck holes can cause damage that results in tire failure. Unequal tire pressures can cause steering problems. You could lose control of your vehicle. Over-inflated or under-inflated tires can affect vehicle handling and can fail suddenly, resulting in loss of vehicle control.

WHEEL AND WHEEL TRIM CARE

- All wheels and wheel trim, especially aluminum and chrome plated wheels, should be cleaned regularly with a mild soap and water to prevent corrosion.
- To remove heavy soil and/or excessive brake dust, use MOPAR® Wheel Cleaner or equivalent or select a non-abrasive, non-acidic cleaner.

CAUTION!

Do not use scouring pads, steel wool, a bristle brush, or metal polishes. Do not use oven cleaner. These products may damage the wheel’s protective finish. Avoid automatic car washes that use acidic solutions or harsh brushes that may damage the wheel’s protective finish. Only MOPAR® Wheel Cleaner or equivalent is recommended.

MAINTAINING YOUR VEHICLE

EXTERIOR BULBS

| LIGHT BULBS – Exterior | Bulb Number |
|---------------------------------------|--------------------|
| Backup, Tail, Stop, Turn Lamp | 3057 |
| Center High-Mounted Stop Lamp (CHMSL) | 921 |
| Fog Lamp - If Equipped | PSX24W |
| Front Park/Turn Signal | 3157NA |
| Front Side Marker | 3157NA |
| Headlamp | H13 |
| License Lamp | 168 |
| Cargo Lamp | 921 |

CONSUMER ASSISTANCE

CHRYSLER GROUP LLC CUSTOMER CENTER

P.O. Box 21-8004

Auburn Hills, MI 48321-8004

Phone: 1-866-726-4636

CHRYSLER CANADA INC. CUSTOMER CENTER

P.O. Box 1621

Windsor, Ontario N9A 4H6

Phone: 1-800-465-2001

ASSISTANCE FOR THE HEARING IMPAIRED

- To assist customers who have hearing difficulties, the manufacturer has installed special TDD (Telecommunication Devices for the Deaf) equipment at its customer center. Any hearing or speech impaired customer, who has access to a TDD or a conventional teletypewriter (TTY) in the United States, can communicate with the manufacturer by dialing 1-800-380-CHRY. Canadian residents with hearing difficulties that require assistance can use the special needs relay service offered by Bell Canada. For TTY teletypewriter users, dial 711 and for Voice callers, dial 1-800-855-0511 to connect with a Bell Relay Service operator.

WARNING!

Engine exhaust, some of its constituents, and certain vehicle components contain, or emit, chemicals known to the State of California to cause cancer and birth defects, or other reproductive harm. In addition, certain fluids contained in vehicles and certain products of component wear contain, or emit, chemicals known to the State of California to cause cancer and birth defects, or other reproductive harm.

PUBLICATIONS ORDERING

- **If you are the first registered retail owner of your vehicle**, you may obtain one free printed copy of the Owner's Manual, Warranty Booklet or Radio Manuals on your DVD by calling 1-877-726-4636 (U.S.) or 1-800-387-1143 (Canada) or by contacting your dealer.
- Replacement User Guides or DVDs or, if you prefer, additional printed copies of the Owner's Manual, Warranty Booklet or Radio Manuals may be purchased by visiting www.techauthority.com or by calling 1-800-890-4038 (U.S.) or 1-800-387-1143 (Canada). Visa, Master Card, American Express and Discover orders are accepted. If you prefer mailing your order, please call the above numbers for an order form.

NOTE: A street address is required when ordering manuals (no P.O. Boxes).

CONSUMER ASSISTANCE

NOTE:

- The Owner's Manual and User Guide electronic files are also available on the Chrysler, Jeep and Dodge websites.
- Click on the "For Owners" tab, select "Owner/Service Manuals", then select your desired model year and vehicle from the drop down lists.

REPORTING SAFETY DEFECTS IN THE 50 UNITED STATES AND WASHINGTON, D.C.

- If you believe that your vehicle has a defect that could cause a crash or cause injury or death, you should immediately inform the National Highway Traffic Safety Administration (NHTSA) in addition to notifying the manufacturer.
- If NHTSA receives similar complaints, it may open an investigation, and if it finds that a safety defect exists in a group of vehicles, it may order a recall and remedy campaign. However, NHTSA cannot become involved in individual problems between you, your authorized dealer, and the manufacturer.
- To contact NHTSA, you may either call the Auto Safety Hotline toll free at 1-888-327-4236 (TTY: 1-800-424-9153), or go to <http://www.safercar.gov>; or write to: Administrator, NHTSA, 1200 New Jersey Avenue, SE., West Building, Washington, D.C. 20590. You can also obtain other information about motor vehicle safety from <http://www.safercar.gov>.

In Canada

- If you believe that your vehicle has a safety defect, you should contact the Customer Service Department immediately. Canadian customers who wish to report a safety defect to the Canadian government should write to: Transport Canada, Motor Vehicle Defect Investigations and Recalls, 2780 Sheffield Road, Ottawa, Ontario K1B 3V9.

TIRE WARRANTY

Tire Limited Warranty And Adjustment Policy

- When a tire is removed from service due to a covered warranty condition under a tire manufacturer's "Limited Warranty Program", you may be eligible for a free tire replacement or a comparable new tire on a "prorated basis".
- Certain conditions, such as irregular wear or tire damage due to road hazards, collision, improper inflation, intentional alteration, and misuse, are excluded from the Limited Warranty Program. The Limited Warranty Program expires when your tires either wear to a specified tread depth, and/or after a period of time from the date of purchase, as stated in the Tire Warranty on the DVD.

NOTE: Refer to the Tire Warranty on the DVD for specific information relating to the manufacturer's limited warranty for the tires installed on your vehicle. If you have any questions regarding the limited tire warranty coverage, contact your local authorized dealer or your local authorized tire dealer.

CONSUMER ASSISTANCE

Disclaimer:

- THE TIRE MANUFACTURER'S LIMITED WARRANTY PROGRAM, THE DETAILS OF WHICH CAN BE FOUND ON THE OWNERS MANUAL DVD, THE TIRE MANUFACTURER'S WEBSITE OR AT ANY AUTHORIZED SERVICE CENTER ARE IN LIEU OF ALL OTHER REMEDIES OR WARRANTIES, EXPRESS OR IMPLIED, ARISING BY LAW OR OTHERWISE, INCLUDING FITNESS FOR A PARTICULAR PURPOSE OR MERCHANTABILITY. THE TIRE MANUFACTURER EXPRESSLY DISCLAIMS LIABILITY FOR INDIRECT, SPECIAL, INCIDENTAL OR CONSEQUENTIAL DAMAGES, LOST PROFIT, LOSS OF BUSINESS, LOSS OF GOODWILL, LOSS OF REPUTATION, PUNITIVE OR ANY OTHER DAMAGE, COST OR LOSS OF ANY KIND. SOME STATES AND PROVINCES DO NOT ALLOW THE EXCLUSION OR LIMITATION OF INCIDENTAL OR CONSEQUENTIAL DAMAGES, SO THE ABOVE LIMITATION OR EXCLUSION MAY NOT APPLY TO YOU.

WARNING!

NOTE: Refer to the Owner's Manual on the DVD for complete warning information that could prevent accidents, injuries and even deaths.

WARNING!

Death, serious injury and/or property damage may result from:

- Tire failure due to impact damage and/or improper maintenance.

(Continued)

WARNING! (Continued)

- Tires should be inspected regularly by a qualified technician for signs of damage, such as punctures, impacts, under-inflation or overloading.
- Progressive air loss may result from punctures, cuts, curbing, impacts or partial bead unseating.

Some fitment causes for air loss are:

- Incomplete bead seating.
- Bead tearing caused by a machine tool due to insufficient lubrication or improper adjustment.
- Leaking valve core or rubber valve components (these should be replaced when problems are detected and whenever tires are replaced).
- Tire failure due to improper repairs.
- See Rubber Manufacturer's Association (RMA) established repair procedures at www.rma.org for information on proper repair procedures. Never perform a temporary repair or use an inner tube as a substitute for a proper repair. Only qualified persons should repair tires.
- Explosion of tire/rim assembly due to improper mounting.
- Only specially trained persons should mount tires.
- Failure to mount tires on approved rims.
- Failure to deflate single or dual assemblies completely before demounting.

CONSUMER ASSISTANCE

Using Lift Kits

- Use of lift kits with some vehicle/tire combinations can cause instability or loss of control. When changing tire sizes, always consult an installer for optimum rim width and carefully check vehicle/tire clearances.

Check Your Tires For Damage

- Frequent (at least monthly) inspection of your tires for signs of damage, uneven tread wear and their general condition is important for safety. Impacts, penetrations, cracks, knots, bulges or air loss always require tire removal and expert inspection.

Tire Service Life

- The service life of a tire is dependent upon varying factors including, but not limited to, your driving style, tire pressure and distance driven.

WARNING!

Tires and the spare tire should be replaced after six years, regardless of the remaining tread. Failure to follow this warning can result in sudden tire failure. You could lose control and have an accident resulting in serious injury or death.

- Keep dismantled tires in a cool, dry place with as little exposure to the light as possible.
- Protect tires from contact with oil, grease, and gasoline.

NOTE: All tire warranties are made by the tire manufacturer. Tires are not covered under your Chrysler New Vehicle Limited Warranty.

MOPAR ACCESSORIES

MOPAR® ACCESSORIES

- The following highlights just some of the authentic Dodge Truck Accessories by MOPAR® that have been engineered to customize your Dodge Dakota.
- To see the full line of accessories, stop by your Dodge dealer or visit MOPAR.com.

CHROME:

- Exhaust Tip
- Tubular Side Steps
- Fuel Filler Door
- 18" chrome Cast Aluminum Wheel
- Front Air Deflector
- Grille

EXTERIOR:

- Under The Rail Bedliner
- Side Window Air Deflectors
- Fender Flares
- Fiberglass Tonneau Cover
- Bed Extender
- Bed Mat
- Snapless Tonneau Cover
- Tri-Fold Tonneau Cover
- Tuner Style Tail lamps
- Molded Splash Guards
- Hitch Receiver

INTERIOR:

- Premium Carpet Floor Mats
- Door Sill Guards
- Slush Mats

ELECTRONICS:

- Portable Navigation Systems
- Uconnect™ Web (WiFi)
- Sirius Satellite Radio
- iPod® Adapter
- Media Center 730N (RER Navigation Radio)

CARRIERS:

- Bed Mounted Bike Carrier
- Bed Mounted Cargo Basket With Cargo Net
- Roof Mount Bike Carrier
- Bed Mounted Ski and Snowboard Carrier
- Sport Utility Bars (accommodates all carriers)
- Diamond Plate Toolbox

iPod® is a registered trademark of Apple, Inc.

NOTES

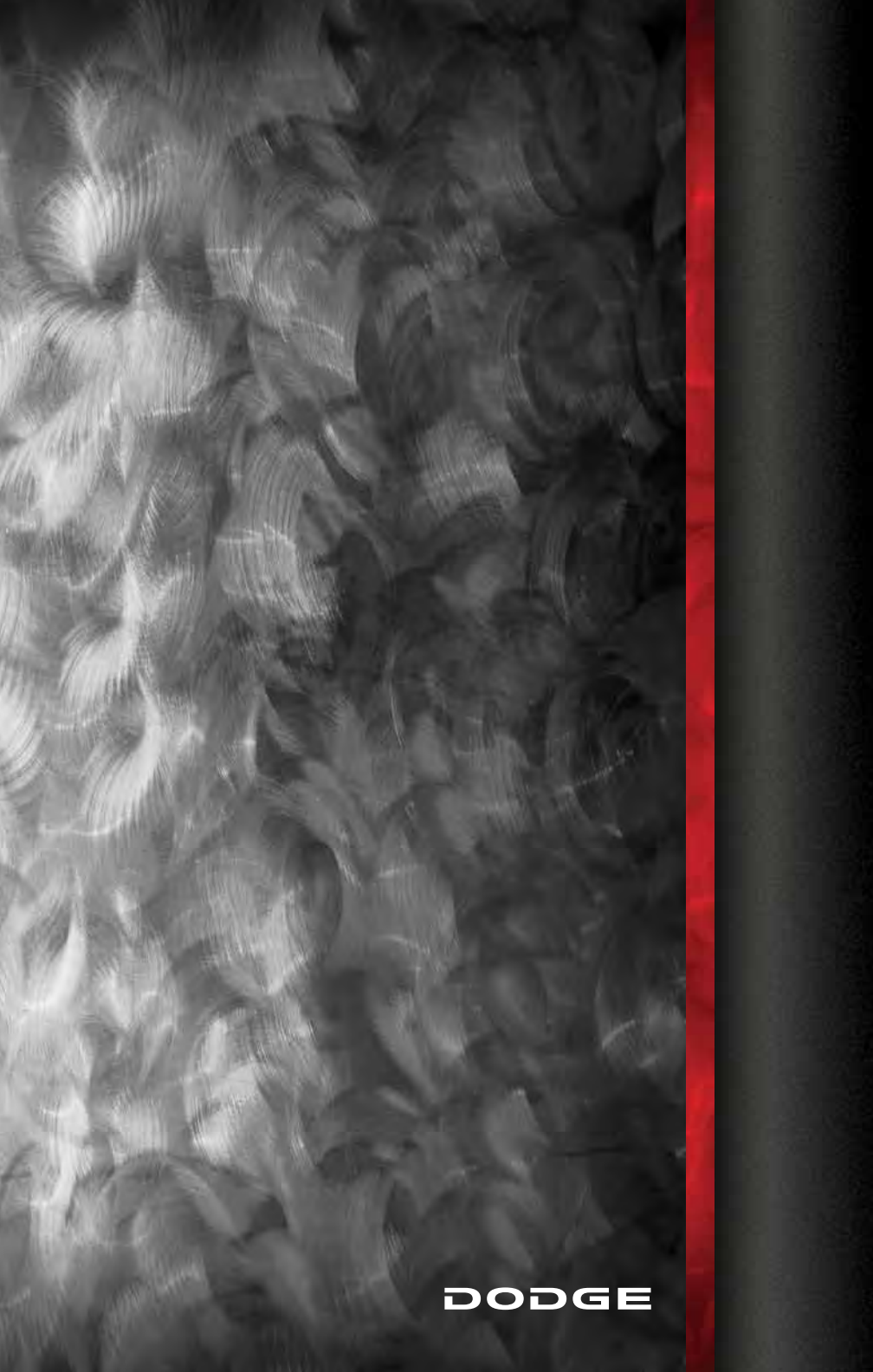

DODGE

DAKOTA

DODGE.com

This guide has been prepared to help you get quickly acquainted with your new Dodge and to provide a convenient reference source for common questions. However, it is not a substitute for your Owner's Manual.

For complete operational instructions, maintenance procedures and important safety messages, please consult your Owner's Manual, Navigation/Media Center Manuals, Multimedia User Manual and other Warning Labels in your vehicle.

Not all features shown in this guide may apply to your vehicle. For additional information on accessories to help personalize your vehicle, visit www.mopar.com or your local Dodge dealer.



10ND33-926-AA
Dakota
Third Printing
User Guide