

Table of contents

Introduction	2
Diesel information	4
Warning lights	7
Starting	9
Driving tips	14
General maintenance information	19
Scheduled maintenance	32
Minor troubleshooting guide	33
Capacities and specifications	36
Service points	38

All rights reserved. Reproduction by any means, electronic or mechanical including photocopying, recording or by any information storage and retrieval system or translation in whole or part is not permitted without written authorization from Ford Motor Company.

Copyright © 1999 Ford Motor Company

Introduction

The following warning may be required by California law:



California Proposition 65 Warning: Diesel engine exhaust, some of its constituents, and certain vehicle components contain or may emit chemicals known to the State of California to cause cancer or birth defects or other reproductive harm.

Your new diesel engine will feel, drive and function somewhat differently than a gasoline engine. Therefore it is very important that you read and thoroughly familiarize yourself and others operating the vehicle with this guide.

This guide will acquaint you with the Power Stroke (7.3L DIT) diesel engine. It provides recommendations on engine care and operating procedures. For complete vehicle information, also refer to the Owner Guide included with the vehicle. It also describes equipment and gives specifications for equipment that was in effect when this guide was approved for printing, and should be considered a permanent part of the vehicle.

Ford may discontinue models or change specifications without any notice and without incurring obligations.

IMPORTANT NOTICE

Ford vehicles are suitable for producing ambulances only if equipped with the *Ford Ambulance Preparation Package*. In addition, Ford urges ambulance manufacturers to follow the recommendation of the *Ford Incomplete Vehicle Manual*, *Ford Truck Body Builder's Layout Book* (and pertinent supplements) and the "Qualified Vehicle Modifiers Guidelines." Using a Ford vehicle without the *Ford Ambulance Preparation Package* to produce an ambulance voids the Ford warranty and could result in elevated underbody temperatures, fuel overpressurization and the risk of fuel expulsion and fires. To determine whether the vehicle is equipped with the *Ford Ambulance Preparation Package*, inspect the information plate on the driver's side door pillar. Contact the manufacturer of your vehicle to determine whether the ambulance manufacturer's followed Ford's recommendations.

WARNINGS

Throughout this guide, you will find warnings. Warnings remind you to be especially careful to avoid personal injury.

NEW VEHICLE BREAK-IN

Your vehicle does not need an extensive break-in. Try not to drive continuously at the same speed for the first 1 600 km (1 000 miles) of new vehicle operation. Vary your speed to allow parts to adjust themselves to other parts.

Drive your new vehicle at least 800 km (500 miles) before towing a trailer.

Do not add friction modifier compounds or special break-in oils during the first few thousand kilometers (miles) of operation, since these additives may prevent piston ring seating. See “Engine oil” in the *General Maintenance Information* chapter for more information on oil usage.

Diesel information

DIESEL ENGINE INFORMATION

The diesel engine fuel system consists of:

- a frame-mounted electric fuel supply pump
- an engine mounted fuel filter/water separator
- a fuel restriction sensor
- a unit injector for each cylinder

The combination fuel filter/water separator removes both water and impurities from the fuel. The filter should be changed at the recommended service interval. Refer to the “Service Guide” for more information. The filter bowl should be drained at regular intervals or when the “WATER IN FUEL” light illuminates in the instrument cluster.

The fuel injectors are located in the center of the combustion chambers in the cylinder head between the rocker arm assemblies. The glow plug system and fuel injection system are controlled through the powertrain control module (PCM).

Fuel is drawn from the fuel tank by a frame-mounted electric fuel pump. The fuel pump provides pressurized fuel to the engine and is electronically controlled by the fuel pump PCM relay. The fuel pump contains a pressure relief valve for overpressure protection in the event of restricted flow.

Lubrication system

It is important to change the engine oil at the recommended service intervals, because oil viscosity is important in maintaining the oil pressure required to actuate the fuel injectors. Extended oil change intervals can negatively affect engine performance and fuel economy.

The turbocharger, which is supplied pressurized oil, is also used to actuate an exhaust backpressure warm-up system (if equipped). Pressurized oil returning to the turbocharger is routed to the exhaust backpressure actuator. During exhaust backpressure operation, the engine’s sound will be altered and you may notice a change in engine performance while it’s engaged. This function occurs only during cold weather warm-up cycle.

Fast start glow plug system

The glow plug system consists of:

- eight glow plugs
- the glow plug relay
- engine oil temperature (EOT) sensor
- barometric pressure (BARO) sensor

The glow plug system is electronically controlled by the PCM. The PCM energizes the glow plugs immediately after the ignition is placed in the ON position, then determines how long the glow plugs will be on according to the EOT and BARO sensors. The required time for the glow plugs to be energized decreases as the engine oil temperature and barometric pressure increase.

Engine cooling system

The cooling system contains an engine oil cooler which is mounted to the side of the cylinder block. The cooler's function is to regulate engine oil temperature.

Engine governed speed

The engine governor is controlled by the PCM. The PCM controls fuel input to limit maximum engine speed. It will not, however, prevent engine overspeeding resulting from downshifting at high vehicle speed or by descending steep grades at too high a vehicle speed for the selected transmission gear.

For maximum vehicle speed in various gears, refer to the "Transmission shift speed" chart in the *Driving tips* chapter. Do not exceed 3,600 rpm. Maximum engine governed speed is 3,000–4,000 rpm depending on engine load. Excessive rpm can only be achieved by manually downshifting at too high of a vehicle speed.

Operating the engine beyond the governed speed can cause severe engine damage.

Diesel information

Air filter restriction gauge

The restriction gauge, located on the clean-air side of the air cleaner upper housing, shows if the air filter is clogged. Refer to “Engine Compartment” in *Service Points* chapter.

The air filter element should be replaced when the yellow band on the gauge reaches the CHANGE FILTER mark. Engine performance and fuel economy are adversely affected when maximum restriction is reached. After servicing the air filter element, reset the restriction gauge by pressing the button the end of the gauge.

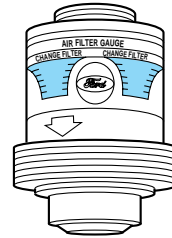
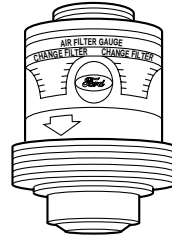

Warning lights

ECONOLINE

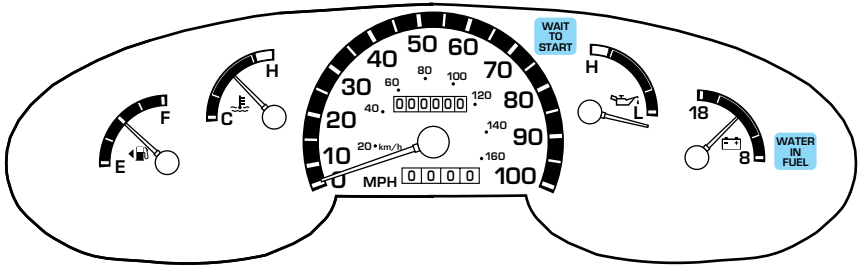

F-250/350, EXCURSION

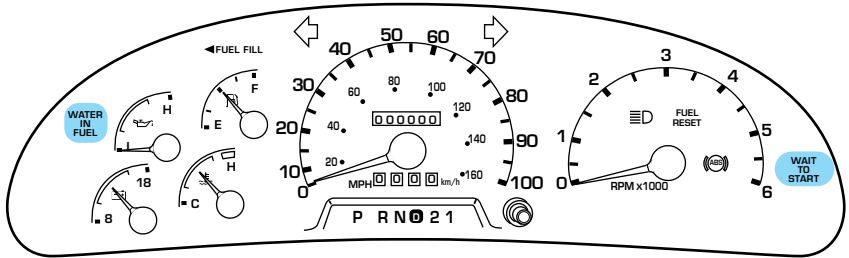

F-450/550

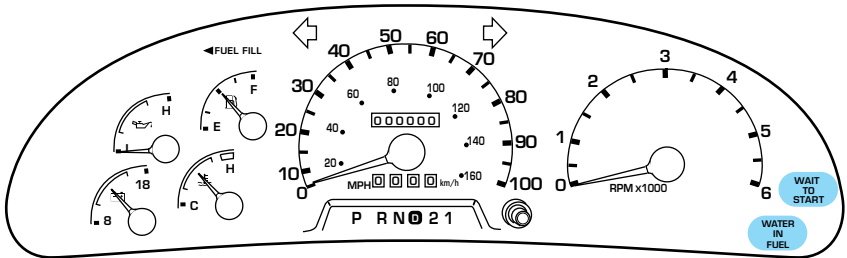

Warning lights

WAIT TO START

With the key in the ON position, the WAIT TO START light will illuminate if glow plug heat is necessary as a starting aid. Wait until the light goes off before starting. The light should always illuminate briefly, when the ignition key is in the ON position. If the light does not illuminate, there may be a problem. Refer to the *Starting* chapter in this guide. After the engine starts, the light should remain off.

The light should always illuminate at least momentarily when the engine is cold and the ignition is turned to ON. If it does not illuminate, the glow plug system should be checked and repaired promptly to avoid difficulty in cold starting.

**WAIT
TO
START**

WATER IN FUEL

During refueling, it is possible for water-contaminated diesel fuel to be pumped into your tank. Your vehicle fuel system is equipped with a fuel filter/water separator to remove water from the fuel. The WATER IN FUEL light will illuminate when the ignition is turned to START (as part of the light function check) and when the fuel filter/water separator has a significant quantity of water in it.

If the light illuminates when the engine is running, stop the vehicle as soon as safely possible, shut off the engine, then drain the filter bowl. Refer to the *General maintenance* chapter for drain procedure. Allowing water to stay in the system could result in extensive damage to, or failure of, the fuel injection system.

**WATER
IN
FUEL**



Do not drain the water separator while the engine is running. Fuel may ignite if the separator is drained while the engine is running or the vehicle is moving.

STARTING THE ENGINE

Read all starting instructions carefully before you start your vehicle. Starting procedures are also shown on the vehicle visor. For temperatures below 0°C (32°F), the use of the correct grade engine oil is essential for proper operation.

If your vehicle is equipped with a manual transmission, make sure the parking brake is set fully before you turn the key. Depress the clutch pedal and place the gearshift in the neutral position. The clutch must be fully depressed in order to operate the starter. Do not press the accelerator during starting.

If your vehicle is equipped with an automatic transmission, ensure the gearshift lever is in P (Park) and the parking brake is set before you turn the key. Do not press the accelerator during starting.

COLD WEATHER STARTING

Do not crank the engine for more than 30 seconds at a time as starter damage may occur. If the engine fails to start, turn the key to OFF and wait 30 seconds before trying again.

Do not use starting fluid such as ether in the air intake system (see Air Cleaner Decal). Such fluid could cause immediate explosive damage to the engine and possible personal injury.

Do not add gasoline, gasohol or alcohol to diesel fuel. This practice creates a serious fire hazard and causes engine performance problems.

1. Make sure all vehicle occupants have buckled their safety belts. For more information on safety belts and their proper usage, refer to *Seating and safety restraints* chapter in the owner guide.

2. Make sure the headlamps and vehicle accessories are off.

3. Turn the key to the ON position.

When the WAIT TO START light goes off, turn the key to START.

(For Canadian vehicles, the daytime running lamps will be on if the

parking brake is not applied and the key is turned to ON.)

4. When the engine starts, release the key. The glow plugs will continue to be activated for up to two minutes. If the engine is not started before the activation ceases, the glow plug system must be reset by turning the ignition key to OFF.

**WAIT
TO
START**

Starting

5. After the engine starts, allow it to idle for about 15 seconds. (Do not increase engine speed until the oil pressure gauge indicates normal pressure.)

STOPPING THE ENGINE

Turn the ignition to OFF. To prolong engine life (after extended high speed or maximum GVW operation), it is recommended that a hot engine be allowed to operate at low idle for about 7–10 minutes which would allow sufficient time for the turbocharged engine to cool down.

COLD WEATHER OPERATION

Changing to a lighter grade engine oil also makes starting easier under these conditions. Refer to “Engine Oil Specifications” in the *General maintenance information* chapter.

At temperatures below -7°C (20°F), Number 2–D diesel fuel may thicken enough to clog the fuel filter. Your engine is equipped with a fuel filter/heater/water/separator to keep the wax melted which will help prevent fuel filter clogging. However, if the engine starts but stalls after a short time and will not restart, the fuel filter may be clogged. For best results in cold weather, use Number 1–D diesel fuel or “winterized” Number 2–D diesel fuel which has an additive to minimize wax formation.

Your vehicle is also equipped with a bypass relief valve, located on the in-tank fuel sending unit, which provides fuel flow to the engine if the fuel pickup should become plugged by ice or wax. To allow this bypass valve to function and avoid engine fuel starvation, it is recommended that, during cold weather operation 0°C (32°F) or below, the fuel level in your tank should not be allowed to drop below 1/4 full. This will help prevent air from entering the fuel system and stalling the engine.

In cold weather below 0°C (32°F) your diesel engine will slowly increase to a higher idle speed if left idling in P (Park). The sound of the engine may change also, as an exhaust device engages to improve heater performance and reduce exhaust smoke.

Operation in snow

Vehicle operation in heavy snowfall or in dry loose snow that may swirl around the front of the vehicle may feed excessive amounts of snow into the air intake system. This could plug the air cleaner with snow and cause the engine to stall.

Operation in standing water

Ingestion of water into the diesel engine can result in immediate and severe damage to the engine. If driving through water, slow down to avoid splashing water into the intake. If the engine stalls, and ingestion of water into the engine is suspected, do not try to restart the engine. Consult your dealer for service immediately. Follow the cylinder compression test procedure outlined in the Workshop Manual, then check the engine oil for contamination.

Engine block heater (if equipped)

Refer to the *Starting* chapter in your Owner Guide.

JUMP STARTING YOUR VEHICLE



The gases around the battery can explode if exposed to flames, sparks, or lit cigarettes. An explosion could result in injury or vehicle damage.



Do not push start your vehicle. You could damage the catalytic converter.



Batteries contain sulfuric acid which burns skin, eyes, and clothing.

Preparing your vehicle

Also see the label on the battery.

1. Use only a 12-volt supply to start your vehicle. If you connect your battery to a 24-volt power supply you can damage your starter, ignition system and other electrical components. Do not attach the jumper cables to the glow plug relay as this could severely damage the glow plugs, injector driver module and PCM.
2. Do not disconnect the battery of the disabled vehicle as this could damage the vehicle's electrical system.
3. Park the booster vehicle close to the hood of the disabled vehicle making sure they **do not** touch. Set the parking brake on both vehicles and stay clear of the engine cooling fan and other moving parts.

Starting

4. Check all battery terminals and remove any excessive corrosion before you attach the battery cables.
5. Turn the heater fan on in both vehicles to protect any electrical surges. Turn all other accessories off.

Connecting the jumper cables

1. Position the vehicles so that they do not touch one another.
2. Switch off the engine. Switch off any unnecessary electrical equipment.
3. Connect the positive (+) terminal of the discharged battery to the positive (+) terminal of the booster battery. **Do not** jump start the driver's side or frame mounted battery.
4. Connect one end of the second lead to the negative (-) terminal of the booster battery and the other end to a metal part of the engine to be started, not to the negative (-) terminal of the discharged battery.
5. Make sure that the jump leads are clear of moving parts of the engine.

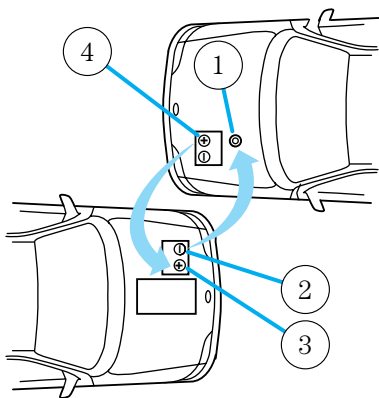

Do not connect the end of the second cable to the negative (-) terminal of the battery to be jumped. A spark may cause an explosion of the gases that surround the battery.

Jump starting

1. Start the booster vehicle and run the engine at moderately increased speed.
2. Start the engine of the vehicle with the discharged battery.
3. Once the engine has been started, run both vehicles for a further three minutes before disconnecting the leads.

Removing the jumper cables

1. Remove the jumper cables in reverse order. Take the cable off the metallic surface first, followed by the cable on the negative (-) booster battery terminal.
2. Remove the cable from the positive (+) terminal of the booster battery and then the discharged battery.
3. After the disabled vehicle has been started, allow it to idle for a while so the engine can “relearn” its idle conditions.

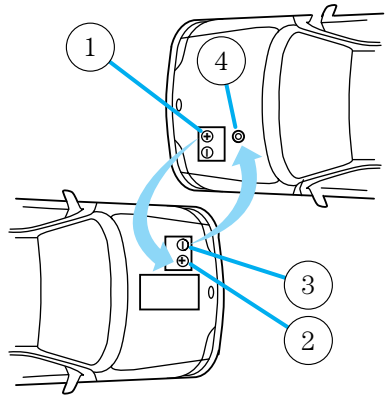

Driving tips

TRANSMISSION SHIFT SPEEDS

Do not overspeed the engine when going downhill or steep grades. If equipped, use the tachometer and do not allow engine speed to exceed the redline area. Operating the engine beyond the recommended speeds can cause severe engine damage.

Upshift and downshift according to the following shift speed charts:

Upshifts when accelerating (recommended for best fuel economy)		
6-speed transmission		
Shift from:	Transfer case position ¹ (if equipped)	
	2H or 4H	4L
LO-1	8 km/h (5 mph)	3 km/h (2 mph)
1-2	16 km/h (10 mph)	6 km/h (4 mph)
2-3	32 km/h (20 mph)	13 km/h (8 mph)
3-4	48 km/h (30 mph)	19 km/h (12 mph)
4 - D (Overdrive)	64 km/h (40 mph)	24 km/h (15 mph)

Maximum downshift speeds¹		
6-speed transmission		
Shift from:	Transfer case position (if equipped) ²	
	2H or 4H	4L
D (Overdrive) - 4	72 km/h (45 mph)	26 km/h (16 mph)
4-3	56 km/h (35 mph)	19 km/h (12 mph)
3-2	32 km/h (20 mph)	13 km/h (8 mph)
2-1	8 km/h (5 mph)	3 km/h (2 mph)
1-LO	Only shift to LO when at a stop.	
¹ Use 2H or 4H for 4WD equipped vehicles.		
² Downshift at lower speeds when driving on slippery surfaces.		

TRAILER TOWING

Refer to your "Owner Guide" for full details on towing a trailer.

Econoline trailer towing tables

Your vehicle may tow a class I, II or III trailer provided the maximum trailer weight is less than or equal to the maximum trailer weight listed for your engine and rear axle ratio on the following charts.

GCWR (Gross Combined Weight Rating)/Trailer Weights			
Rear axle ratio	Maximum GCWR-kg (lbs.)	Trailer weight range-kg (lbs.) (0-Maximum)	Maximum Frontal Area Of Trailer-m² (ft²)
Regular Van E-350			
3.55	7 258 (16 000)	4 536 (10 000)	5.52 (60)
4.10	9 072 (20 000)	4 536 (10 000)	5.52 (60)
Super Van E-350			
3.55	7 258 (16 000)	4 445 (9 800)	5.52 (60)
4.10	9 072 (20 000)	4 536 (10 000)	5.52 (60)
Club Wagon Regular E-350 (12 passenger)			
3.55	7 258 (16 000)	4 309 (9 500)	5.52 (60)
4.10	9 072 (20 000)	4 536 (10 000)	5.52 (60)
Club Wagon Super E-350 (15 passenger)			
3.55	7 258 (16 000)	4 173 (9 200)	5.52 (60)
4.10	9 072 (20 000)	4 536 (10 000)	5.52 (60)
E-350 RV Cutaway (single rear wheel)			
4.10	9 072 (20 000)	4 717 (10 400)*	5.52 (60)
E-350 RV Cutaway (dual rear wheel)			
4.10	9 072 (20 000)	4 309 (9 500)	5.52 (60)
E-350 Commercial Cutaway (single rear wheel)			
4.10	9 072 (20 000)	4 717 (10 400)*	5.52 (60)
E-350 Commercial Cutaway (dual rear wheel)			
4.10	9 072 (20 000)	4 400 (9 700)	5.52 (60)
<p>Maximum loaded trailer weight of 4 717 kg (10 400 lbs.) on 7.3L E350 RV and commercial cutaways (single rear wheel) applicable to fifth wheel trailer usage only. Otherwise, maximum trailer weight is 4 717 kg (10 000 lbs.).</p> <p>For high altitude operation reduce GCWR by 2% per 300 meters (1 000 ft) elevation.</p> <p>To determine the maximum trailer weight designed for you particular vehicle as equipped, follow the section <i>Calculating the load your vehicle can tow/carry</i> earlier in this chapter.</p>			

Driving tips

Your vehicle's load capacity is designated by weight, not by volume, so you cannot necessarily use all available space when loading a vehicle.

Distribute the load so that only 10 to 15% of the total is on the tongue. Tie down the load so that it does not shift and change the weight on the hitch.

Towing a trailer places an additional load on your vehicle's engine, transmission, axle, brakes, tires and suspension. Inspect these components carefully after any towing operation.



Do not exceed the GVWR or the GAWR specified on the certification label.



Towing trailers beyond the maximum recommended gross trailer weight could result in engine damage, transmission/axle damage, structural damage, loss of control, and personal injury.

F-Series and Excursion trailer towing tables

GCWR (Gross Combined Weight Rating)/Trailer Weights			
Model	Rear axle ratio	Maximum GCWR-kg (lbs.)	Maximum trailer weight-kg (lbs.)¹
F-250 and Excursion	3.73	9 072 (20 000)	4 536 (10 000)
F-250	4.10	9 072 (20 000)	4 536 (10 000)
F-350	3.73	9 072 (20 000)	4 536 (10 000)
F-350 (DRW)	4.10	9 072 (20 000)	4 536 (10 000)
F-450	4.88	11 794 (26 000)	4 536 (10 000)
F-550 (17 500 GVW)	4.88	11 794 (26 000)	4 536 (10 000)
F-550 (19 000 GVW)	4.88	11 794 (26 000)	4 536 (10 000)

¹ Conventional/Class IV trailer hitch only. Fifth wheel trailer maximum weights can be calculated by subtracting the GVW from the GCWR.

AUXILIARY POWERTRAIN CONTROL MODULE (APCM) (IF EQUIPPED)

Your vehicle may be equipped with an auxiliary PCM. It has the following features:

RPM control

This feature is used for elevating the engine's idle speed. Using this feature is the recommended method of elevating idle speed for PTO applications.

- Rpm control can be activated from inside the vehicle and can be programmed to activate automatically upon engine start-up.
- Programmable speed presets range from 1300–2500 rpm.

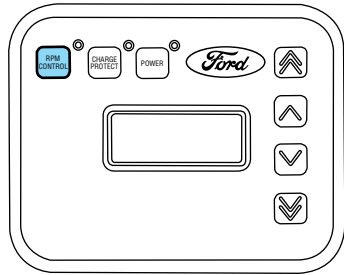

Charge Protect

This feature is used for maintaining the correct battery charge.

- In the “Charge Protection” mode, the battery voltage is monitored.
- When required, the engine's idle speed is increased so the battery charge is maintained.
- Charge Protection can be activated from inside the vehicle and programmed to activate automatically upon engine start-up.

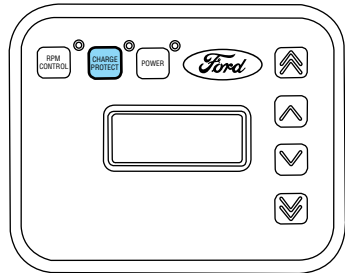

Driving tips

LCD screen

Displays current engine speed and battery voltage.

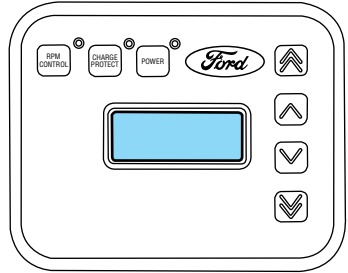

Arrow keys

Each arrow key contains a preset speed allowing four programmable rpm settings.

- The arrow keys can also be used to manually increase or decrease engine idle speed at a faster or slower rate.

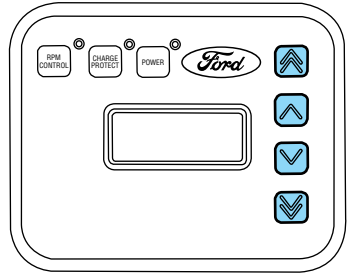

General maintenance information

SCHEDULED MAINTENANCE

The Scheduled Maintenance Services in the Service Guide are required because they are considered essential to the life and performance of your vehicle.

Use only recommended fuel, lubricants, fluids and service parts conforming to Ford specifications. Motorcraft parts are designed and built for best performance in your vehicle.

WASHING THE DIESEL ENGINE

Never wash the engine when it is warm, hot or running. Spraying water or other cleaning fluids on a warm engine can seriously damage the engine's fuel system. When washing the engine, the air cleaner must be in place to prevent water from splashing into the engine.

FUEL REQUIREMENTS

The engine is designed to use low sulfur number 1-D or 2-D diesel fuel only. At temperatures below -7°C (20°F), number 1-D or winter blend number 2-D fuel is recommended. (See "Cold Weather Operation" in the *Starting* chapter.)

Do not use fuel intended for agricultural use (agricultural fuel is dyed red), home heating oil or any diesel fuel not intended for highway use. Damage to the fuel injection system or engine can occur if an improper fuel is used.

Do not add gasoline, gasohol or alcohol to diesel fuel. This practice creates a serious fire hazard and engine performance problems.

It should not be necessary to add any aftermarket additives to your fuel tank if you use a properly formulated diesel fuel that meets the ASTM D 975 industry specification. Aftermarket additives can damage the injector system or engine.

Do not blend used engine oil with diesel fuel under any circumstances. Blending used oil with the fuel will significantly increase your vehicle's exhaust emissions and reduce engine life due to increased internal wear.



Do not crank the engine for more than 30 seconds at a time as damage to the starter motor may result.

General maintenance information

If the engine fails to start in 30 seconds, turn the key to the OFF position and wait 30 seconds before trying again.

Truck stops have pumps and nozzles designed for larger, heavy-duty trucks. When refueling at truck stops: if the nozzle shuts off repeatedly when refueling, wait 5–10 seconds; then use a slower rate of flow (don't depress the nozzle trigger as far).

If air is allowed to enter the fuel system (during fuel filter change or if you run out of fuel) the engine will purge the trapped air as it runs. The engine may run rough and produce white smoke while air is in the system. This is normal and should correct itself in a short time.

An engine that suddenly becomes noisy or operates poorly after a fuel fill could be using substandard fuel (i.e., high water content, low cetane rating or gasoline in the fuel). Diesel fuel should be purchased from a reputable station which sells a large amount of diesel fuel.

Care should be taken whenever diesel fuel is stored. Use only clean, approved containers which will prevent the entry of dirt or water.

Diesel fuel must not be stored in a galvanized container. The fuel will dissolve the zinc in a galvanized container. The zinc will then remain in solution until it is run through the engine where it will be deposited in the fuel injectors causing expensive-to-repair damage.

General maintenance information

CHANGING FUEL FILTER

Removal

1. Remove the fuel filter cap by turning counterclockwise.
2. Remove and discard old bevel gasket.
3. Remove and discard old fuel filter element and fuel filter o-ring.
4. Carefully clean the mating surfaces.

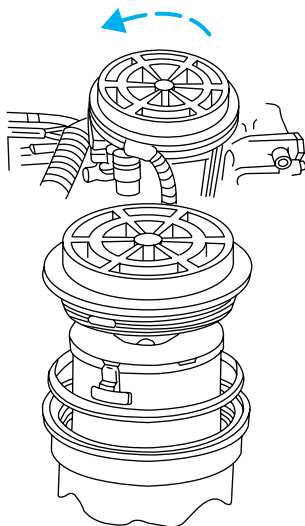

Installation



The engine will not run properly if the fuel filter is not installed in housing.

1. Apply a coating of clean diesel fuel to the new bevel gasket and fuel filter o-ring.
2. Install new bevel gasket onto housing.
3. Install new fuel filter o-ring onto fuel filter element.
4. Install new fuel filter and o-ring into the fuel filter housing.
5. Tighten cap onto fuel filter housing slowly, allowing fuel to soak into the fuel filter element. Tighten cap until it contacts the housing.

After replacing the fuel filter, the engine will purge the trapped air as it runs. The engine may run roughly and smoke until the air is completely eliminated.

General maintenance information

Using a fuel which has more than average impurities may require the fuel filter to be replaced more frequently than the service interval specifies.

ENGINE OIL

Checking engine oil level

Because it is normal to add some oil between oil changes, check your engine oil level each time you stop for fuel. To check the engine oil level consistently and accurately, the following procedure is recommended:

1. Have engine at normal operating temperature (at least into the NORMAL range on the engine coolant temperature gauge).
2. Park the vehicle on a level surface, then turn off the engine and open the hood.
3. Allow at least **20 minutes** after engine shutdown to assure that the oil contained in the upper parts of the engine has returned to the oil pan.
4. Protecting yourself from engine heat, pull out the dipstick, wipe it clean and reinsert fully.

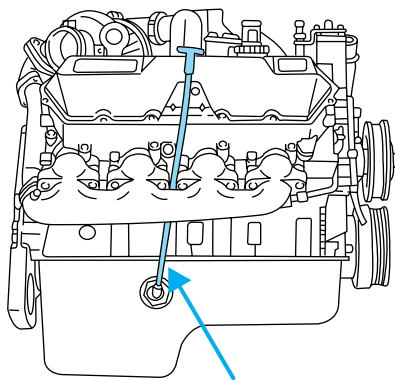

5. Read oil level on both sides of dipstick and use highest level (reading) for the actual engine oil level.
6. Maintain the oil level between ADD and OPERATING RANGE on the dipstick by adding oil as required. The distance from ADD to OPERATING RANGE on the dipstick represents 1.9L (2 quarts). Do not overfill. If the oil level exceeds OPERATING RANGE, oil consumption may result.

General maintenance information

Engine oil specifications

To help achieve proper engine performance and durability, it is important that only engine lubricating oils of the proper quality are used in your diesel engine and that the engine oil is changed **no later** than the recommended interval. Diesel engines require specially formulated oil to resist contamination. Proper quality oils also provide maximum efficiency of the crankcase ventilating system which reduces air pollution.

For normal or severe service, use Motorcraft oil or an equivalent oil conforming to Ford Specification WSS-M2C171-C or API Service categories CG-4/SH. Do not use oil labeled with only one of the following category designations; SG, SH, CE, CF-4, or CG-4, as they could cause engine damage.

Engine oils with improved fuel economy properties (energy conserving) are currently available. If you use an energy conserving oil, be sure it meets the recommended Ford Specification, API service categories and SAE viscosity grades listed in the Lubricant and Maintenance Materials Specifications chart. Some energy conserving oils *do not* meet the requirements necessary for your diesel engine.

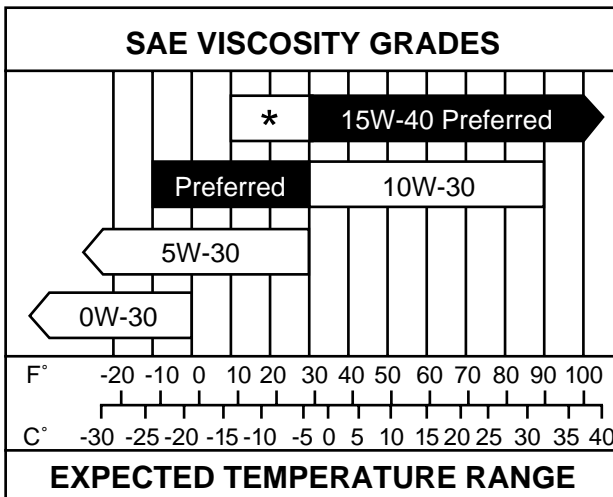

The use of correct oil viscosities for diesel engines is important for satisfactory operation. Determine which oil viscosity best suits the temperature range you expect to encounter for the next service interval.

General maintenance information

A symbol has been developed by the American Petroleum Institute (API) to help you select the proper engine oil. It will be included on the oil container you purchase. The top section of the symbol shows the oil performance by the API designation.

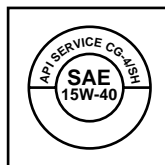

This should match the owner guide recommendation. The center section will show the SAE viscosity grade. The lower section will state energy conserving if the oil has proven fuel saving capabilities.

Changing engine oil and filter

Change your oil and filter according to the “Service Guide”. Change more frequently if your vehicle operation includes extended periods of idling or low-speed operation, driving for a long time in cold temperatures or driving short distances. See the following section “Engine Lubrication for Severe Service Operation” for all severe duty restrictions.

Use Ford Engine Oil Filter Part No. F4TZ-6731-A (FL-1995) or equivalent. These filters protect your engine by filtering harmful, abrasive or sludge particles. The FL-1995 filters particles significantly smaller than most available “will fit” filters.

To replace, use an oil filter wrench to unscrew the filter from the oil cooler fitting. Turn it horizontally to let excess oil drain off, and remove.



Do not handle a hot oil filter with bare hands.

Clean the filter mounting area on the oil cooler, lightly coat the gasket surface of the new filter with clean engine oil and hand tighten until the gasket contacts the base. **Then tighten another 1-1/4 to 2 turns.** Fill the crankcase and run the engine to check for leaks.



Continuous contact with USED motor oil has caused cancer in laboratory mice. Protect your skin by washing with soap and water.

General maintenance information

Engine lubrication for severe service operation

The following severe service operating conditions require unique engine maintenance procedures:

- towing a trailer over 1 600 km (1 000 miles)
- sustained, high speed driving at Gross Vehicle Weight Rating (maximum loaded weight for vehicle operation during hot weather-above 32°C [90°F]).
- frequent or extended idling (over 10 minutes per hour of normal driving).
- operating in severe dust conditions.
- frequent, short trips of 16 km (10 miles) or less during freezing weather

If you are operating your vehicle under any of these conditions, observe the following service procedures:

- Change engine oil and filter every 5 000 km (3 000 miles).
- Use Motorcraft oil or an equivalent oil conforming to Ford Specification ESR-M2C171-C or API categories CG-4/SH. Do not use oils labeled with *only* one of the following category designations, SG, SH, CE, CF-4 or CG-4, as they could cause engine damage.

For more information refer the *Severe Duty Maintenance Schedule* in the “Service Guide”.

REPLACING THE AIR FILTER ELEMENT

When replacing the air filter element, use the Motorcraft air filter element listed. Refer to *Lubricant and Maintenance Materials Specifications* in this supplement.



Failure to use the correct air filter element may result in severe engine damage.

1. Remove air filter element from the housing, taking care to prevent dirt from falling into the engine air intake.
2. Clean the air filter housing and cover to ensure good sealing.
3. Install a new air filter element. Be careful not to crimp the filter edges between the air filter housing and cover. This could cause damage to the air filter element and possible severe damage to the engine.

General maintenance information

4. After replacing the air filter element, be sure that the rubber water drain hose is not kinked under the air filter housing. If so, adjust the hose so that it hangs free.



When servicing the air filter, always be sure that the rubber water drain hose is not kinked or obstructed. Failure to do so may result in severe engine damage when driving through deep water and/or encountering unusually heavy precipitation conditions.

FUEL FILTER/WATER SEPARATOR

The engine is equipped with a combination fuel filter/water separator located in the “V” of the engine.

Water should be drained from the filter bowl whenever the warning light comes on or every 8 000 km (5 000 miles). The WATER IN FUEL light will come on when

approximately 100 cc (0.2 pints) of water accumulates in the separator.

Replace the fuel filter with Motorcraft Part No. FD-4596 (Ford Part No. F81Z-9N184-AA).

**WATER
IN
FUEL**

General maintenance information

Fuel filter/water separator drain procedure

1. Stop the vehicle and **shut off** the engine.



The vehicle must be stopped with the engine off when draining the fuel filter/water separator. Fuel may ignite if separator is drained while the engine is running or vehicle is moving.

2. Open the hood. Place an appropriate container under the filter drain under the vehicle.

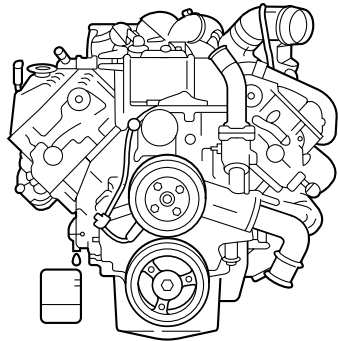

3. Locate the fuel filter drain valve. Refer to “Engine Compartment” in the *Service points* chapter.

4. **On F-Series and Excursion models**, open fuel filter drain valve by turning clockwise. Allow to drain for approximately 25 seconds or until clean fuel is observed. Close filter drain valve by turning counterclockwise until firmly seated.

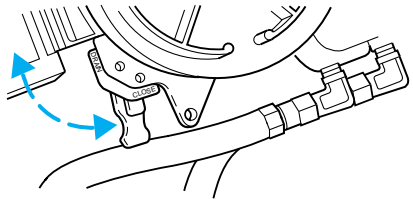

General maintenance information

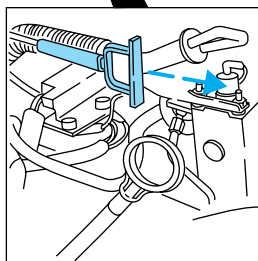
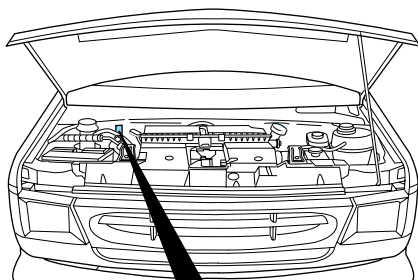

4. **On Econoline models**, open fuel filter drain valve by pulling on the release handle. Allow to drain for approximately 25 seconds or until clean fuel is observed. Close filter drain valve by resetting handle to original position.
5. **On all models**, verify that the fuel filter drain valve is closed. Close the hood and remove the container from under the vehicle.
5. Restart the engine and check WATER IN FUEL indicator light. The light should not glow. If it continues to glow, have fuel system checked and repaired.

ENGINE COOLANT

Replacing coolant

A coolant mixture of 50% coolant concentrate and 50% water is recommended to maintain best overall performance. To avoid damaging the engine and radiator, the coolant concentrate should not exceed 60%. When refilling the coolant system either as part of the regular maintenance (48 months, or 80 000 km [50 000 miles], whichever comes first and then every 36 months or 48 000 km [30 000 miles], whichever

General maintenance information

comes first), or due to service performed, adhere to the following instructions:

1. Drain and flush the cooling system to remove dirt deposits, oil, rust particles.
2. Add 1.89L (4 pints) of supplemental coolant additive FW-15, directly to the cooling system. An additional 237–295 ml (8–10 oz.) of supplemental coolant additive FW-15 should be added at 24 000 km (15 000 mile) intervals to maintain proper concentration.
3. Fill the coolant reservoir with the specified coolant/water mixture until the level stabilizes at the top hose fitting. Replace and tighten cap. Fill the radiator when cold. Level the coolant in the coolant bottle.
4. Reinstall the coolant bottle cap.
5. Start and idle engine until the radiator upper hose is warm (approximately 10–15 minutes). If the hose does not get warm then repeat at a higher engine speed.
6. Immediately shut off engine. Cautiously remove coolant bottle cap and add coolant to Cold Fill mark.

Checking coolant level

Check coolant level in coolant reservoir bottle at least once a month, only when the engine is cool. Fill to within the “Cold Fill Level” range noted on the reservoir as required with a 50/50 mixture of coolant concentrate and water.

A coolant mixture of 50% coolant concentrate and 50% water is recommended to maintain best overall performance. A 60/40 antifreeze to water ratio is acceptable for extremely cold climates, but must be returned to a 50/50 ratio at the end of the winter season.

Vehicles with diesel engines typically are used to carry heavy loads and accumulate mileage rapidly. These two factors cause the additives in the coolant to “wear out” in a shorter time. Ford recommends an interim service interval performed at 12 months or 24 000 km (15 000 miles), whichever occurs first. Add 237–295 ml (8–10 oz.) of supplemental coolant additive FW-15 to the cooling system. For vehicles with extensive idling time, add 237–295 ml (8–10 oz.) of coolant additive FW-15 after every 500 hours of operation.

Operating engine with insufficient coolant and/or coolant additive can cause severe engine damage.

General maintenance information



Failure to follow these instructions could result in serious personal injury from hot coolant or steam blow out and/or damage to the cooling system or engine. Never remove the coolant bottle cap under any circumstances while the engine is operating. Switch off the engine and wait until it has cooled. Wrap a thick cloth around the cap and turn it slowly while the pressure is relieved. Step back while the pressure is released from the cooling system. When you are sure all the pressure has been released, still with a cloth — turn and remove it. Stand clear of the opening. Hot coolant may splash out.

Whenever coolant level checks are made, check condition of coolant bottle cap rubber seal. Make sure it is clean and free of any dirt particles. Rinse off with water, if necessary. When replacing cap on coolant bottle, also make sure coolant bottle neck seal is clean. Check that overflow hose is not kinked.

Coolant specification

Use only a permanent-type coolant that meets Ford Specification ESE-M97B44–A such as Ford Premium Cooling System Fluid E2FZ-19549–AA. Do not use alcohol or methanol antifreeze or mix them with the specified coolant.

Use of the wrong coolant may cause radiator and/or engine damage.

Plain water may be used in an emergency, but replace it with the specified coolant as soon as possible to avoid damage to the system. With only water in the system, do not let the engine run hot or remain parked in temperatures below 0°C (32°F).

Coolant conditioner (liquid)

A supplemental coolant additive FW-15 has been added to the coolant in this engine.

This additive aids in the prevention of rust and scale buildup on the internal parts of the cooling system. Prevention of rust and scale buildup allows for proper dissipation of heat generated by combustion.

See the “Service Guide” for recommended intervals.

General maintenance information

EMISSION CONTROL SYSTEM(S) LAWS

Federal law prohibits vehicle manufacturers, dealers and other persons engaged in the business of repairing, servicing, selling, leasing or trading motor vehicles as well as fleet operations from unknowingly removing or rendering emission control system(s) inoperative. Further, modifications of the emission control system(s) could create liability on the part of the individual owners under the laws of some states. In Canada, modifications of the emission control system(s) could create liability under applicable Federal or Provincial laws.

Do not remove or alter the original equipment floor covering or insulation between it and the metal floor of the vehicle. The floor covering and insulation protect occupants of the vehicle from the engine and exhaust system heat and noise. On vehicles with no original equipment floor covering insulation, do not carry passengers in a manner that permits prolonged skin contact with the metal floor. Provide adequate insulation.

NOISE EMISSIONS WARRANTY, PROHIBITED TAMPERING ACTS AND MAINTENANCE

On January 1, 1978, Federal regulation became effective governing the noise emission on trucks over 4 536 kg (10 000 lbs.) GVWR (Gross Vehicle Weight Rating). The following statements concerning prohibited tampering acts and maintenance, and the noise warranty found in the Warranty Facts Booklet, are applicable to complete chassis cabs over 4 536 (10 000 lbs.) GVWR.

Tampering with noise control system prohibited

Federal law prohibits the following acts or the causing thereof: (1) The removal or rendering inoperative by any person other than for purposes of maintenance, repair or replacement of any device or element of design incorporated into any new vehicle for the purpose of noise control prior to its sale or delivery to the ultimate purchaser or while it is in use, or (2) the use of the vehicle after such device or element of design has been removed or rendered inoperative by any person.

Among those acts which the U.S. Environmental Protection Agency may presume to constitute tampering are the acts listed below:

- Removal of hood blanket, fender apron absorbers, fender apron barriers, underbody noise shields or acoustically absorptive material.
- Tampering or rendering inoperative the engine speed governor, so as to allow engine speed to exceed manufacturer's specifications.

Scheduled maintenance

VEHICLE EMISSIONS CONTROL INFORMATION (VECI)

Emissions information appears on the VECI decal on the engine valve cover. This decal identifies engine displacement and provides certain engine specifications.

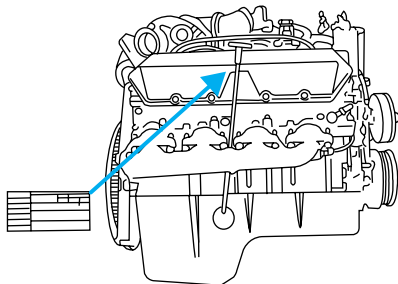

SCHEDULED MAINTENANCE SERVICES

Refer to your “Service Guide” for details of maintenance on your vehicle.

If you are using your vehicle in a manner in which it will remain stationary (door to door service, taxi, etc.), then it is recommended that you change the engine oil every 200 engine hours as opposed to a mileage limit. Since most vehicles are not equipped with hourmeters, it may be necessary for you to approximate your time and plan engine oil and filter changes accordingly.

Any modification of the emissions control system could create liability under federal law (U.S.) if made prior to sale and registration, under the laws of some states if made thereafter. Further, federal law prohibits vehicle manufacturers, dealers and other persons engaged in the business of repairing, servicing, selling, leasing or trading motor vehicles as well as fleet operations from knowingly removing or rendering an emissions control system inoperative after sale and delivery to an ultimate purchaser. In Canada, modifications of the emissions control system could create liability under applicable federal or provincial laws.

Minor troubleshooting guide

The complexity of the diesel engine makes it so the owner is discouraged from attempting to perform maintenance other than the services described in this supplement.

If you experience difficult starting, rough idling, excessive exhaust smoke, a decrease in engine performance or excess fuel consumption, perform the following checks:

- a plugged air inlet system.
- water in the fuel filter/water separator.
- a clogged fuel filter.
- contaminated fuel.
- air in the fuel system, due to loose connections.
- an open or pinched sensor hose.
- low engine oil level.
- wrong fuel for climactic conditions.

If these checks do not help you correct the engine performance problem you are experiencing, consult an authorized dealer.

FUELING



Do not use starting fluid such as ether or gasoline in the diesel air intake system. Such fluids can cause immediate explosive damage to the engine and possible personal injury.

If you fuel your vehicle at a truck stop, you may notice that the fuel nozzle may shut off every 5–10 seconds. This is due to the flow rates being designed for larger heavy duty trucks. You may have to fuel at a slower rate (don't depress the nozzle trigger fully).

Do not run your diesel vehicle out of fuel as this will allow air to enter the fuel system which will make restarting difficult. Longer engine cranking time may be required once air is in the fuel system. If air enters the fuel system (either through running the fuel tank(s) empty or during a fuel filter change), the engine will self-purge the trapped air once it starts running. The engine may run roughly and produce white smoke while air is in the fuel system; this is normal and should stop after a short time.

Minor troubleshooting guide

IF THE ENGINE WON'T CRANK

Turn on the headlights. If the lights are dim, do not go on at all or if when the ignition is turned to START the lights become dim or go out, the battery connections may be loose or corroded, or the battery may be discharged. If there is a clicking or stuttering sound coming from the engine compartment when you turn the key to START, this may also indicate a loose or corroded battery connection.

Check the battery connections at the battery posts, cable connection to the engine grounding point and at the starter relay terminals. Also, make sure the relay bracket is securely fastened to its mounting surface.

If the starter relay clicks, but the starter does not crank, check the connections at the starter terminal. If a discharged battery is suspected, have it checked and corrected.

- For vehicles with manual transmissions, the clutch pedal **must** be fully depressed in order for the starter to operate.
- For vehicles with automatic transmissions, the gearshift lever must be in Park or Neutral in order for the starter to operate.
- Try operating the starter switch several times. Should the switch be corroded, this operation may clean the contacts or make the switch temporarily operable until you can reach the dealer.
- If all electrical connections are tight and you need assistance to start, see “Jump Starting Your Vehicle” in the *Starting* chapter.

IF ENGINE CRANKS BUT WON'T START

Prolonged starter cranking (in excess of 30 seconds) could cause damage to the starter motor.

- Check the fuel gauge. You may be out of fuel. If the gauge shows that there is fuel in the tank, the trouble may be in the electrical system or the fuel system. If equipped with an auxiliary tank, be sure that the tank control switch is set for the tank with fuel and not on an empty tank.
- Leaving the ignition key ON for over two minutes without starting may make starting difficult because the glow plugs will cease activation. Reset the system by turning the ignition key to OFF and then back to ON again.

Minor troubleshooting guide

IF THE ENGINE RUNS HOT

The following could cause the engine to overheat:

- Lack of coolant.
- Dirty cooling system.
- Driving with frozen coolant.
- Sticking thermostat.
- Overloading or pulling heavy trailers during hot weather.
- Grill or radiator air blockage.
- Slipping or missing drive belt.
- Plugged or very dirty air cleaner element.

IF FUSES BURN OUT

Burned-out or blown fuses usually indicate an electrical short-circuit, although a fuse may occasionally burn out from vibration. Insert a second fuse. If this fuse immediately burns out and you cannot locate the cause, return your vehicle to your dealer for a circuit check.



Replacement fuses and circuit breakers must always be the same rating as the original equipment shown. Never replace a fuse or circuit breaker with one of a higher rating. Higher rated fuses or circuit breakers could allow circuit overloading in the event of a circuit malfunction, resulting in severe vehicle damage or personal injury.

Refer to the “Owner Guide” for replacement of fuses.

Capacities and specifications

REFILL CAPACITIES

Component	Capacity
Cooling system (F-Series and Excursion) ¹	31.0L (32.75 quarts)
Cooling system (Econoline) ^{1, 2}	28.5L (30.0 quarts)
Engine oil ³	14.2 L (15.0 quarts)
Fuel tank (F- Series)	Refer to Owner Guide
Fuel tank (Excursion)	166.6L (44.0 gallons)
Fuel tank (Econoline) ⁴	132.5L (35.0 gallons)
Radiator cap	90 kPa (13 psi)
Manual transmission ⁵	3.2L (3.4 quarts)
Automatic transmission	Refer to Owner Guide

¹ Includes heater and 4.7L (5 quarts) in coolant recovery.

² Add 2.5L (2.6 quarts) if equipped with auxiliary heater option.

³ Includes 1.9L (2 quarts) in engine oil filter.

⁴ Optional DRW cutaway and all standard E-450 models are 208.2L (55.0 gallons).

⁵ Use Motorcraft MERCON® ATF, Ford part number XT-2-QDX, meeting Ford specification MERCON®.

BULB SPECIFICATIONS

Lamp description	Number of bulbs required	Trade number
Wait to Start Light	1	194
Water-in-Fuel Light	1	194
Engine Temp. Light	1	194
Fuel Filter	1	194

Capacities and specifications

LUBRICANT AND MAINTENANCE MATERIALS SPECIFICATIONS

Item	Ford Part Name	Ford Part Number	Ford Specification
Engine Oil	Motorcraft Motor Oil 15W40 Super Duty, 10W30 Super Duty	XO-15W40-QSD, XO-10W30-QSD	WSS-M2C171-C, CH-4/SJ/SH
Engine Oil Filter (Use this filter Only)	-	F4TZ-6731-A (FL-1995)	-
Air Filter (F-Series and Excursion) ¹	-	FA-1680	ES-E95AE- 9601-AA
Air Filter (Econoline) (2 Required)	-	FA-1618	ES-E95AE- 9601-AA
Battery (2 Required)	-	BXT-65-750	-
Engine Coolant	Premium Cooling System Fluid	E2FZ-19549-AA	ESE-M97B44-A
Engine Coolant Additive	-	FW-15	-

¹ Always use the authorized Motorcraft air filter listed.



Failure to use the correct air filter may result in severe engine damage.

Service points

ECONOLINE ENGINE COMPARTMENT

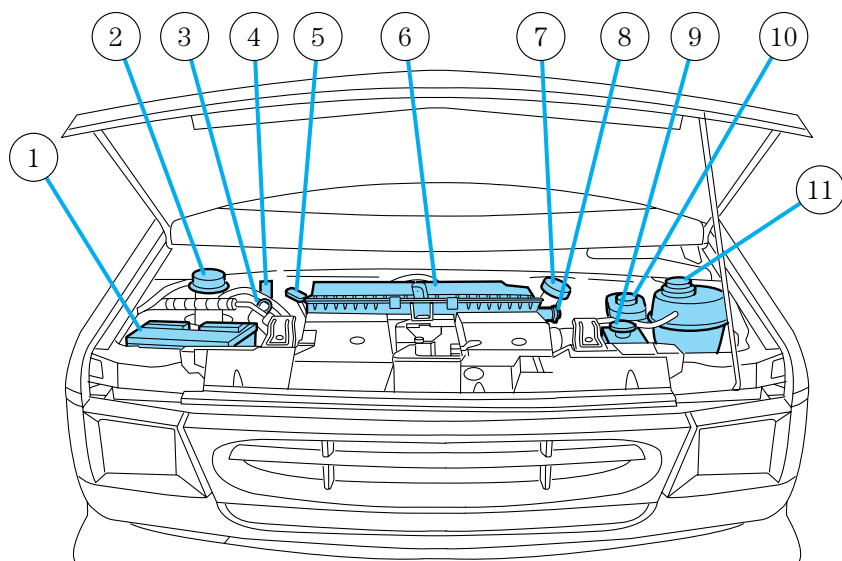

1. Battery
2. Windshield washer fluid reservoir
3. Engine oil dipstick
4. Fuel filter/water separator drain valve release handle
5. Automatic transmission fluid dipstick
6. Air filter assembly
7. Engine oil filler
8. Air filter restriction gauge
9. Power steering fluid reservoir
10. Brake fluid reservoir
11. Engine coolant recovery reservoir

Service points

F-SERIES AND EXCURSION ENGINE COMPARTMENT

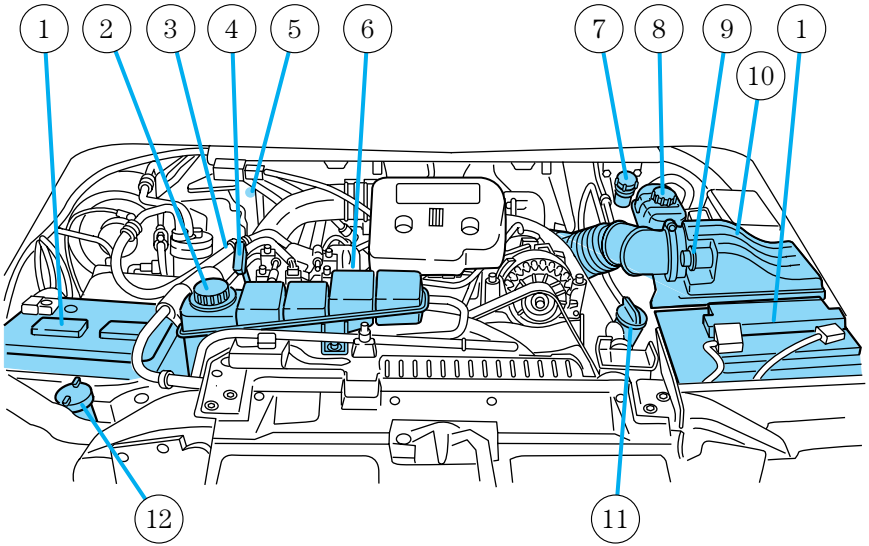

1. Battery (dual batteries shown)
2. Engine coolant recovery reservoir
3. Engine oil filler
4. Engine oil dipstick
5. Automatic transmission dipstick (if equipped)
6. Fuel filter drain valve
7. Clutch fluid reservoir (if equipped)
8. Brake fluid reservoir
9. Air filter restriction gauge
10. Air filter assembly
11. Power steering fluid reservoir
12. Windshield washer fluid reservoir