

Table of contents

BEFORE DRIVING

Introduction	2
Instrumentation	9
Controls and features	13
Seating and safety restraints	59

STARTING AND DRIVING

Starting your vehicle	89
Driving	96
Roadside emergencies	118

SERVICING

Maintenance and care	136
Capacities and specifications	185
Reporting safety defects	192
Index	193
Filling station information	200

Introduction

The following icons appear in this *Owner's Guide*:  

 indicates a warning. Read the following section on *Warnings* for a full explanation of warnings.

 indicates that vehicle information related to recycling and other environmental concerns will follow.

Warnings

Warnings remind you to be especially careful in those areas where carelessness can cause damage to your vehicle or personal injury to yourself, your passengers or other people. Please read all Warnings carefully.

Notice to owners of utility-type vehicles

As with other vehicles of this type, failure to operate this vehicle correctly may result in loss of control or an accident. Be sure to read *Special driving instructions for AWD vehicles* later in this Owner's Guide and the special supplement included with AWD and 4x4 vehicles entitled *Four-Wheeling*.

Four-Wheeling presents safe driving practices to owners of AWD and 4x4 utility vehicles. Your AWD vehicle handles differently than an ordinary passenger car and has some special safety considerations. This is because your AWD vehicle has several design and equipment

differences for towing, hauling, and off-road operation. For this reason, Mercury urges you to read and understand the contents of the *Four-Wheeling* supplement.

Breaking in your vehicle

Your new vehicle goes through an adjustment or breaking-in period during the first 1,000 miles (1,600 km) of driving. During this period:

- Change your vehicle's speed often as you drive. Do not drive at one speed for a long time.
- Use only the type of engine oil Ford recommends. Do not use special "break-in" oils.
- Avoid sudden stops. The break-in period for brake linings lasts for 1,600 km (1,000 miles) of highway driving or 160 km (100 miles) of city driving.

Information about this guide

This guide describes equipment and gives specifications for equipment that was in effect when this guide was approved for printing. Mercury may discontinue models or change specifications or design without any notice and without incurring obligation.

Instrumentation

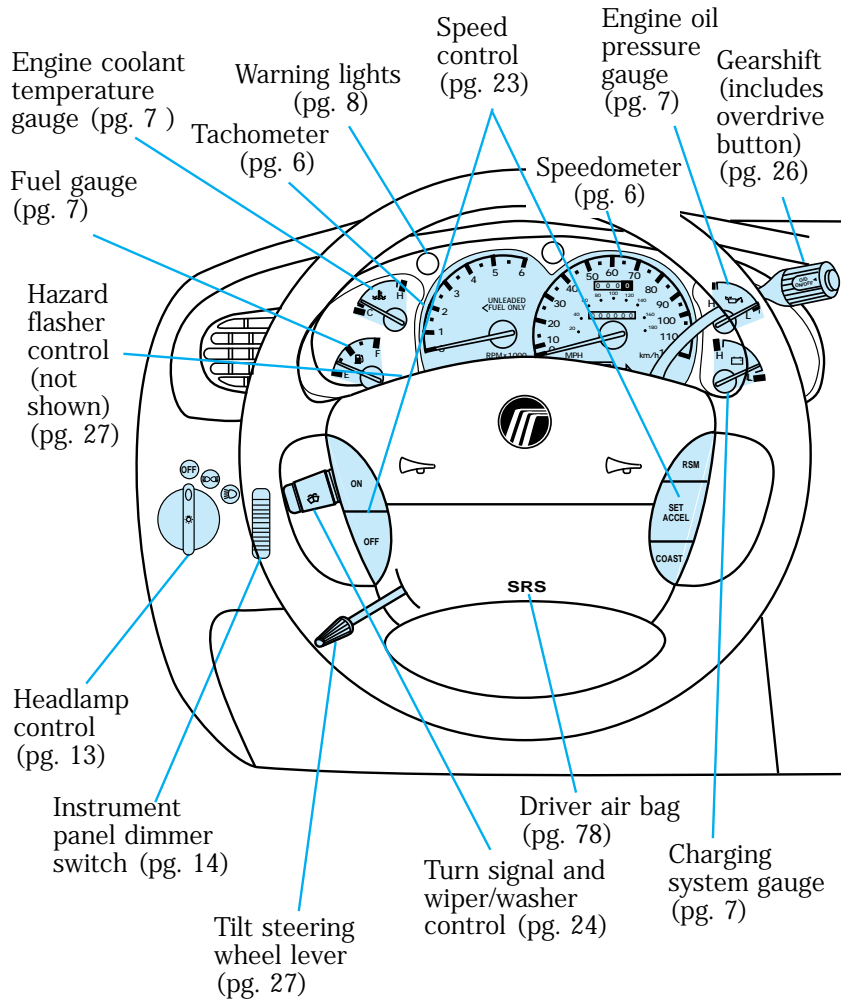

Instrumentation

Electronic sound system; refer to *Audio Guide* (premium stereo cassette with CD DJ shown) (pg. 16)

Vents (pg. 17)

Rear wiper/washer control (pg. 15)

Rear window defroster control (pg. 15)

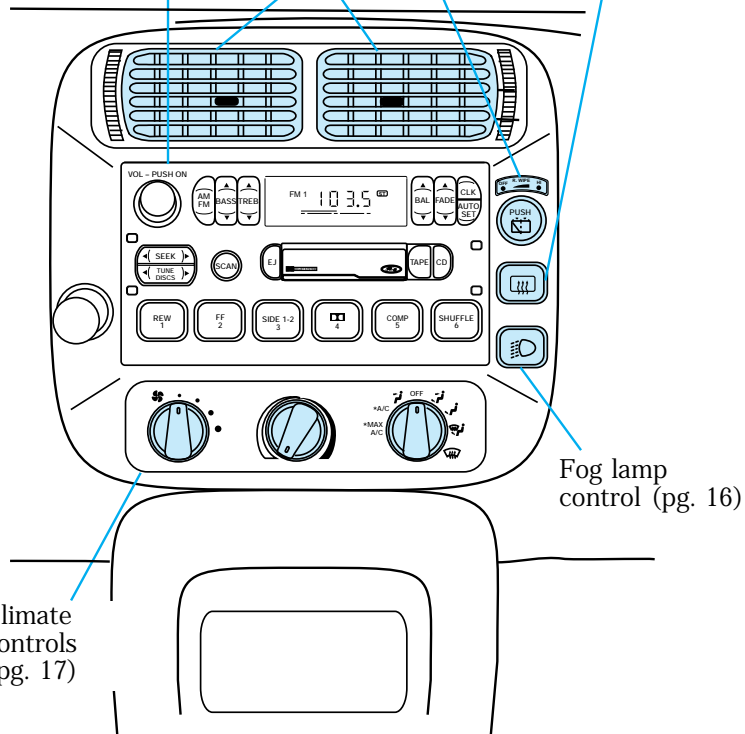

Instrumentation

INSTRUMENT CLUSTER

Instrument cluster gauges

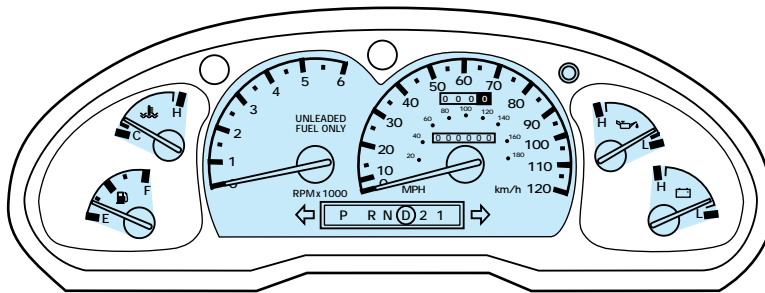

Speedometer

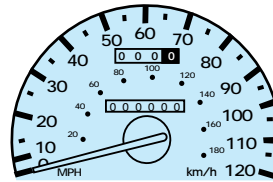

Tachometer

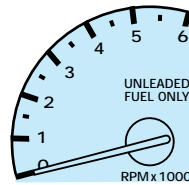

Instrumentation

Engine coolant

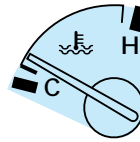

Fuel gauge

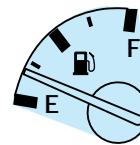

Voltage gauge

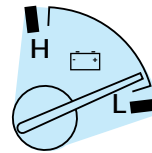

Oil pressure

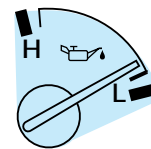

Odometer

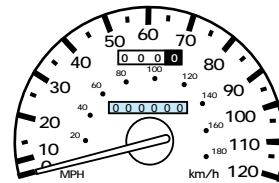

Trip odometer and reset button

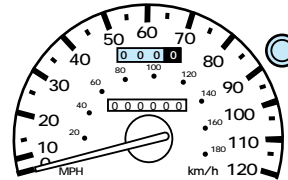

Instrumentation

Instrument cluster warning and indicator lights

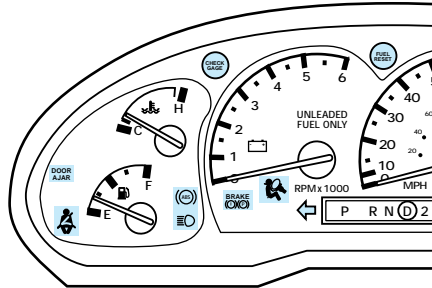

DOOR AJAR illuminates when the ignition key is turned to the ON or START position and a door or liftgate is opened.

CHECK GAGE illuminates when the ignition is turned to ON and the engine temperature is high, the oil pressure is low, or the fuel level is near empty.

+ **-** illuminates when there is a problem with the generator or charging system.

FUEL RESET illuminates when the ignition key is turned to ON and the fuel pump shutoff switch has been triggered. Refer to *Fuel pump shutoff switch* in *Roadside emergencies* for more information.

 illuminates when the air bag system requires servicing.

**DOOR
AJAR**

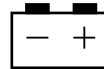

**FUEL
RESET**



Instrumentation

 **BRAKE** illuminates when the parking brake is activated, brake fluid level is low, or break system requires service.

BRAKE



 illuminates when the headlamp high beams are on.



 illuminates when the anti-lock brake system requires service.

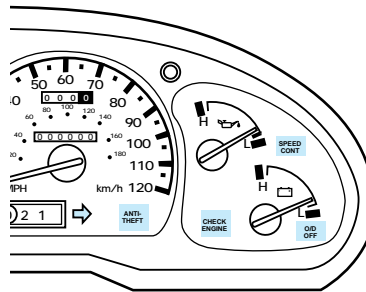

 illuminates when the ignition key is turned to ON and the safety belt is not buckled. The light will remain illuminated for one to two minutes or until the safety belt is buckled.



 **SPEED CONT** illuminates when the engine is running and speed control is turned on.

SPEED CONT

Instrumentation

$\frac{O/D}{OFF}$ the transmission control indicator light (TCIL) illuminates when the transmission control switch on the end of the gearshift lever is pushed and the $\text{\textcircled{D}}$ (Overdrive) mode is turned off.

**O/D
OFF**

$\frac{O/D}{OFF}$ indicates the status of the transmission and may flash steadily if a malfunction is detected. If flashing persists, have your transmission serviced by your dealer as soon as possible.

If this condition persists, your transmission may be damaged.

$\frac{CHECK}{ENGINE}$ illuminates when the emission control system requires service.

**CHECK
ENGINE**

THEFT (if equipped) illuminates when the anti-theft system is arming and flashes when the anti-theft system is armed. Refer to *Interior features* for additional information regarding the anti-theft system.

THEFT

$\blacktriangleleft \blacktriangleright$ illuminates when the left-hand or right-hand turn signal or the hazard lamps are illuminated.

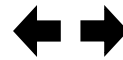

Instrumentation

How to test the instrument cluster lights

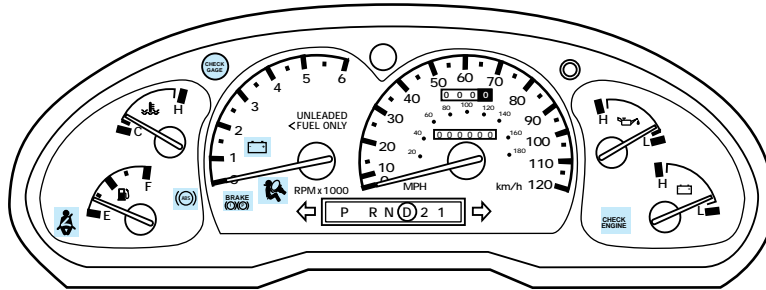

Turn the ignition key to ON without starting the engine. The warning and indicator lights shown above will illuminate for a brief time. If any of these lights do not illuminate, have your vehicle serviced.

Warning chimes

Safety belt warning chime

Refer to the *Seating and safety restraints* chapter for information on the safety belt warning chime.

Supplemental restraint system (SRS) warning chime

Refer to the *Seating and safety restraints* chapter for information on the SRS warning chime.

Key-in-ignition warning chime

A warning chime sounds when the key is left in the ignition in the OFF, LOCK, or ACCESSORY position and the driver's door is opened.

Instrumentation

Headlamps on warning chime

A warning chime sounds when the headlamps are on (and key is not in the ignition), the ignition is off, and a door is opened.

Controls and features

INSTRUMENT PANEL CONTROLS

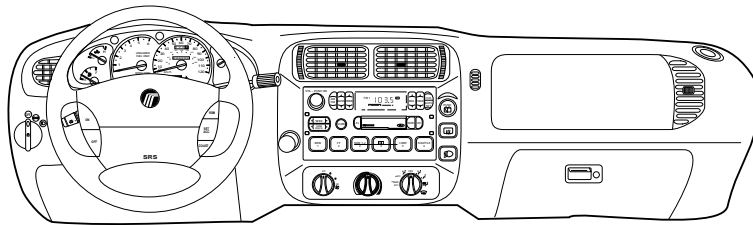

Headlamp switch

This switch operates the parking lamps and headlamps.

OFF Exterior lamps off

 Parking lamps ON

 Headlamps ON

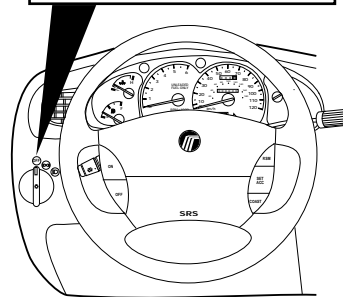
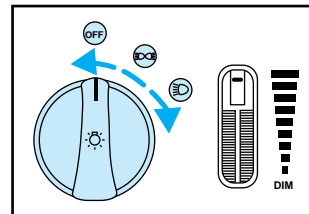

Autolamp delay system (if equipped)

The autolamp sets the headlamps to turn on and off automatically. Refer to *Overhead controls* for instructions on using the autolamp.

Controls and features

Daytime running light (DRL) system (if equipped)

The daytime running light (DRL) system turns the high beam lamps on, with a reduced light output, when:

- The headlamp knob is in the OFF position.
- The engine is running.
- The parking brake is released.

 The daytime running light (DRL) system will not illuminate the tail lamps and parking lamps. Turn on your headlamps at dusk. Failure to do so may result in a collision.

Panel dimmer dial

Instrument panel illumination, interior lamps and cargo lamp brightness can be adjusted with this dial.

Move thumbwheel up to brighten lamps. Move thumbwheel down to dim lamps.

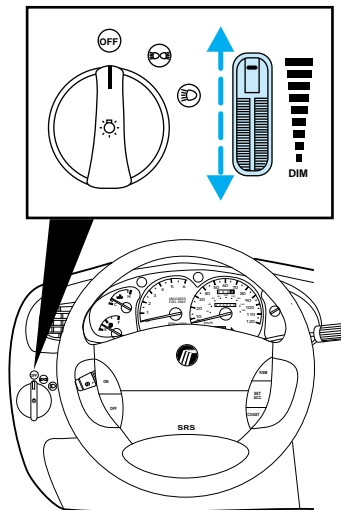

Controls and features

Liftgate wiper and washer

Turn the knob to adjust wiper speed. Push the knob in to activate the washer.

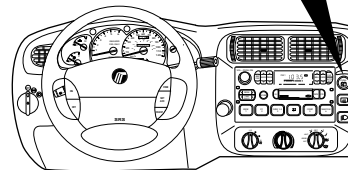
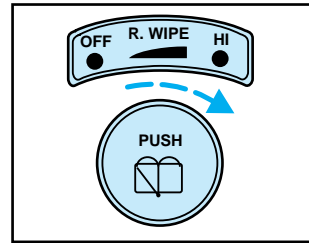

Rear window defroster

Push the button to activate the defroster. The indicator light will turn on and the defroster will turn off automatically in ten minutes. Push the button again to turn off.

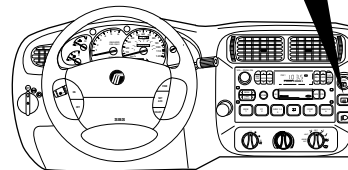
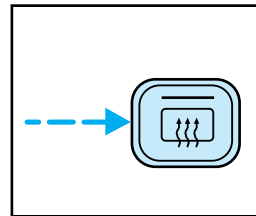

Controls and features

Foglamps

Push the button to activate the foglamps. The indicator light will turn on. The foglamps can be turned on only when the low beam headlamps are on. Push the button again to turn off.

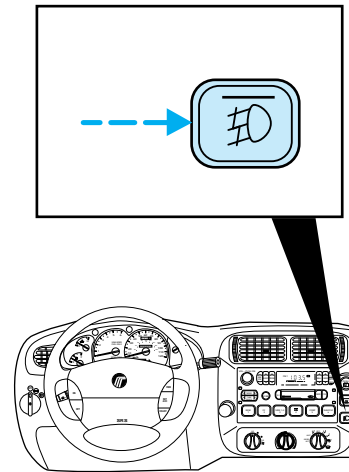

Audio system

Refer to the *Audio Guide* for instructions on how to operate the audio system.

Fuel pump shutoff switch

Refer to the *Roadside emergencies* chapter for instructions on how to operate the fuel pump shutoff switch.

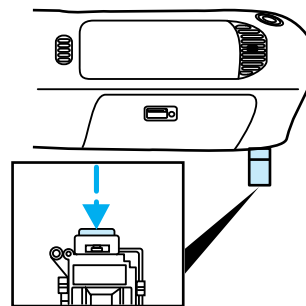

Controls and features

Climate controls

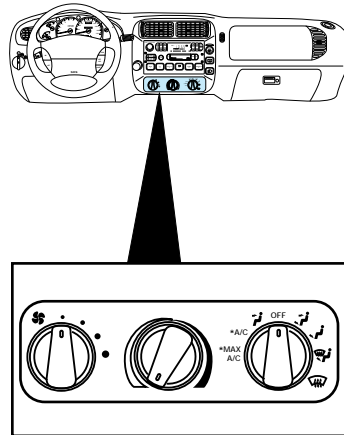

Instrument panel vents

There are four vents on the instrument panel. These vents are equipped with dials to adjust the amount and direction of air passing through them.

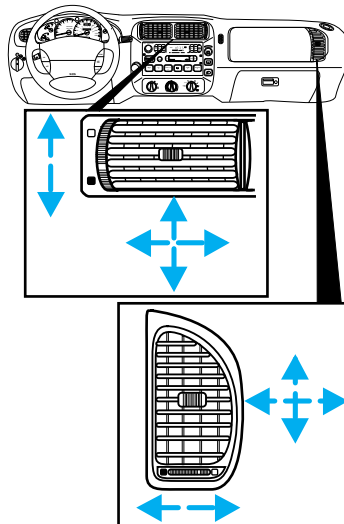

Controls and features

Operating climate controls

- Turn the temperature control to the desired temperature.

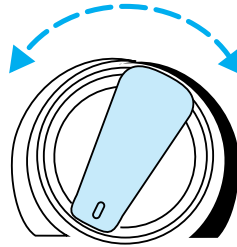

- Turn the fan speed control to the desired speed.

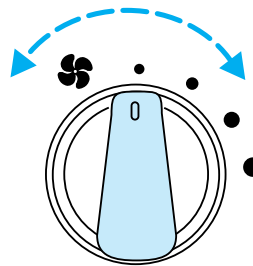

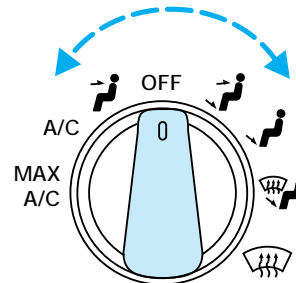

- Turn the mode control to the desired airflow position.





Controls and features

Controlling airflow

Select  for air to flow through these vents:

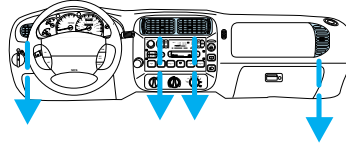
The  position allows outside air to flow through the instrument panel vents.



Select  for air to flow through these vents:

The  position directs outside air to flow between the panel and floor vents. The air conditioning will function provided the outside temperature is above 10°C (50°F).

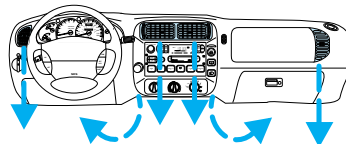

Select  for air to flow through these vents:

The  position directs outside air to flow through the floor vents.

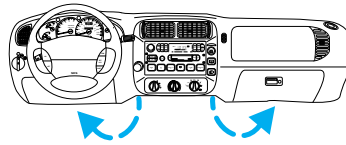

Select  for air to flow through these vents:

The  position directs outside air to flow through the floor vents and the windshield defroster vents. The air conditioning will function to dehumidify the windows provided the outside temperature is above 10°C (50°F).

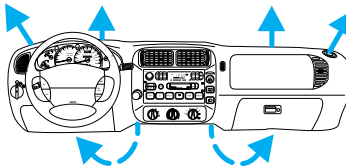

Select  for air to flow through these vents:

The  position directs outside air to flow through the windshield defroster vents. The air conditioning will function to dehumidify the windows provided the outside temperature is above 10°C (50°F).

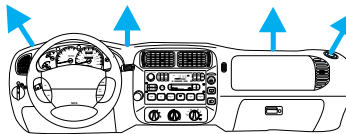

Controls and features

Select A/C for air to flow through these vents:

The A/C mode directs outside air conditioned air to flow through the instrument panel vents. The A/C mode can be used for heating, ventilating or air conditioning. The A/C mode only functions if the outside temperature is above 10°C (50°F).

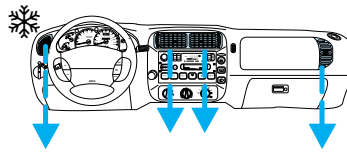

Select MAX A/C for air to flow through these vents:

The MAX A/C mode recirculates the air and directs it to flow through the instrument panel vents. The MAX A/C mode can be used for air conditioning or heating. This mode is noisier but more economical than A/C mode. The MAX A/C mode only functions if the outside temperature is above 10°C (50°F).

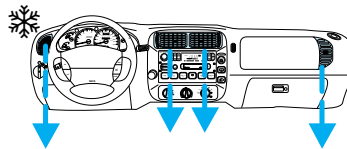

Select the OFF position for all climate control functions to cease. The outside inlet door will close and the fan is shut off.

Drive with the climate control system on (in either the heating or air conditioning mode) to reduce humidity in your vehicle.

Controls and features

Maximum heating

Set mode control to , turn temperature control to maximum heat (red) and set fan speed control to maximum.

Maximum cooling

Set mode control to MAX A/C, turn temperature control to maximum cool (blue) and set fan speed control to maximum.

Ventilating with outside air

Set mode control to , turn the temperature control to the desired temperature and turn fan speed control to desired position.

Maximum windshield defrosting

Set mode control to , turn temperature control to maximum heat (red) and set fan speed control to maximum speed.

- To prevent air intake restriction, remove any snow, ice or leaves from the air intake area located directly under the windshield.

Controls and features

STEERING COLUMN CONTROLS

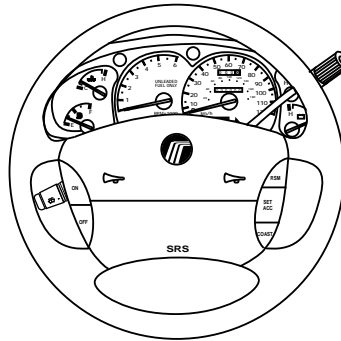

Positions of the ignition

ACCESSORY allows electrical accessories such as radio and wipers/washer to operate while the engine is not running.

LOCK locks the steering wheel and gearshift lever.

OFF shuts off the ignition and accessories and allows the gearshift lever and steering wheel to move.

ON tests the warning lights. The key remains here when engine is running.

START cranks the engine. The key returns to **ON** when released.

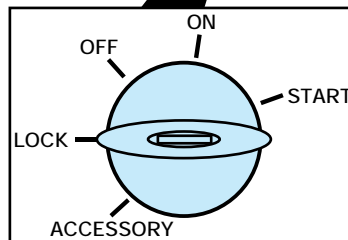
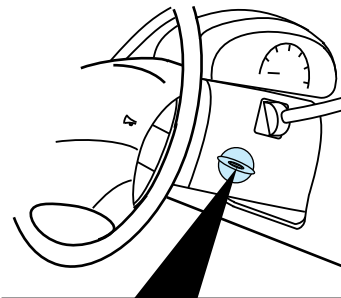

Controls and features

Speed control

 Do not shift the transmission into N with the speed control on.

Speed control maintains vehicle speed automatically at or above 48km/h (30 mph) using the control switches.

Press ON to turn speed control on. **SPEED CONT** will illuminate in the instrument cluster.

Press OFF to turn speed control off. When turned off, the previously programmed set speed will be erased.

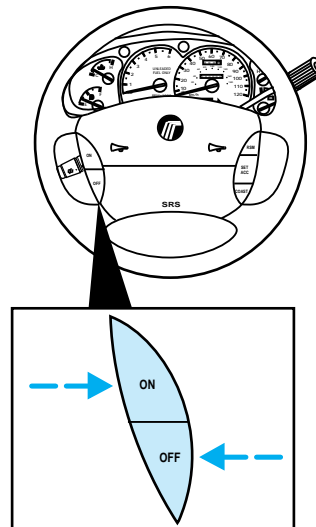

Controls and features

Press SET ACCEL (with speed control turned ON) to set speed. Hold SET ACCEL to increase speed. Press and release once to increase speed in 1.6 km/h (1 mph) increments.

Press COAST to decrease speed.

Press RSM to resume speed.

Depressing the brake pedal will cancel the speed control.

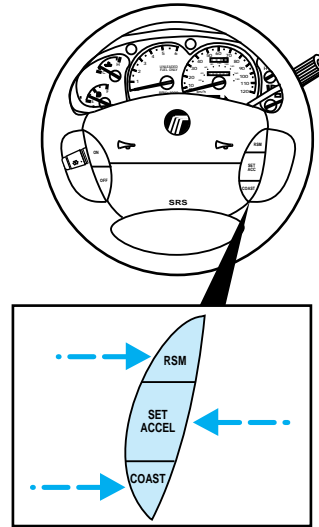

Wiper/washer controls

Push the end to activate the washer. Push end once for a single wipe. Push and hold for a constant cycle.

Turn the dial to adjust wiper speed.

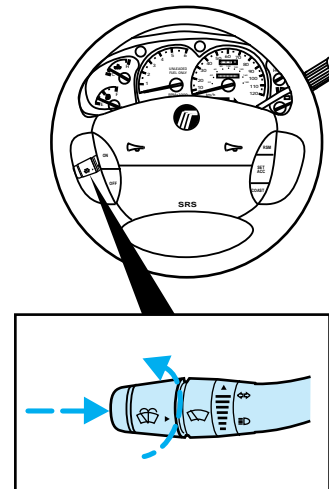

Controls and features

Activating high beams

Push the lever forward to activate the high beam lamps. Pull the lever towards you to activate the “flash to pass” function.

Push the lever down to activate the left turn signal.

Push the lever up to activate the right turn signal.

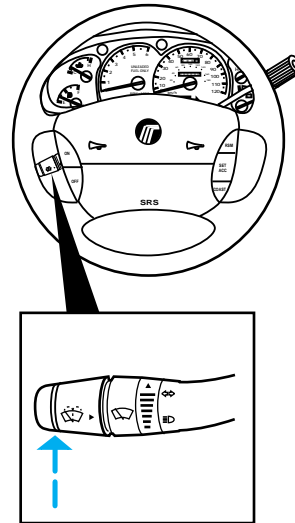

Controls and features

Overdrive control

Activating overdrive

Overdrive $\text{\textcircled{D}}$ is the normal drive position for the best fuel economy and will remain on until overdrive is deactivated.

The overdrive function allows automatic upshifts to 2nd, 3rd, and 4th gear.

Deactivating overdrive

Press the transmission control switch on the end of the gearshift lever. The transmission control indicator light (TCIL) $\frac{\text{O/D}}{\text{OFF}}$ will illuminate on the instrument cluster.

Transmission will operate in gears 1-3. To return to normal overdrive mode, press the transmission control switch again. $\frac{\text{O/D}}{\text{OFF}}$ will turn off.

When starting your vehicle, the transmission will automatically return to normal overdrive mode.

Deactivate overdrive when:

- driving with a heavy load
- driving in hilly areas
- additional engine braking is desired

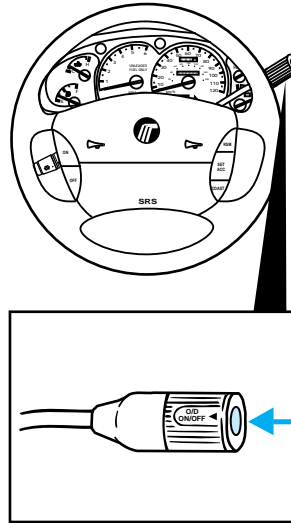

Controls and features

Hazard flasher

Push the hazard flasher button.
The button will pop out and the lamps will begin to flash.

To stop the flashers, push the
flasher button again.

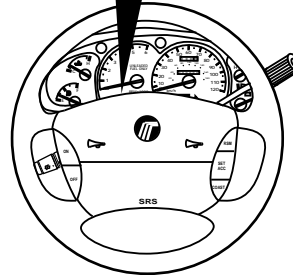
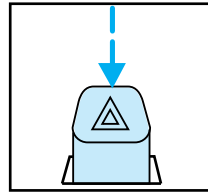

Tilt steering

 Never adjust the steering
column while the vehicle is
moving.

Pull the tilt steering lever towards
you and move the wheel to the
desired position.

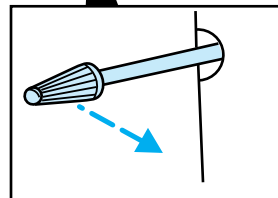
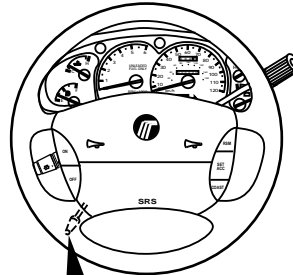

Controls and features

OVERHEAD CONTROLS

Overhead console (if equipped)

The console includes:

- compass/temperature display
- map lamps
- storage compartment
- garage door opener actuator
- moon roof control (if equipped)

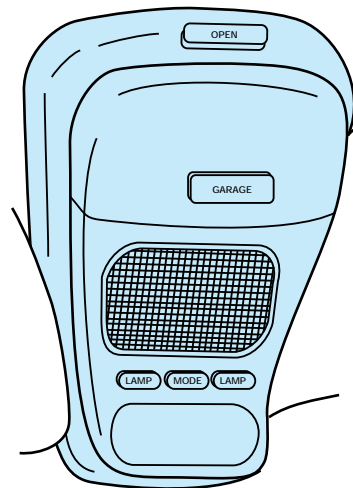

Controls and features

Compass/temperature display

Press the MODE button (with the ignition key in the ON position) to switch between the following features:

- display off
- temperature in C (Celsius) and compass
- temperature in F (Fahrenheit) and compass

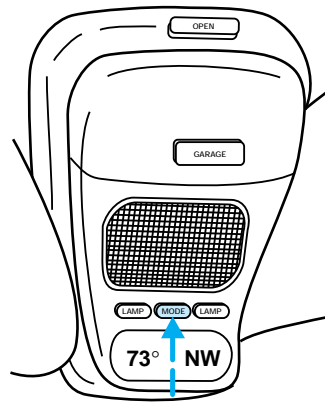

If the outside temperature is below 4°C (39°F), the word ICE will flash alternately with the temperature for one minute.

Compass accuracy can be affected when driving by large buildings, bridges, power lines, and powerful antennas. Compass accuracy can also be affected by magnetic objects placed in or on the vehicle.

There are two types of compass adjustments: zone and calibration.

Controls and features

Compass zone adjustment

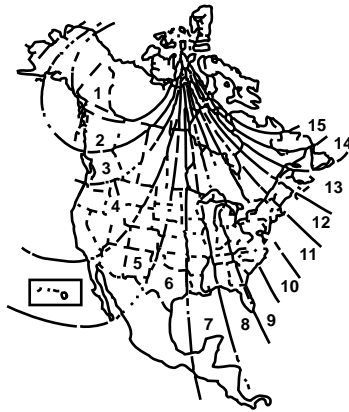

1. Determine which zone of the country you live in by referring to the zone map.
2. Press and hold the MODE button until VAR appears in the display; then release. The display will show the current zone number.
3. Press the MODE button until the desired zone number appears. Wait three seconds. The display will flash and then return to normal operation. Zone is now updated.

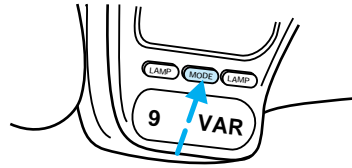

Compass calibration adjustment

Perform this adjustment in an open area free from steel structures and high voltage lines.

Controls and features

1. Press and hold the MODE button until CAL appears in the display (approximately eight seconds); then release.
2. Drive the vehicle slowly (less than 5 km/h/3 mph) in circles until the CAL indicator turns off (2-3 complete circles).

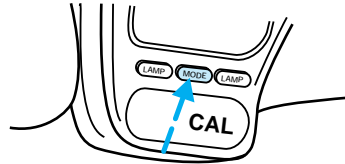

Map lamps

Press either the driver or passenger button to turn map lamps on or off.

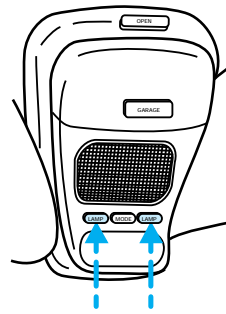

Storage compartment (if equipped)

Press the OPEN button to open the storage compartment. The door will open slightly and can be moved to full open.

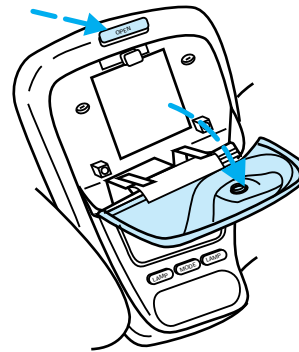

Installing a garage door opener

The storage compartment can be converted to activate a variety of aftermarket garage door openers.

Controls and features

1. Remove storage clip from door.
2. Place Velcro™ hook onto side of aftermarket transmitter opposite of actuator button.

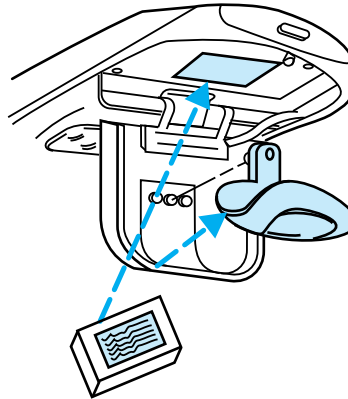

3. Place transmitter into storage compartment, button down.
4. Place the provided height adapters onto the back side of the GARAGE button as needed.

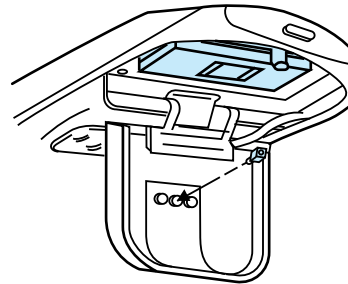

5. Press the GARAGE button to activate the transmitter.

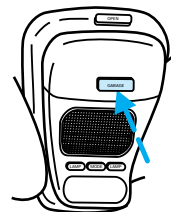

Controls and features

Moon roof (if equipped)

Press and hold bottom portion of moon roof switch to open.

Press and hold top portion of moon roof switch to close.

To raise the rear of the moon roof, close the moon roof and press top of rocker switch again. Press bottom of rocker switch to close it.

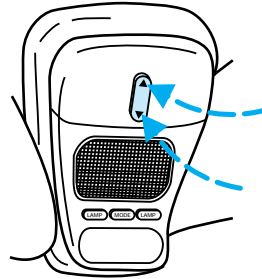

Autolamp delay system and automatic dimming mirror (if equipped)

Autolamp

The autolamp sets the headlamps to turn on and off automatically.

You can set the autolamp to:

- turn on the lamps automatically at night
- turn off the lamps automatically during daylight
- keep the lamps on for up to three minutes after you turn the key to OFF

Setting autolamp

1. Make sure the headlamp switch is in the OFF position. If the headlamp switch is on, you override the autolamp.
2. Turn the ignition key to ON or start your vehicle.

Controls and features

3. Slide the delay slide knob to the center of travel. The further you move the knob to the right, the longer the headlamps stay on after the ignition is turned to the OFF position. The autolamp will keep the headlamps on for a maximum of three minutes after the ignition is turned off.

4. The autolamp automatically turns the lamps on and off.

Automatic dimming feature

The autolamp/automatic dimming mirror is equipped with an automatic dimming feature. This feature will change from the normal state to the non-glare “active” state when bright lights (glare) reach the mirror. When the mirror detects bright light from the front or behind, it will adjust automatically to minimize glare.

The automatic dimming feature is active when the ignition is turned to the ON position.

When active, the mirror senses bright light (glare) from the front and rear and automatically adjusts itself to minimize glare.

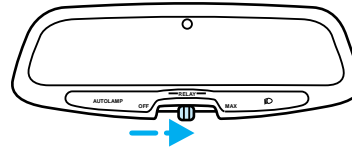

Controls and features

DOOR MOUNTED CONTROLS

Power windows

Driver side control

Press and hold rocker switch to close driver window.

Press and release rocker switch for partial window movement.

The driver side power window has a one touch down feature. When the AUTO switch is fully pressed, the driver side window will move completely down. This feature can be canceled by pressing the driver side power window button again.

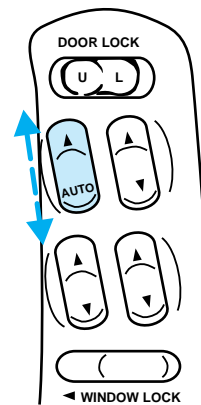

Press rocker switch to open the passenger window.

Press rocker switch to close the passenger window.

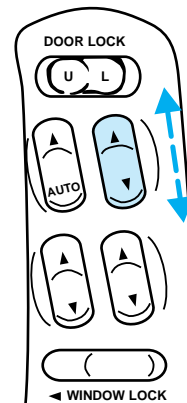

Controls and features

Press rocker switch to open the rear passenger window(s).

Press rocker switch to close the rear passenger window(s).

Your vehicle has a power window lock feature. When the power window lock feature is enabled, the passenger and the rear seat power windows cannot be operated by passengers.

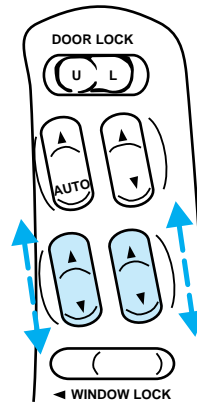

Press rocker switch to enable power window lock.

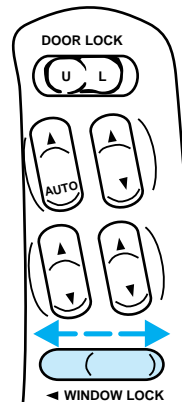

Controls and features

Passenger side control

Press rocker switch to open window.

Press rocker switch to close window.

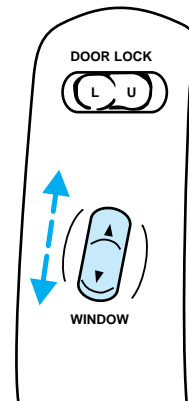

Rear seat passengers

Press rocker switch to open right rear window.

Press rocker switch to close right rear window.

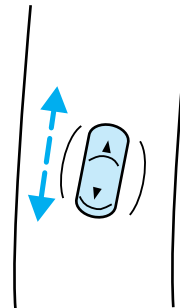

Press rocker switch to open left rear window.

Press rocker switch to close left rear window.

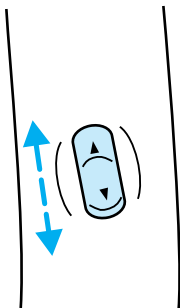

Controls and features

Power locks

Driver side

Press U once to unlock all doors and liftgate.

Press L once to lock all doors and liftgate.

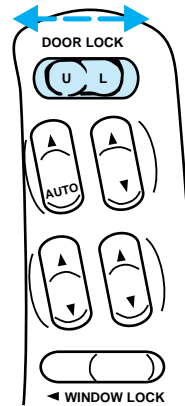

Passenger side

Press U once to unlock all doors and liftgate.

Press L once to lock all doors and liftgate.

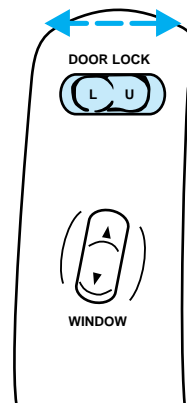

Controls and features

Rear liftgate

Press rocker switch (key graphic) once to unlock all doors and liftgate.

Press opposite side to lock all doors and liftgate.

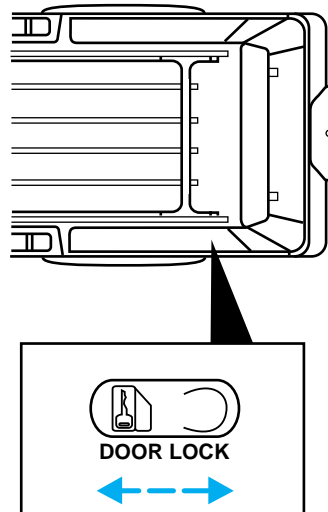

Childproof locks for rear doors

When you set these locks, the rear doors cannot be opened from the inside. The rear doors can still be opened from the outside when the lock knobs are raised.

Controls and features

Move lever to LOCK position (up) to set the lock.

Move lever to UNLOCK position (down) to disengage the lock.

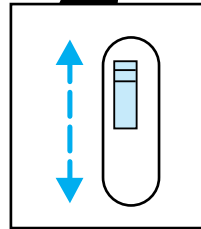
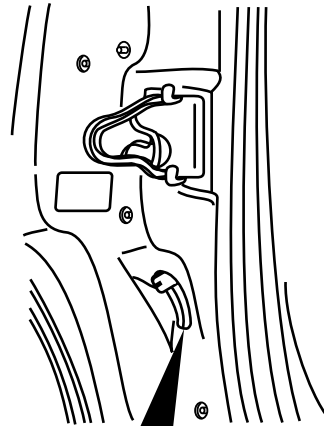

Two-step unlock feature (if equipped)

This feature allows you to unlock all vehicle doors with the key.

1. Unlock driver door.

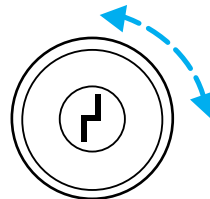

2. Repeat unlock procedure within 4 seconds. All doors and

Controls and features

liftgate will unlock when the key is returned to the vertical position (position of key before removal).

This feature can be activated by all outside locks on vehicles equipped with keyless entry.

Illuminated entry

Interior lamps illuminate when either outside front door handle is lifted, unlocked with the keyless entry keypad or the UNLOCK button is pressed on the remote entry transmitter (see *Remote entry system* or *Keyless entry system* for further information).

The system will automatically turn off after 25 seconds or when the ignition switch is turned to START or ON position.

The inside lights will not turn off if you have turned them on with the dimmer thumbwheel or if any door is open. However, the battery saver will turn them off after ten minutes. See *Battery saver* for more information.

Controls and features

Power mirrors

1. Select driver or passenger mirror by moving selector lever left for driver or right for passenger.
2. Move the mirror control knob until mirror reaches desired position.
3. Return the selector lever to the center "off" position.

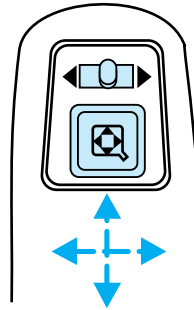



CONSOLE CONTROLS

Center console

Your vehicle has a center console that is equipped with the following features:

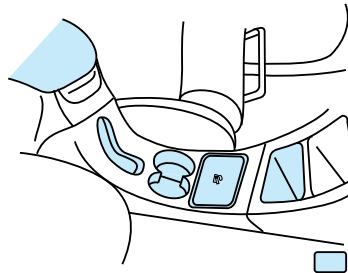
- Auxiliary power point
- Utility compartment
- Ashtray
- Cupholders
- Tissue tray
- Utility compartment with cassette/compact disc storage and coinholder
- Compact disc changer (if equipped)



 Use only soft cups in the cupholder. Hard objects can injure you in a collision.

Controls and features

Auxiliary power point

This power point is an additional power source for electrical accessories.

 Do not plug optional electrical accessories into the cigarette lighter. Use the power point.

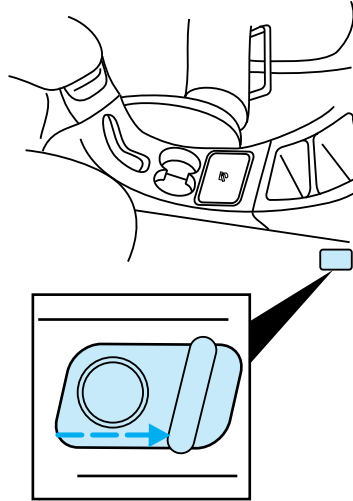

Replacing the tissue box

1. Lift armrest and slide coinholder/tissue box out of console in an upward motion.
2. Replace tissue box.
3. Slide coinholder/tissue tray into console locating pins at bottom of tray. Fit in slots in console bracket.

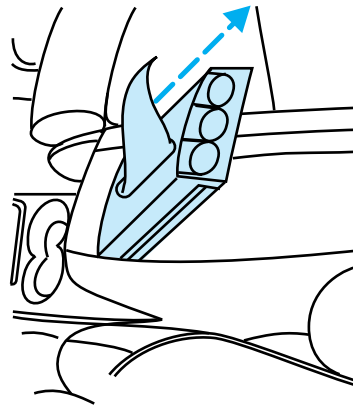

Controls and features

Rear console (if equipped)

Your vehicle is equipped with a rear console that includes the following features:

1. Air vents
2. Audio system controls (refer to *Audio Guide*)
3. Rear seat climate control direction and fan controls
4. Cupholders

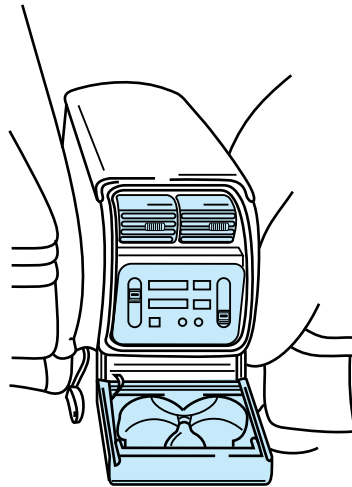

Controls and features

Rear climate controls

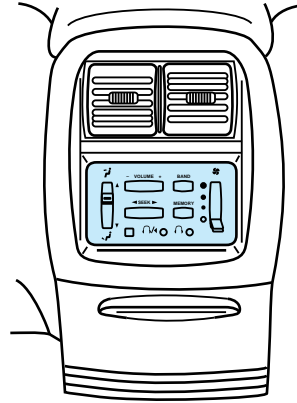

Turn the air distribution dial to the desired airflow position.

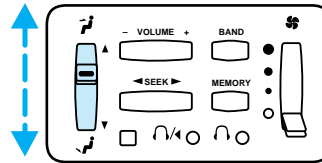

Turn the fan speed dial to the desired position.

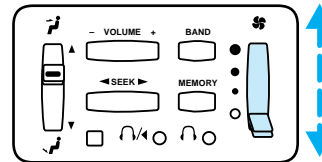

Controls and features

Controlling airflow

Select  for air to flow through these vents:

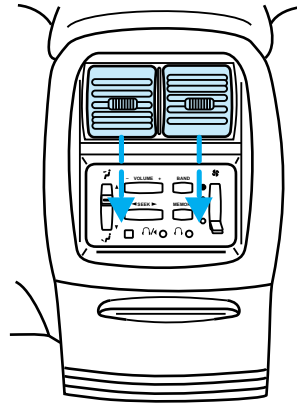

Select  for air to flow through these vents:

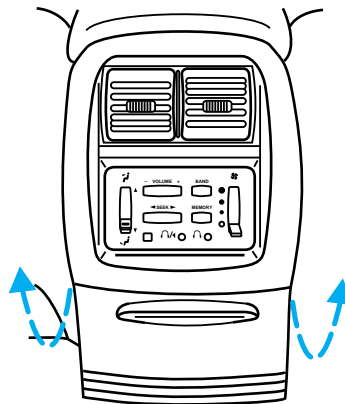

Cargo area controls

Cargo cover (if equipped)

Your vehicle is equipped with a cargo shade that covers the luggage compartment of your vehicle.

Controls and features

Installing shade

1. Position shade in mounting brackets as shown (tongue faces rear of vehicle).
2. Pull end of shade towards you and hook sides into notches in rear trim panels.

 To avoid possible injury during a sudden stop or collision, the cover should be attached to the brackets when not in use.

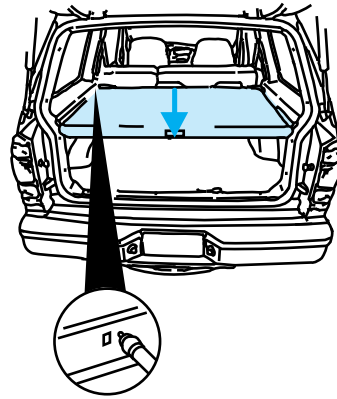

Rewinding shade to regain lost tension

Over time, the cargo shade may lose its spring tension. If this happens, then follow these instructions to rewind the shade. You will need the help of another person.

1. Remove the shade from the side anchor slots by compressing telescoping tube. Extend the shade fully. Make sure smooth grain is facing you.
2. Wrap the vinyl around the roller tube twice. Tuck the edges of the vinyl inside the end cap with each wrap.

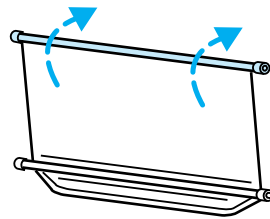

Controls and features

3. Fold vinyl edges towards center, making sure that the edges clear the end cap slots. Use tape or rubber band to hold the vinyl on the left side of the roller tube.

4. While holding the vinyl and roller tube, push in the right end cap (marked RH) about 6.4 mm (1/4 inch) to disengage the clutch. Hold end cap in while turning roller tube towards you 14 times.

5. Let go of the right end cap. The clutch should now engage and stop the shade from losing its spring tension.

6. Unfold the vinyl and place it into the end cap slots.

7. Insert the shade into the side mounting brackets (the opening for the right mounting bracket is narrower than the left). Check to see if the shade operates properly.

Spare tire and jack

Your vehicle is equipped with a full-size spare tire located behind the rear bumper. For instructions on how remove and mount the spare tire, refer to the *Roadside emergencies* section later in this Owner's Guide.

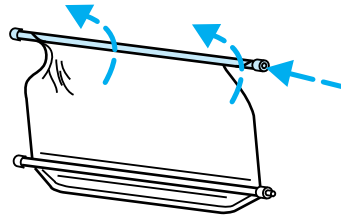

Controls and features

Keyless entry system (if equipped)

With the keyless entry keypad, you can:

- lock or unlock the vehicle doors and liftgate without using the key.
- arm and disarm the anti-theft system.

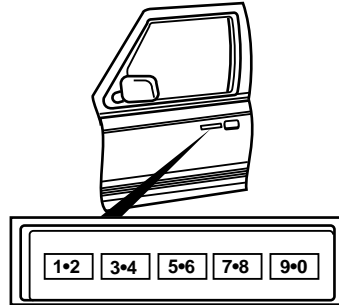

See also *Remote entry system* and *Anti-theft system* later in this chapter for more information.

Your vehicle has a factory-set 5-digit code that operates the keyless entry system. You can also program your own 5-digit personal entry code. The factory-set code is located in:

- the owner's wallet card in the glove compartment
- taped to the computer module

Programming personal entry code

1. Enter factory-set code (keypad will illuminate when pressed).
2. Press 1/2 within five seconds of Step 1.
3. Enter your personal 5-digit code. Enter each digit within five seconds of the previous one.

Do not set a code that includes five of the same number or

Controls and features

presents them in a sequential order.

Press the middle of the buttons (there is only one switch under each button).

You can use either code to unlock your vehicle. If a second personal code is entered, the module will erase the old code in favor of the new code. If you wish to erase your personal code, use the following instructions:

Erasing personal code

1. Enter factory-set code.
2. Press 1/2 within five seconds of Step 1.
3. Wait six seconds.

The system will now only respond to the factory-set code.

Unlocking the doors with the keyless entry system

1. Enter either factory-set code or personal code. Driver door will unlock and interior lamps will illuminate.
2. Press 3/4 button within five seconds of unlocking driver door. Passenger doors and liftgate will unlock.

If five seconds expire, you must re-enter code, then press 3/4 button to unlock all doors.

Locking doors with keyless entry system

It is not necessary to enter the factory or personal code prior to

Controls and features

locking the doors and liftgate. To lock the doors:

- press 7/8 and 9/0 buttons at the same time.

This will arm your anti-theft system; see *Arming anti-theft system with keyless entry* and *Anti-theft system* later in this chapter for more details.

Arming anti-theft system with keyless entry

To arm the anti-theft system:

- press 7/8 and 9/0 buttons at the same time.

To disarm the anti-theft system:

- enter either the factory-set code or your personal code.

Doors, liftgate, and liftgate window must be fully closed for the anti-theft system to arm. See *Anti-theft system* for more details.

Autolock

Autolock is a feature of the keyless entry system and is enabled at the factory. Autolock will automatically lock all doors and liftgate when:

- all vehicle doors, liftgate, and liftgate window are closed.
- ignition switch is in the ON position.
- brake pedal is pressed.
- you shift through R (Reverse).
- brake pedal is released.

Controls and features

Relock

The autolock feature will repeat when:

- any door is opened and closed.
- the brake pedal is released.

Deactivating autolock

Before following the activation or deactivation procedures, make sure that the anti-theft system is not armed, ignition is off, and all vehicle doors and liftgate window are closed.

1. Enter five-digit entry code.
2. Press and hold 7/8 button.
3. Press and release 3/4 button while holding 7/8 button.
4. Release 7/8 button.

To re-activate autolock, repeat Steps 1-4.

Remote keyless entry system (if equipped)

The remote entry system allows you to lock or unlock all vehicle doors without using a key.

The remote entry system also arms and disarms the anti-theft system (see *Anti-theft system* later in this chapter for more information).

The remote entry system only operates with the ignition in the OFF position.

Your vehicle is equipped with two transmitters. The system will work with up to four transmitters.

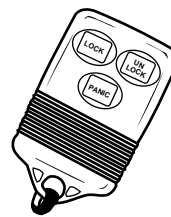

Controls and features

Additional transmitters can be ordered from your dealer.

Unlocking the doors with the remote entry system

Press UNLOCK button to unlock driver door. The interior lamps will illuminate.

Press UNLOCK a second time within 5 seconds to unlock all doors and liftgate.

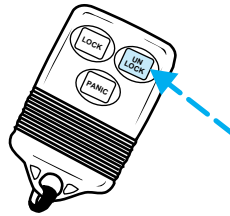

Locking the doors with the remote entry system

Press the LOCK button to lock all doors and liftgate.

Press the LOCK button a second time within 5 seconds to confirm that all doors and liftgate are locked.

The doors will lock again, the horn will chirp, and the lamps will flash.

This will arm your anti-theft system. If the horn chirps twice, a door is still ajar and the anti-theft system will not arm. See *Anti-theft system* for more details.

Remote entry personal alarm

The remote entry personal alarm feature allows you to activate the alarm. When activated, the horn will honk and the lights will flash.

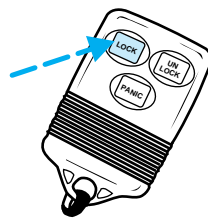

Controls and features

Press the PANIC button to activate the alarm.

To turn off the alarm, press the PANIC button again or turn the ignition key to the ON or ACC position.

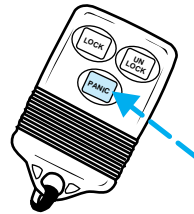

This device complies with Part 15 of the FCC rules. Operation is subject to the following two conditions: (1) This device may not cause harmful interference, and (2) This device must accept any interference received, including interference that may cause undesired operation.

Replacing the batteries

If you notice a decrease in operating range, replace the transmitter batteries. Replacement batteries can be purchased at most pharmacies or through your Ford or Lincoln-Mercury dealer. The transmitter is powered by two coin type three-volt lithium 2016 batteries.

The operating range of the remote entry transmitters can also be affected by adverse weather conditions, nearby radio/tv towers, or large structures around the vehicle. Typical operating range is up to 10 meters (33 feet).

Opening the transmitter

Insert and twist a thin coin between the two halves of the transmitter; the transmitter will snap apart.

Controls and features

When installing new batteries, be sure to place the positive (+) side down as marked. Snap the two halves back together.

Replacing lost transmitters

If a transmitter is lost, take your vehicle's transmitter to the dealer to have the remote entry system deprogrammed for the lost transmitter. This will prevent unauthorized use of the lost transmitter.

You can purchase additional transmitters (up to four can be used) from your dealer. Use the following instructions to re-program the key fobs.

Re-programming your key fob(s)

1. Insert key into ignition.
2. Rotate key to ON five times. DO NOT START THE ENGINE. Keep key in ON position the fifth time.

Locks will lock/unlock by themselves.

3. Push UNLOCK on first key fob. Doors will lock/unlock to indicate key fob has been programmed.
4. Repeat Step 3 for each key fob to be re-programmed.
5. Turn ignition key to OFF. Verify each transmitter has been programmed by activating any button.

Controls and features

Anti-theft system (if equipped)

When set, the anti-theft system protects against unauthorized entry into a locked vehicle.

The ignition switch must be in the OFF position to arm the anti-theft system.

Arming the anti-theft system

Use one of the following methods to arm the system:

- Press the LOCK button on the remote entry transmitter (with doors open or closed).

OR

- Open any door and press the power lock button.

OR

- Press the 7/8 and 9/0 buttons on the keyless entry keypad (see *Keyless entry system* for more information).

Identifying system indicators

While the system is arming, the THEFT indicator will illuminate for 30 seconds. After 30 seconds, the THEFT indicator will flash.

If the system is armed with the doors open, THEFT will stay illuminated until all doors are closed. After all doors are closed, it will illuminate for 30 seconds and then start flashing.

When an unauthorized entry occurs, the system activates and will:

Controls and features

- flash the headlamps, park lamps and the **THEFT** indicator in the instrument cluster.
- sound the horn.
- disable vehicle starting.

The flashing exterior lamps and honking horn will shut off automatically after about 3 minutes. The lights and horn will remain off unless another unauthorized entry is attempted. However, the vehicle will not start until the system is properly disarmed.

How to disarm the system

To cancel an armed system, you must:

- press the UNLOCK button on the remote entry transmitter.

OR

- unlock any door with the key.

OR

- turn the ignition switch to the ON position.

OR

- unlock the doors by entering the unlock code into the keyless entry keypad.

How to deactivate a triggered system

To immediately cancel an activated system, press the PANIC button on the remote entry transmitter.

A triggered system can also be deactivated by following the steps in *How to disarm the system*.

Controls and features

Delayed accessory

Delayed accessory provides power to operate the power windows and power moon roof (if equipped) for 10 minutes after the ignition switch is turned to OFF.

If either front door is opened during the 10 minute period the delayed accessory feature is disabled.

Battery saver

Battery saver is a feature that automatically shuts off power to these lights after 40 minutes: glove box, engine compartment, overhead console, mirror, courtesy and interior lamps.

Battery saver prevents the battery from being drained if these lights are left on or if a door is not completely closed. Battery power is restored if the remote entry transmitter is used, any door is opened, the liftgate is opened, or ignition key is turned to ON.

Seating and safety restraints

FRONT BUCKET SEATS

Adjusting manual seats

Lift to move the seat forward or backward.

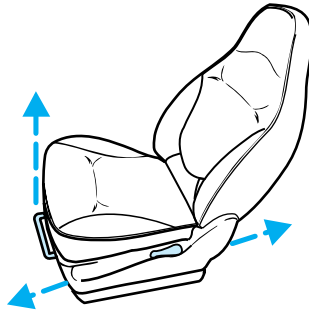

Pull up to recline the seat.

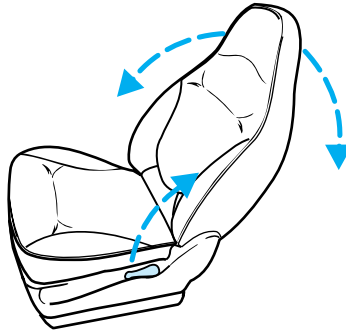

Seating and safety restraints

Adjusting power seats (if equipped)

Pull up to recline the seat.

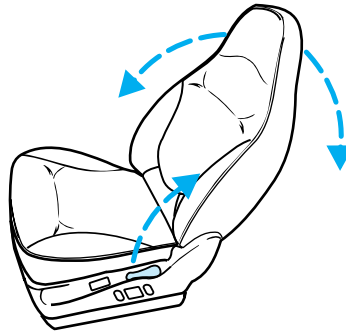

Press to tilt front and rear of seat up or down.

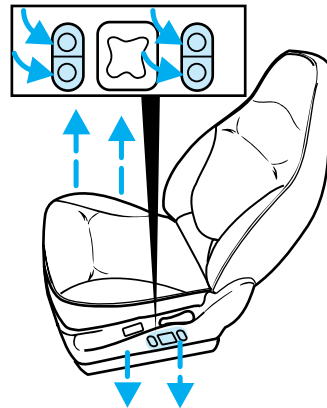

Seating and safety restraints

Press in the desired direction to raise or lower the seat, or to move the seat backward or forward.

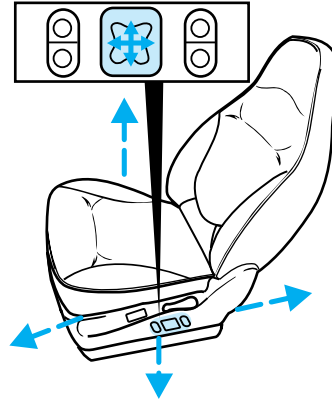

Push to increase (+) or decrease (-) lumbar support.

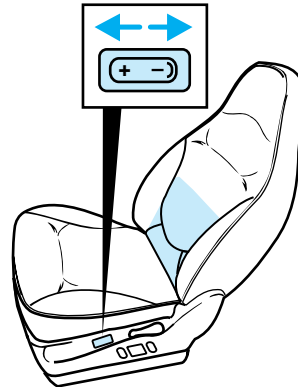

Seating and safety restraints

Rear seat four-way head restraints (if equipped)

Push the lock release button to raise or lower the head restraint.

Push or pull head restraint to desired position.

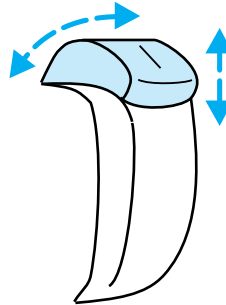

Folding rear seat

If your vehicle is equipped with a built-in child seat, the seatback cannot be folded down unless the built-in child seat is fully stowed.

1. Push the lower release handle downward to unlatch seat back.
2. Rotate seatback downward into the load floor position.

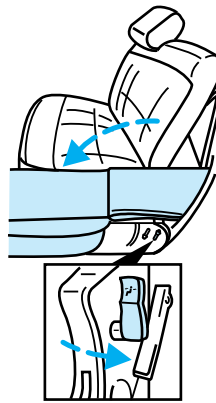

3. Push down on the top outboard area of the seatback until you hear a “click.” The seat is latched in the load floor position.

Seating and safety restraints

Return to upright

1. Push downward on upper outboard corner of seatback and hold.
2. Lift release handle upward to unlatch seat.
3. Rotate seatback upward until seatback latches in the upright position. You will hear a “click” when seatback locks.

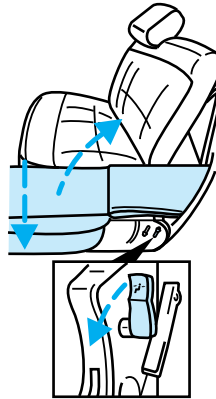

SAFETY RESTRAINTS PRECAUTIONS

The use of safety belts helps to restrain you and your passengers in case of a collision. In most states and in Canada the law requires the use of safety belts.

 To reduce the risk of serious injury in a collision, always drive and ride with your seatback upright and the lap belt snug and low across the hips.

 Safety belts must be worn by all vehicle occupants to be properly restrained and help reduce the risk of injury in a collision.

Seating and safety restraints

 To prevent the risk of injury make sure children sit where they can be properly restrained.

 It is extremely dangerous to ride in a cargo area, inside or outside of a vehicle. In a collision, people riding in these areas are more likely to be seriously injured or killed.

 Do not allow people to ride in any area of your vehicle that is not equipped with seats and safety belts.

 Be sure everyone in your vehicle is in a seat and using a safety belt properly.

USING THE SAFETY RESTRAINTS PROPERLY

Combination lap and shoulder belts

1. To connect the safety belt, insert the tongue into slot in the buckle.
2. To disconnect the safety belt, push the red release button and remove the tongue from the buckle.

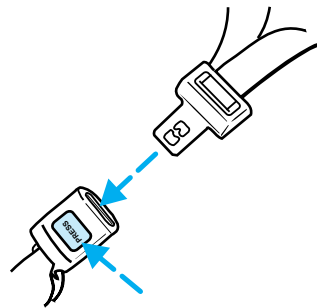

Seating and safety restraints

The outboard safety restraints in the vehicle are combination lap and shoulder safety belts. The front and rear seat passenger outboard safety belts have the two types of locking modes described below:

Vehicle sensitive (Emergency) locking mode

The vehicle sensitive mode is the normal retractor mode, allowing free shoulder belt length adjustment to your movement and locking in response to vehicle movement. For example, if the driver brakes suddenly, turns a corner sharply, or the vehicle receives an impact of 8 km/h (5 mph) or more the combination safety belts will lock to help reduce forward movement of the driver and passengers.

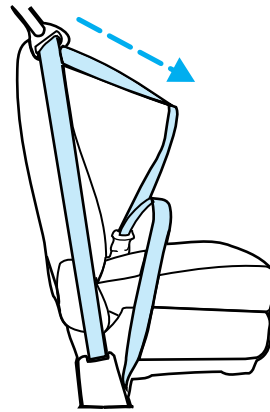

The front seat belt system can also be made to lock manually by quickly pulling on the shoulder belt. Rear seat belts cannot be made to lock up by pulling quickly on the belt.

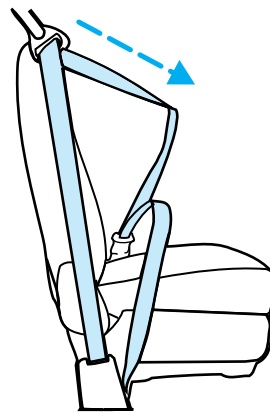

Seating and safety restraints

Automatic locking mode

In this mode, the shoulder belt is automatically pre-locked; however, the belt will still retract to remove any slack in the shoulder belt.

The automatic locking mode is not available on the driver safety belt.

When to use the automatic locking mode

- When a tight lap/shoulder belt fit is desired.
- **Any time** a child safety seat is installed in the vehicle. Refer to *Children and infant or child safety seats* later in this section.

How to use the automatic locking mode

1. Buckle the combination lap and shoulder belt.

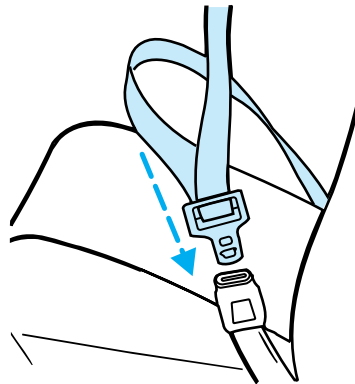

Seating and safety restraints

2. Grasp the shoulder belt portion and pull downward until the entire belt is extracted.

3. Allow the belt to retract. As the belt retracts, you will hear a clicking sound. This indicates that the safety belt is now in the automatic locking mode.

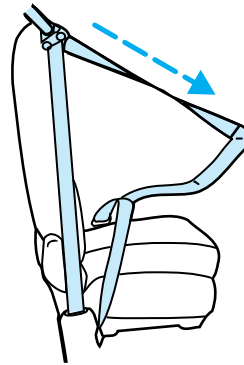

How to cancel the automatic locking mode

Disconnect the combination lap/shoulder belt and allow it to completely retract to cancel the automatic locking mode and activate the vehicle sensitive (emergency) locking mode.

Front seat safety belt height adjustment

Your vehicle has safety belt height adjustments for the driver and passenger seating positions.

Adjust the height of the shoulder belt so the belt rests across the middle of your shoulder.

Seating and safety restraints

1. To lower shoulder belt height, push the button and slide down.
2. To raise the height of the shoulder belt, push the button and slide up.
3. Pull down on the height adjustment assembly to make sure it is locked in place.

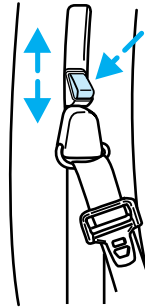

Center rear lap belt

The center rear seating position has a lap belt with retractor.

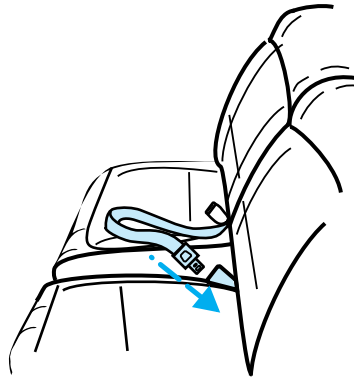

To unfasten the safety belt:

1. Push the release button on the buckle. This allows the tongue to unlatch from the buckle.
2. While the belt retracts, guide the tongue to its stowed position. If you do not guide the tongue, it may strike you or part of the vehicle.

Seating and safety restraints

SAFETY BELT WARNING AND INDICATOR CHIME

The  warning light illuminates in the instrument cluster and a chime sounds to remind the occupants to fasten their safety belts.

Conditions of operation

If...	Then...
The safety belt is not buckled before the ignition key is turned to ON...	The safety belt indicator light illuminates for one to two minutes and the warning chime sounds for 4-8 seconds.
The safety belt is buckled while the indicator light is illuminated and the warning chime is sounding...	The safety belt indicator light and the warning chime turn off.
The safety belt is buckled before the ignition key is turned to ON...	Both the safety belt warning light and chime remain off.

SAFETY BELT MAINTENANCE

Check the safety belt systems periodically to make sure that they work properly and are not damaged. Check the safety belts to make sure there are no nicks, wear, or cuts. If your vehicle has been involved in an accident, have all the safety belts and child seat anchoring brackets (if equipped) examined by a qualified technician.

Seating and safety restraints

Energy absorbing sew pattern

The short plastic boot on the front passenger safety belt covers an energy absorbing sew pattern on the safety belt. In the event of an accident, the sew pattern may release, and the orange REPLACE BELT label may become visible. If any part of the orange label is exposed, the belt must be replaced.

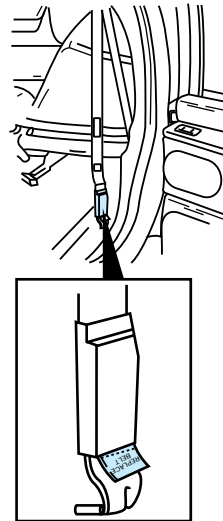

Failure to replace the safety belt assembly under the above conditions could result in severe personal injuries in the event of a collision.

Lincoln-Mercury recommends that all safety belt assemblies used in vehicles involved in a collision be replaced. However, if the collision was minor and a qualified technician finds that the belts do not show damage and continue to operate properly, they do not need to be replaced. Safety belt assemblies not in use during a collision should also be inspected and replaced if either damage or improper operation is noted.

Seating and safety restraints

Safety belt extension assembly

For some people, the safety belt may be too short even when it is fully extended. You can add about 20 cm (8 in) to the belt length with a safety belt extension assembly (part # 611C22). Safety belt extensions are available at no cost from your dealer.

Use only extensions manufactured by the same supplier as the safety belt. Manufacturer identification is located at the end of the webbing on the label. Also, use the safety belt extension only if the safety belt is too short for you when fully extended. Do not use extension to change the fit of the shoulder belt across the torso.



Failure to follow these instructions will affect the performance of the safety belts and increase the risk of personal injury.

Cleaning the safety belts

Clean the safety belts with a mild soap solution recommended for cleaning upholstery or carpets. Do not bleach or dye the belts, because these actions may weaken the belt webbing.

AIR BAG PRECAUTIONS

Your vehicle is equipped with an air bag supplemental restraint system (SRS) designed to work with safety belts to help protect you and your right front seat

Seating and safety restraints

passenger in the event of a collision.

 All occupants of the vehicle, including the driver, should always wear their safety belts, even when an air bag supplemental restraint system is provided.

 Do not place objects or mount equipment on or near the air bag cover on the steering wheel or in front seat areas that may come into contact with a deploying air bag. Failure to follow this instruction may increase the risk of personal injury in the event of a collision.

 Do not attempt to service, repair, or modify the air bag supplemental restraint system or its fuses. See your Ford or Lincoln-Mercury dealer.

 Rear-facing child seats or infant carriers should never be placed in the front seat.

Air bags and air bag equipped vehicles should be disposed of only by your dealer.

Seating and safety restraints

AIR BAG DESCRIPTION

The air bag system activates in collisions more severe than hitting a parked vehicle of similar size and weight head-on at about 45km/h (28 mph).



The air bag system consists of two parts:

- The driver air bag in the middle of the steering wheel and the passenger air bag near the glove compartment.
- The electrical system, made up of impact sensors, a diagnostic module, and a backup power supply.

The diagnostic module monitors its own internal circuits and the supplemental air bag electrical system readiness (including the impact sensors), the system wiring, the air bag system readiness light, the air bag back up power, and the air bag igniters.

The air bags inflate within a fraction of a second after air bag sensors detect a severe frontal collision. Gas generators within the air bags fill the air bags with a non-toxic, non-flammable gas. After the vehicle occupants have contacted the air bags, the gas empties through holes in the air

Seating and safety restraints

bags, and the air bags deflate. You may notice smoke and smell the escaping gas after the air bags deflate. This is normal.

You and your passenger must wear your safety belts in order for the air bag system to operate effectively.

AIR BAG WARNING LIGHT AND CHIME

When you turn the ignition key to the ON position, the  warning light in the instrument cluster illuminates for approximately six seconds to indicate the air bag system is functional.

If you hear a group of five beeps, or if the  warning light does not illuminate, stays lit, or flashes, the air bag system requires immediate service. Have the vehicle serviced at your dealer.

CHILD RESTRAINT PRECAUTIONS

You are required by law to use safety restraints in the United States and Canada. If small children ride in your vehicle (generally children who are four years of age or younger and who weigh 18 kg [40 lb or less]), you must put them in safety seats made especially for children. Check your local and state laws for specific requirements regarding the safety of your children.

Seating and safety restraints



Never let a passenger hold a child on his or her lap while the vehicle is moving. The passenger cannot protect the child from injury in a collision.

Always follow the instructions and warnings that come with any infant or child restraint you might use.

If possible, place children in the rear seat of your vehicle. Accident statistics suggest children are safer when properly restrained in rear seating positions than in the front seating positions.

CHILDREN AND SAFETY BELTS

Children who are too large for child safety seats (as specified by the manufacturer of your child safety seat) should always wear their safety belts.

Follow all the important safety restraint and air bag precautions that apply to adult passengers in your vehicle.

If the shoulder belt portion of a combination lap and shoulder belt can be positioned so it does not cross or rest in front of the child's face or neck, the child should wear the lap and shoulder belt. Moving the child closer to the center of the vehicle may help to provide a good shoulder belt fit.

If the shoulder belt cannot be properly positioned:

- Move the child to a seat with a lap belt only.

Seating and safety restraints

OR

- If the child is the proper size, restrain the child in a safety seat.

CHILDREN AND INFANT OR CHILD SAFETY SEATS

 Carefully follow all of the manufacturer's instructions included with the safety seat you put in your vehicle. If you do not install and use the safety seat properly, the child may be injured in a sudden stop or collision.

When installing a child safety seat:

- Use the correct safety belt buckle for that seating position.
- Make sure the tongue is securely fastened in the buckle.
- Keep the buckle release button pointing up and away from the safety seat, with the tongue between the child seat and the release button, to prevent accidental unbuckling.
- Place seatbacks in the upright position.
- Put the safety belt in the automatic locking mode. Refer to *How to use the automatic locking mode*.

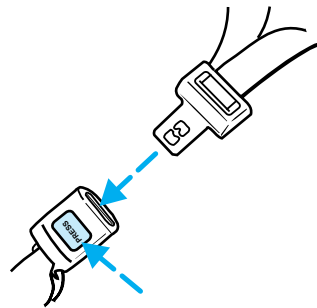

Seating and safety restraints

Installing child safety seats in combination lap and shoulder belt seating positions

1. Position the child safety seat in a seat with a combination lap and shoulder belt.

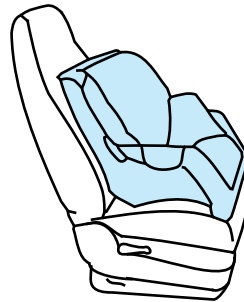

If you choose to install a child safety seat in the front passenger seat, move the seat as far back as possible.



Rear-facing child seats or infant carriers should never be placed in the front seat.

2. Pull down on the shoulder belt and then grasp the shoulder belt and lap belt together.

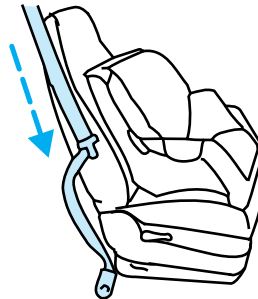

Seating and safety restraints

3. While holding the shoulder and lap belt portions together, route the tongue through the child seat according to the child seat manufacturer's instructions. Be sure the belt webbing is not twisted.

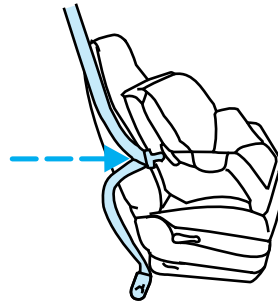

4. Insert the belt tongue into the proper buckle for that seating position until you hear and feel the latch engage. Make sure the tongue is latched securely by pulling on it.

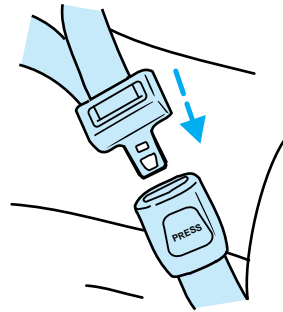

5. Grasp the shoulder portion of the belt and pull downward until all of the belt is extracted and a click is heard to put the retractor in the automatic locking mode.

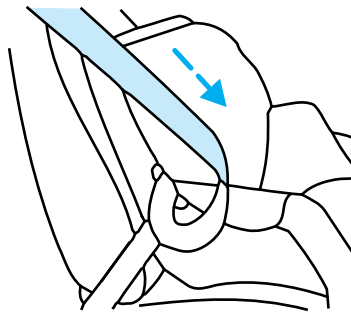

6. Allow the belt to retract. The belt will click as it retracts to indicate it is in the automatic locking mode.

Seating and safety restraints

7. Pull the lap belt portion across the child seat toward the buckle and pull up on the shoulder belt while pushing down on the child seat.

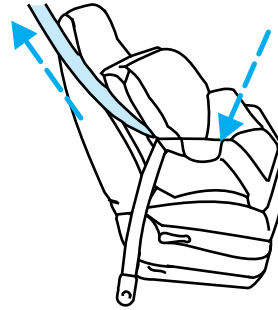

8. Allow the safety belt to retract to remove any slack in the belt.

9. Before placing a child in the seat, forcibly tilt the seat forward and back to make sure the seat is securely held in place.

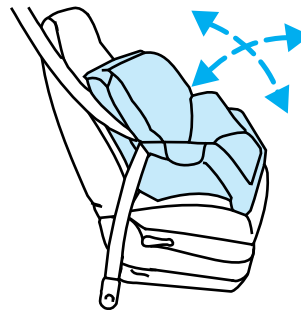

10. Try to pull belt out of the retractor to make sure the retractor is in the automatic locking mode (you should not be able to pull more belt out). If the retractor is not locked, unbuckle the belt and repeat Steps 2 through 9.

Check to make sure the child seat is properly secured before each use.

Using a tether strap

Ford recommends using child safety seats with a top tether

Seating and safety restraints

strap. Contact the manufacturer of your safety seat for information about ordering a tether strap if one is not provided to you. Contact your Ford dealer for a free tether anchor kit (613D74) so you can attach a tether anchor bracket to the tether anchor attachment locations in the rear floor. Carefully follow the instructions provided with the kit.



Only use the tether attachment hole locations shown. The tether anchor may not perform properly if the wrong mounting location is used.

Follow the child seat manufacturer's instructions for installing a child seat with a tether strap.

Ford recommends you attach tethered safety seats in a rear seating position with the tether strap attached to the tether anchoring bracket as shown in the instructions provided with the tether anchor kit.

If a tethered seat must be installed in the front passenger seat:

1. Buckle the safety belt in the seat directly behind the front passenger seat.
2. Place the rear safety belt in the automatic locking mode. Refer to *How to use the automatic locking mode* in this chapter.
3. Install the child safety seat in the front seat. Refer to the

Seating and safety restraints

instruction under *Installing child safety seats in combination lap and shoulder belt seating positions* in this chapter.

4. Hook the tether strap around the webbing near the center of the shoulder portion of the rear safety belt and tighten.

BUILT-IN CHILD SEAT (IF EQUIPPED)

The rear seat may include a built-in child seat. This child seat conforms to all federal and Canadian motor vehicle safety standards. Read the labels located on the child seat cushion and shoulder belt for information on the built-in child seat.

Use the built-in child seat **only** under the following conditions:

Child's Age	Child's Weight	Child's Height
At least 1 year	10-27 kg (22-60 lb)	Shoulders must be below the shoulder harness slots on the built-in child seat

Children not meeting these requirements should be secured in an approved aftermarket child seat. Refer to *Children and infant or child safety seats* in this chapter.

Seating and safety restraints

Placing your child in the built-in child seat

 Failure to follow all of the instructions on the use of this child restraint system can result in your child striking the vehicle's interior during a sudden stop or crash.

 Never use the built-in child seat as a booster cushion with the adult safety belts. A child using the adult belts could slide forward and out from under the safety belts.

 The rear seatback must be fully locked before operating the child restraint system.

1. Grasp the pull strap and pull toward you approximately one inch, then slide hand under head restraint and slide upwards to full position.

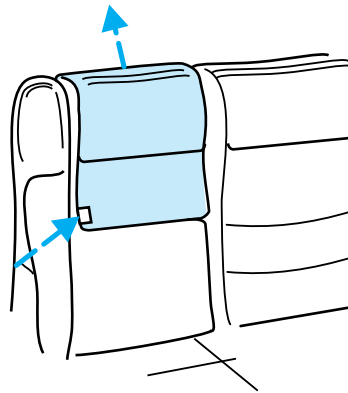

Seating and safety restraints

2. Pull both Velcro® straps to release child seat cushion.

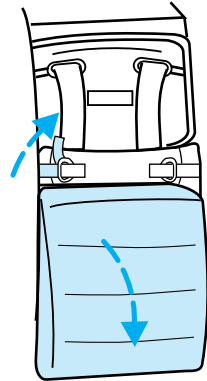

3. Lower child seat cushion.



Seating and safety restraints

4. Unfold cushion protector flap onto adult seat cushion.

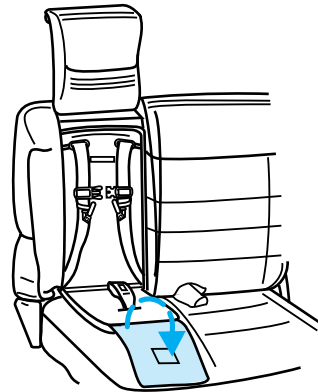

5. If connected, disconnect the chest clip and buckles.

6. Place the child in the seat and position the left shoulder belt over the child's left shoulder first, then place the right shoulder belt over the child's right shoulder.

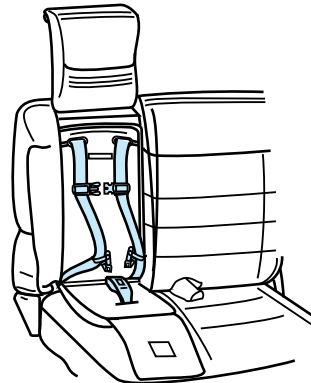

Seating and safety restraints

7. Insert the left and right safety belt tongues into the left and right slots of the crotch buckle. Verify that the indicator window on each tongue is green to ensure proper safety belt connections.

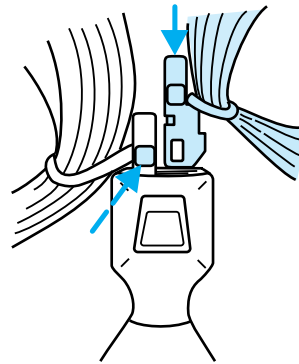

 If both tongues do not latch in the buckle, do not use the child seat. See your dealer for repairs.

8. Fasten the left and right chest clip halves together, and adjust the clip (up or down) to comfortably hold the shoulder belts in place on the child's chest.

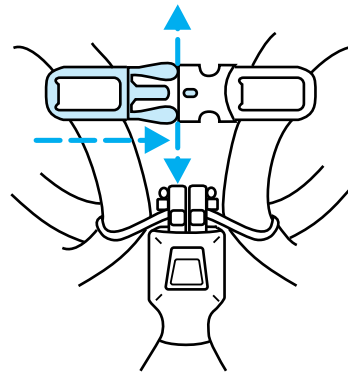

The chest clip is designed to easily pull apart in the event of an accident. The clip helps keep the belts on a squirming or sleeping child.

Seating and safety restraints

9. Pull on the safety belt tongues to ensure they are both securely latched. If they are not latched, repeat Steps 7 and 8.

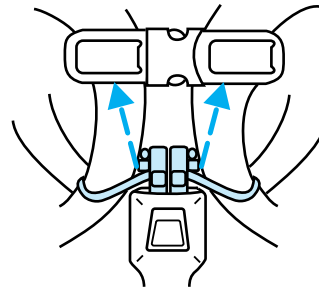

If necessary, the shoulder belts can be put in automatic locking mode (ALR) to limit the child's movement in the child seat. The ALR mode may be used if the child is sleeping or attempting to get out of the child seat.

If not placed in the ALR mode, the child seat shoulder belts are in a vehicle sensitive (emergency locking) mode, adjusting shoulder belt tightness in response to vehicle movement.

Activating the automatic locking mode (ALR) on the built-in child seat.

1. Pull out right shoulder belt fully.
2. Allow the belts to tighten snugly against child's shoulders.

Canceling the automatic locking mode (ALR) on the built-in child seat

1. Disconnect the chest clip and remove the left and right safety belt tongues from the crotch buckle.

Seating and safety restraints

2. Allow the shoulder belts to fully retract.

Removing your child from the built-in child seat

1. Disconnect the chest clip by squeezing the release tabs together and pulling the two sides apart.
2. Press the release button on the crotch buckle.

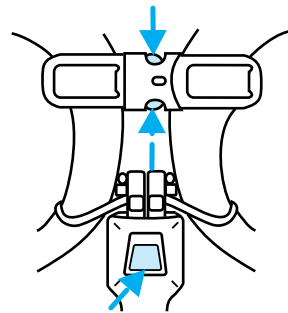

3. Slide the shoulder belts off the child's shoulders and remove child.

If ALR is engaged, hold either left or right shoulder belt fully out while helping the child slide his arms out of the belts.

4. Fold the cushion protector flap onto the child seat cushion. Slide the belt tongues up and out of the way of the cushion, then return the child seat cushion to the stowed (upright) position.

5. Slide the Velcro® straps through the D-rings on the child seat cushion and attach.

6. Slide head restraint down until the top of the head restraint is flush with the top of the adult seat back.

Seating and safety restraints

7. Press firmly on the top center of the built-in child seat head restraint to ensure it is stowed properly.

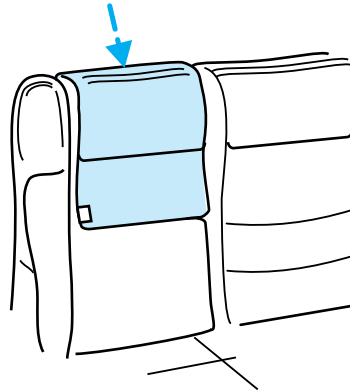

Inspecting the built-in child seat after a collision





All built-in child restraints, including seats, buckles, retractors, seat latches, interlocks, and attaching hardware should be inspected by a qualified dealer technician after any collision. If the child seat was in use during a collision, Ford recommends replacing it. However, if the collision was minor and a qualified technician finds that the child restraints do not show damage and continue to operate properly, they do not need to be replaced. Built-in child seats not in use during a collision should also be inspected and replaced if either damage or improper operation is noted.

Starting your vehicle

IMPORTANT SAFETY PRECAUTIONS

 Extended idling at high engine speeds can produce very high temperatures in the engine and exhaust system, creating the risk of fire or other damage.

 Do not park, idle, or drive your vehicle in dry grass or other dry ground cover. The emission system heats up the engine compartment and exhaust system, which can start a fire.

 Do not start your vehicle in a closed garage or other enclosed area. Never sit in a stopped vehicle for more than a short period of time with the engine running. Exhaust fumes are toxic. See *Guarding against exhaust fumes* later in this chapter for more instructions.

PREPARING TO START YOUR VEHICLE

Before starting the vehicle:

1. Make sure all vehicle occupants have buckled their safety belts. Refer to the *Seating and safety restraints* chapter for more information.

Starting your vehicle

2. Make sure the headlamps and vehicle accessories are off.

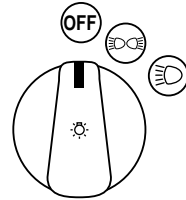

3. Make sure the parking brake is set and the gearshift lever is in P (Park).

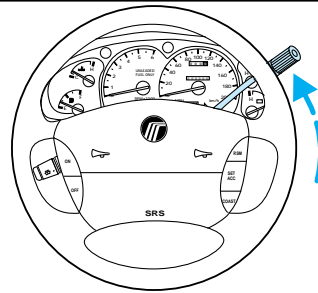
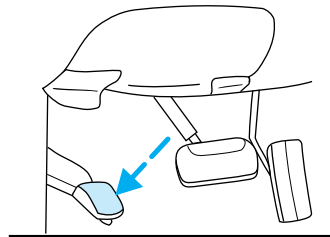

4. Turn the key to the ON position (without turning the key to START).

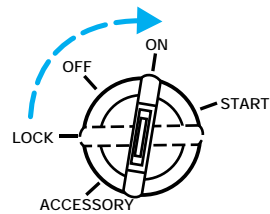

Starting your vehicle

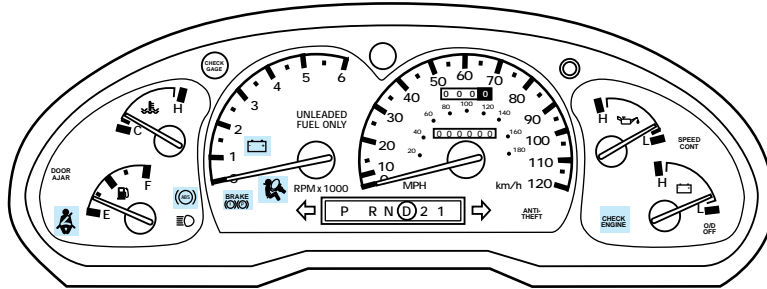

The above lights illuminate briefly.
If a light fails to illuminate, have
the vehicle serviced.

If the driver's safety belt is
fastened, the  light does not
illuminate.

STARTING THE VEHICLE

After completing the steps under
Preparing to start the vehicle:

1. Turn the key to START, hold
until engine is running, then
release. DO NOT press the
accelerator.

The key will return to the ON
position.

2. After idling for a few seconds,
apply the brake and release the
parking brake.

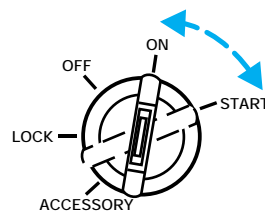

Special conditions when starting

Starting a cold engine

At temperatures -12°C (10°F) and
below, do not hold the key in the
START position longer than 15

Starting your vehicle

seconds. If the engine does not start on the first attempt:

1. Turn the ignition key to LOCK and wait approximately 10 seconds.
2. Try starting the engine again.

At temperatures above -12°C (10°F), do not hold the key in the START position longer than five seconds. If the engine does not start on the first attempt:

1. Turn the ignition key to LOCK and wait approximately five seconds.
2. Try starting the engine again.

Starting a warm engine

Do not hold the key in the START position for longer than five seconds. If the engine does not start on the first attempt:

1. Turn the ignition key to LOCK and wait a few seconds until the starter stops.
2. Try starting the engine again.

Starting the engine after two failed attempts (warm or cold)

If the engine does not start after two attempts:

1. Turn the key to LOCK and wait about two minutes.

Starting your vehicle

2. Press the accelerator all the way to the floor and hold.

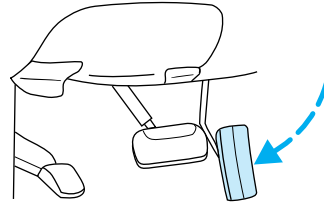

3. Turn the key to START. Release it once the engine starts.

4. Release the accelerator gradually as the engine speeds up.

If the engine still does not start, refer to *Fuel pump shutoff switch* in the *Roadside emergencies* chapter.

Engine block heater (if equipped)



To prevent electrical shock, do not use your engine block heater with ungrounded electrical systems or two-pronged (cheater) adapters.

Engine block heaters are strongly recommended if you live in a region where temperatures reach -23°C (-10°F) or below. An engine block heater works by warming the engine coolant. This improves engine starting by warming the engine faster. Engine block heater operation also allows the heater and defrost system to respond more quickly than usual.

Starting your vehicle

GUARDING AGAINST EXHAUST FUMES

Carbon monoxide, although colorless and odorless, is present in exhaust fumes. Take precautions to avoid its dangerous effects.



If you smell exhaust fumes inside your vehicle, have your dealer inspect your vehicle immediately. Do not drive if you smell exhaust fumes.

Have the exhaust and body ventilation system checked whenever:

- The vehicle is raised for service.
- The sound of the exhaust system changes.
- The vehicle has been damaged in a collision.

Starting your vehicle

Ventilating your vehicle

- If the engine is idling while the vehicle is stopped in an open area for long periods of time, open the windows at least 2.5 cm (1 inch). Adjust the heating or air conditioning to bring in fresh air.
- Improve vehicle ventilation by keeping all air inlet vents clear of snow, leaves and other debris.

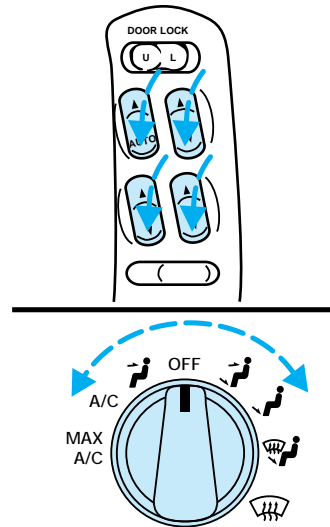

Driving

BRAKES

The anti-lock brake system (ABS)

Anti-lock brake operation differs slightly from standard brake operation.

Apply the brakes steadily. DO NOT pump the brakes in a panic stop. The brake system will prevent wheel lockup by automatically releasing and reapplying the brakes.

Even with ABS, the brakes could lock up on roads with alternating slippery and dry patches or with loose surfaces such as snow or gravel. Be careful when braking.

The ABS conducts a self-test each time the vehicle is driven. A mechanical noise may be heard while the system conducts its self-test.

Occasional brake squeal during light to moderate stops is normal. Significantly increased squeal is an indicator that brake service is needed.

After driving through standing water, gently apply the brakes several times to dry them.

If driving down a long or steep hill, shift to a lower gear and do not apply the brakes continuously. Continuously applying the brakes on a hill could overheat them and make them less effective.

ABS warning light

The  light in the instrument cluster illuminates and remains illuminated if an ABS fault is detected. Have your vehicle serviced as soon as possible.

Normal braking operation is still effective unless the  light is also illuminated.

Parking brake

The parking brake should be used whenever the vehicle is parked.

Push pedal downward to set the parking brake.

The  light in the instrument cluster illuminates and remains illuminated (when the ignition is turned to ON) until the parking brake is released.



Always set the parking brake fully and make sure that the gearshift is securely latched in P (Park).

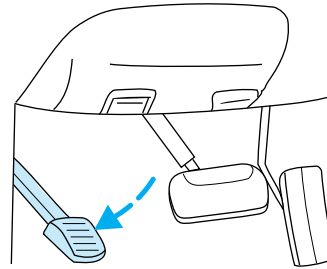



The parking brake is not designed to stop a moving vehicle. However, if the normal brakes fail, the parking brake can be used to stop your vehicle in an emergency. Since the parking brake applies only the rear brakes, the vehicle's stopping distance will increase greatly and the handling of your vehicle will be adversely affected.

Driving

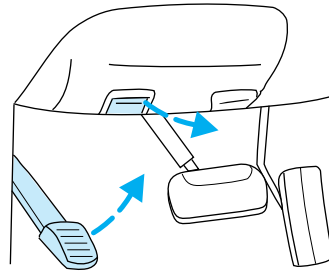
Pull release handle towards you to release parking brake.



 If the parking brake is fully released, but the  warning light remains on, have the brakes checked immediately. They may not be working properly.

AUTOMATIC TRANSMISSION OPERATION (4R70W)

 Hold the brake pedal down while you move the gearshift from position to position. If you do not hold the brake pedal down, your vehicle may move unexpectedly and injure someone.

Driving

Pull gearshift lever towards you and downward to move the automatic gearshift.

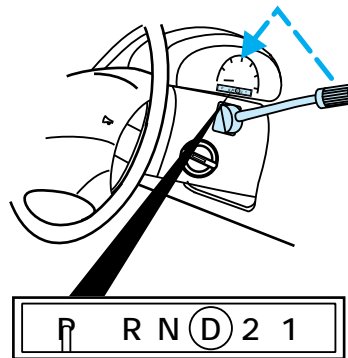

P - Park Always come to a complete stop before shifting into or out of P (Park).

 Always set the parking brake fully and make sure that the gearshift is securely latched in P (Park).

R - Reverse Always come to a complete stop before shifting into or out of R (Reverse).

N - Neutral Vehicle is free to roll.

 Do not leave the vehicle unattended with the transfer case in the N (Neutral) position. Always set the parking brake fully and turn off the ignition when leaving the vehicle.

Driving

Ⓢ - **Overdrive** The normal driving position for the best fuel economy. Transmission operates in gears 1-4. Ⓢ (Overdrive) can be disengaged by pressing the transmission control switch on the gearshift lever. The transmission control indicator light on instrument cluster will remain off.

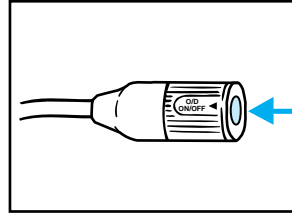
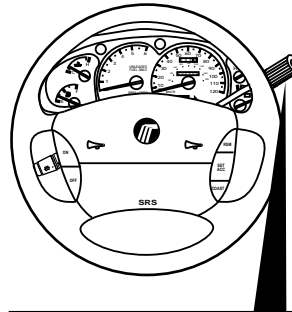

D - Drive Not shown on the display. Activate by pressing transmission control switch. $\frac{O/D}{OFF}$ will illuminate on the instrument cluster. Transmission operates in gears 1-3. Provides more engine braking than Ⓢ (Overdrive) and is useful when towing a trailer or heavy loads through hilly areas.

To return to normal overdrive mode, press the transmission control switch again. $\frac{O/D}{OFF}$ will turn off.

When starting your vehicle, the transmission will automatically return to normal Ⓢ (Overdrive) mode.

2 - Second Use 2 (Second) to start-up on slippery roads or to provide additional engine braking

on downgrades. Transmission operates in gears 1-2.

1 - Low Use 1 (Low) to provide maximum engine braking on steep downgrades. Upshifts can be made by shifting to 2 (Second) or to **Ⓢ** (Overdrive). Selecting 1 (Low) at higher speeds causes a shift to 2 (Second), and will shift to 1 (Low) after vehicle decelerates to the proper speed.

Brake-shift interlock

This vehicle is equipped with a brake-shift interlock feature that prevents the gearshift from being moved from P unless the brake pedal is depressed.

If you cannot move the gearshift out of P with the brake pedal depressed:

1. Apply the parking brake.
2. Turn ignition key to LOCK, then remove the key.
3. Insert the key and turn to OFF.
4. Apply brake pedal and shift to N (Neutral).
5. Start the vehicle.

If it is necessary to use the above procedure to move the gearshift, it is possible that a fuse has blown and the vehicle's brakelamps may not be operating properly. Refer to *Fuses and relays* in the *Roadside emergencies* chapter.

Driving



Do not drive your vehicle until you verify that the brakelamps are working.

If your vehicle gets stuck in the mud or snow it may be rocked out of the spot. To rock the vehicle out, shift between forward and reverse gears in a steady rhythm. Press lightly on the accelerator in each gear. Do not rock the vehicle for more than a few minutes, because it could damage the vehicle.



Do not spin the wheels at over 55 km/h (35 mph). The tires may fail and injure a passenger or bystander.

ALL-WHEEL DRIVE (AWD) SYSTEM (IF EQUIPPED)

Your vehicle is equipped with a full-time All-Wheel Drive (AWD) transfer case. Power is constantly supplied to all four wheels through a transfer case. The AWD system is full-time and has no external controls.

The AWD transfer case utilizes a viscous clutch that distributes torque to the front and rear differentials (approximately 35% front and 65% rear). The viscous clutch is filled with a high viscosity fluid; see *Lubricant specifications* for more information.

All utility-type and AWD vehicles have special design and equipment

features to make them capable of performing in a wide variety of off-road applications. Specific design characteristics give them higher centers of gravity than ordinary passenger cars.



Utility and four-wheel drive vehicles are NOT designed for cornering at speeds as high as passenger cars any more than low-slung sports cars are designed to perform satisfactorily under off-road conditions. Avoid sharp turns or abrupt maneuvers in these vehicles.

DRIVING OFF ROAD WITH ALL-WHEEL DRIVE (AWD)

Your vehicle is specially equipped for driving on sand, snow, mud, and rough terrain and has operating characteristics that are somewhat different from conventional vehicles, both on and off road. The following information will help you learn to properly use AWD.

When using AWD, maintain steering wheel control at all times, especially in rough terrain. Since sudden changes in terrain can result in abrupt steering wheel motion, make sure you grip the steering wheel from the outside. Do not grip the spokes.

Drive cautiously to avoid vehicle damage from concealed objects such as rocks and stumps. You

Driving

should either know the terrain or examine maps of the area before driving. Map out your route before driving in the area. For more information on driving off-road, read *Four-Wheeling* in your owner's portfolio.

Sand

When driving over sand, try to keep all four wheels on the most solid area of the trail. Do not reduce the tire pressures but shift to a lower gear and drive steadily through the terrain. Apply the accelerator slowly and avoid spinning the wheels.

Mud and water

If you must drive through high water, drive slowly. Traction or brake capability may be limited.

When driving through water, determine the depth; avoid water higher than the bottom of the hubs (if possible) and proceed slowly. If the ignition system gets wet, the vehicle may stall.

Once through water, always try the brakes. Wet brakes do not stop the vehicle as effectively as dry brakes. Drying can be improved by moving your vehicle slowly while applying light pressure on the brake pedal.

After driving through mud, clean off residue stuck to rotating driveshafts and tires. Excess mud stuck on tires and rotating driveshafts causes an imbalance

that could damage drive components.

If the transmission and transfer case are submerged in water, their fluids should be checked and changed, if necessary.

All rear axle lubricants must be replaced every 160,000 km (100,000 miles) or if the axle has been submerged in water. Otherwise, check the lubrication of the rear axle according to the intervals in the *Service Guide*.

Driving on hill or slope terrain

When driving on a hill, avoid driving crosswise or turning on steep slopes. You could lose traction and slip sideways. Drive straight up, straight down or avoid the hill completely. Know the conditions on the other side of a hill before driving over the crest.

When climbing a steep hill, start in a lower gear rather than downshifting to a lower gear from a higher gear once the ascent has started. This reduces strain on the engine and the possibility of stalling.

When descending a steep hill avoid sudden braking. Rapid pumping of the brake pedal will help slow the vehicle and still maintain steering control.

When speed control is on and you are driving uphill, your vehicle speed may drop considerably, especially if you are carrying a

Driving

heavy load. If vehicle speed drops more than 15 - 25 km/h (8 - 14 mph) the speed control will cancel automatically. Resume speed with accelerator pedal.

If speed control cancels after climbing the hill, reset speed by pressing and holding the SET ACCEL button or returning to previous speed by pressing the RESUME button (to resume speeds over 50 km/h [30 mph]).

Automatic transmissions may shift frequently while driving up on steep grades. Eliminate frequent shifting by shifting out of  (Overdrive) into D (Drive).

Driving on snow and ice

An AWD vehicle has advantages over two-wheel drive vehicles in snow and ice but can skid like any other vehicle.

Avoid sudden applications of power and quick changes of direction on snow and ice. Apply the accelerator slowly and steadily when starting from a full stop.

When braking, apply the brakes as you normally would. In order to allow the anti-lock brake system (ABS) to operate properly, keep steady pressure on the brake pedal.

Allow more stopping distance and drive slower than usual. Consider using one of the lower gears.

If the vehicle is stuck, shift the transmission in a steady motion

between forward and reverse gears. DO NOT rock the vehicle for more than a few minutes. The transmission and tires may be damaged or the engine can overheat.



Do not spin the wheels at over 55 km/h (35 mph). The tires may fail and injure a passenger or bystander.

VEHICLE LOADING



It is extremely dangerous to ride in a cargo area, inside or outside of a vehicle. In a collision, people riding in these areas are more likely to be seriously injured or killed.



Do not allow people to ride in any area of your vehicle that is not equipped with seats and safety belts.



Be sure everyone in your vehicle is in a seat and using a safety belt properly.

Before loading a vehicle, familiarize yourself with the following terms:

- **Base Curb Weight:** Weight of the vehicle including any standard equipment, fluids, lubricants, etc. It does not include passengers or aftermarket equipment.

Driving

- **Payload:** Combined maximum allowable weight of cargo, passengers and optional equipment. The payload equals gross vehicle weight rating (GVWR) minus base curb weight.
- **GVW (Gross Vehicle Weight):** Base curb weight plus the payload weight (including passengers, cargo, and optional equipment). Remember, the GVW is not a limit or a specification.
- **GVWR (Gross Vehicle Weight Rating):** Maximum total weight of the base vehicle, passengers, optional equipment and cargo. The GVWR is specific to each particular vehicle and is listed on the Safety Compliance Certification Label on the driver's door pillar.
- **GAWR (Gross Axle Weight Rating):** Carrying capacity for each axle system (front and rear). This amount is specific to each particular vehicle and is listed on the Safety Compliance Certification Label on the driver's door pillar.
- **GCWR (Gross Combined Weight Rating):** Maximum combined weight of the towing vehicle (including passengers and cargo) and the trailer. The GCWR indicates the maximum loaded weight that the vehicle is allowed to tow.

- **Maximum Trailer Weight Rating:** Maximum weight of a trailer the vehicle is permitted to tow. The maximum trailer weight rating equals the vehicle curb weight for each engine/transmission combination, any required option weight for trailer towing and the weight of the driver from the GCWR for the towing vehicle.
- **Maximum Trailer Weight:** Maximum weight of a trailer the loaded vehicle (including passengers and cargo) is permitted to tow. It is determined by subtracting the weight of the loaded towing vehicle from the GCWR for the towing vehicle.
- **Trailer Weight Range:** Specified weight range that the trailer must fall within that ranges from zero to the maximum trailer weight rating.

Remember to figure in the tongue load of your loaded trailer when figuring the total weight.



If the GVWR or the GAWR specified on the Safety Compliance Certification Label is exceeded, your vehicle may be damaged or you may lose control and injure someone.

To obtain correct weights, try taking your vehicle to a shipping company or an inspection station for trucks.

Driving

Do not use replacement tires with lower weight capacities than the original because they may lower the vehicle's GVWR and GAWR limitations. Replacement tires with a higher weight limit than the originals do not increase the GVWR and GAWR limitations.

TRAILER TOWING

Your vehicle may tow a Class I or II trailer provided the maximum trailer weight is less than or equal to the maximum trailer weight listed for your engine and rear axle ratio. See the *Trailer towing table* later in this chapter.

Do not exceed the maximum loads stated on the Safety Compliance Certification Label. Refer to *Vehicle loading* for a definition of the terms on the label.

Your vehicle's load capacity is designated by weight, not by volume, so you cannot necessarily use all available space when loading a vehicle.

Distribute the trailer load so that only 10 to 15% of the total weight of the trailer is on the tongue. Tie down the load so that it does not shift and change the weight on the hitch.

Towing a trailer places an additional load on your vehicle's engine, transmission, axle, brakes, tires and suspension. Inspect these components carefully before and after any towing operation.

 If the GVWR or the GAWR specified on the Safety Compliance Certification Label is exceeded, your vehicle may be damaged or you may lose control and injure someone.

 Towing trailers beyond the maximum recommended gross trailer weight exceeds the limits of the vehicle and could result in engine damage, transmission/axle damage, structural damage, loss of control, and personal injury.

Calculating the load your vehicle can carry/tow

1. Use the Safety Compliance Certification Label to find the axle code number and engine type for your vehicle.
2. Use the appropriate maximum Gross Combined Weight Rating (GCWR) chart to find the maximum GCWR for your type engine and rear axle ratio.
3. Weigh your vehicle as you customarily operate the vehicle without cargo. To obtain correct weights, try taking your vehicle to a shipping company or an inspection station for trucks.
4. Subtract your loaded vehicle weight from the maximum GCWR on the following charts. This is the maximum trailer weight your vehicle can tow and must fall

Driving

below the maximum shown under maximum trailer weight on the chart.

Trailer Towing Table 4R70W Automatic Transmission				
Engine	Rear Axle Ratio	Maximum GCWR kg (lb) ¹	Maximum Trailer Weight kg (lb) ²	Maximum Frontal Area of Trailer ft
2-Wheel Drive				
5.0L	3.73	4,990 (11,000)	3,039 (6,700)	50
All-Wheel Drive				
5.0L	3.73	4,990 (11,000)	2,944 (6,500)	50

¹For high altitude operation, reduce GCWR by 2% per 300 meters (1,000 ft) elevation.

²To determine the maximum trailer weight designed for your particular vehicle as equipped, follow the section *Calculating the load your vehicle can carry/tow* earlier in this section.

Preparing to tow

Use the proper equipment for towing a trailer, and make sure it is properly attached to your vehicle. See your dealer or a reliable trailer dealer if you require assistance.

Hitches

Do not use or install hitches that clamp onto the bumper or to the axle. Underbody hitches are acceptable if installed properly.

The rear bumper has an integral hitch and only requires a ball with a 3/4 inch shank diameter. The

bumper has a Class II rating (1590 kg/3500 lb trailer weight and 159 kg/350 lb tongue weight).

Safety chains

Always connect the trailer's safety chains to the vehicle. To connect chains when towing with the step bumper, cross the chains under the trailer tongue and allow slack for turning corners. Connect the chains to the holes in the underside of the hitch plate for a Class II frame mounted hitch.

When using a frame mounted trailer hitch, attach the safety chains to the frame mounted hitch using the recommendations supplied by the hitch manufacturer.

Trailer brakes

Trailer brakes are required on most towed vehicles weighing over 680 kg/ 1500 lb. Use electric brakes or manual, automatic, or surge-type hydraulic brakes that meet Federal and local regulations. Install and adjust the brakes according to the manufacturer's instructions.



Do not connect a trailer's hydraulic brake system directly to your vehicle's brake system. Your vehicle may not have enough braking power and your chances of having a collision greatly increase.

Driving

Trailer lamps

Trailer lamps are required on most towed vehicles. Make sure your trailer lamps conform to Federal and local regulations. See your dealer or trailer rental agency for the proper instructions and equipment for hooking up trailer lamps.



Do not hook the trailer lamps directly into the vehicle's lighting system wiring. If the trailer lamps are not installed properly, the warning lights in the instrument cluster may not work properly.

Driving while you tow

Do not drive faster than 88km/h (55 mph) while towing a trailer. Do not drive faster than 72 km/h (45 mph) while towing in hilly country or on hot days.

Speed control may shut off if you are towing on very long, steep grades.

When towing a trailer:

- Use D (3rd gear) rather than Ⓧ (Overdrive) while towing up or down steep hills. This will eliminate excessive downshifting and upshifting for optimum fuel economy and transmission cooling.
- Anticipate stops and brake gradually.

Servicing while towing

If you tow a trailer for long distances, your vehicle will require more frequent service intervals. Refer to the *Service Guide* for more information.

Trailer towing

- Practice turning, stopping and backing in an area before starting on a trip to get the feel of the vehicle/trailer combination. When turning, drive slightly beyond the normal turning point so the trailer wheels will clear curbs and other obstacles.
- Allow more room for stopping with a trailer attached.
- The trailer tongue weight should be 10-15% of the loaded trailer weight for a Class I or II rear bumper hitch.
- After you have travelled about 80 km (50 miles), thoroughly check your hitch, electrical connections and trailer wheel lug nuts.
- When stopped in traffic for long periods of time in hot weather, place the gearshift in P (Park) to increase idle speed. This aids engine cooling and air conditioner efficiency.
- Vehicles with trailers should not be parked on a grade. If you must park on a grade, place wheel chocks under the trailer's wheels.

Driving

Luggage rack (if equipped)

Load luggage as far back as it will safely go without loading more than 45 kg (100 lb) or cause the vehicle to exceed the Gross Vehicle Weight Rating (GVWR) or its Gross Axle Weight Rating (GAWR). Use the following steps to adjust the luggage rack.

- Turn adjustment wheel backward to unlock crossbar and slide crossbar forward or backward.
- Turn adjustment wheel forward to lock crossbar.

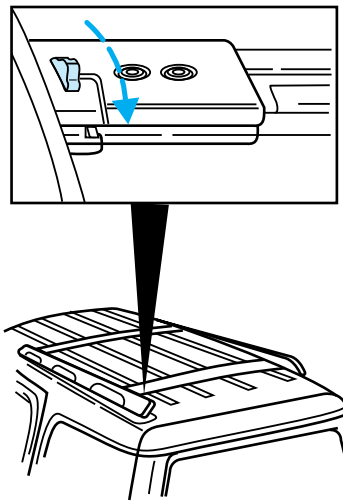

FUEL CONSUMPTION

Fuel economy can be improved by avoiding:

- lack of regular, scheduled maintenance
- excessive speed
- rapid acceleration
- driving with the brake pedal depressed

Driving

- sudden stops
- extended engine idling
- use of speed control in hilly terrain
- extended use of the air conditioner, defroster, rear window defroster and other accessories
- underinflated tires
- heavy loads
- aftermarket add-ons such as bike, ski or luggage racks, bug deflectors, etc.

Roadside emergencies

HAZARD SWITCH

Use the hazard flashers to warn traffic of vehicle problems.

Press button down to activate hazard flashers.

Press button again to deactivate hazard flashers.

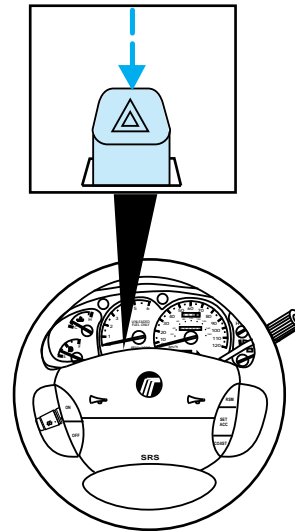

FUEL PUMP SHUTOFF SWITCH

The fuel pump shutoff switch stops the fuel pump when the vehicle has been involved in a collision or major jolt. If the vehicle does not start, it is possible that the fuel pump shutoff switch needs to be reset.



If you see or smell fuel, do not reset the switch or try to start your vehicle. Have all the passengers get out of the vehicle and call the local fire department or a towing service.

Roadside emergencies

Press the red button to reset the fuel pump.

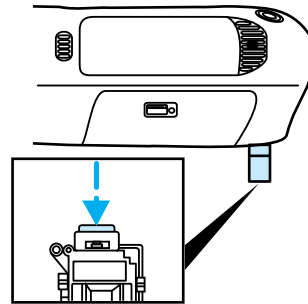

FUSES AND RELAYS

Fuses

If electrical components in the vehicle are not working, a fuse may have blown. Blown fuses are identified by a broken wire. Check the appropriate fuses before replacing any electrical components.

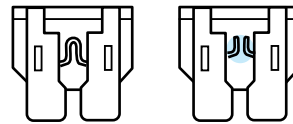

 Always replace a fuse with one that has the specified amperage rating. Using a fuse with a higher amperage rating can cause severe wire damage and could start a fire.

Roadside emergencies

Standard fuse amperage rating and color

Fuse Rating	Color
7.5 amp	Brown
10 amp	Red
15 amp	Blue
20 amp	Yellow
30 amp	Light Green
30 amp fuse link	Pink
40 amp	Green
60 amp fuse link	Yellow
80 amp fuse link	Black
100 amp fuse link	Blue

Even after a fuse is replaced, it will continue to blow if the cause of the overload is not identified and corrected. If a fuse continues to blow, have the vehicle's electrical system checked.

Passenger compartment fuse panel

Pull panel outward to access passenger compartment fuse panel.

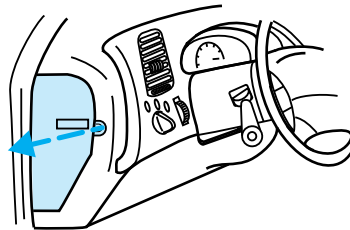

Roadside emergencies

Use the fuse puller tool provided on the passenger compartment fuse panel cover to replace fuses.

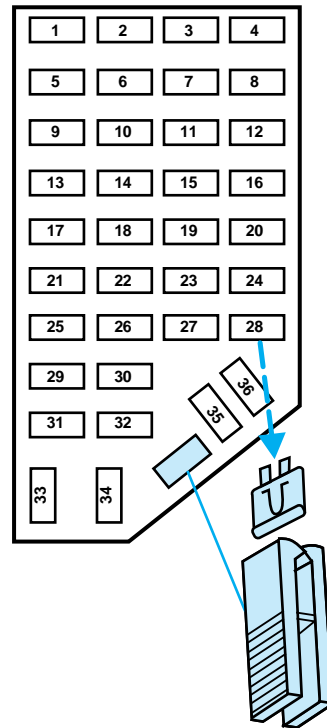

Number	Fuse Amperage Rating	Circuits Protected
1	7.5 amp	Power mirror, power antenna
2	7.5 amp	High-mount brakelamp
3	15 amp	Parking lamps
4	10 amp	Left headlamp
5	10 amp	Data link connector
6	7.5 amp	Air bag system, blower relay

Roadside emergencies

Number	Fuse Amperage Rating	Circuits Protected
7	7.5 amp	Illumination switches
8	10 amp	Right headlamp, fog lamp system
9	10 amp	Autolamps
10	7.5 amp	Rear blower, speed control, GEM system, brake interlock, overhead console
11	7.5 amp	Warning lamps
12	10 amp	Liftgate wiper/washer, front washer
13	15 amp	Brake on/off switch
14	10 amp	Anti-lock system
15	7.5 amp	Air bag system, instrument cluster
16	30 amp	Wiper run relay
17	15 amp	Cigar lighter
18	15 amp	A/C system
19	25 amp	Ignition coil, PCM system
20	7.5 amp	Radio, power antenna, GEM system, anti-theft
21	15 amp	Turn/hazard flasher
22	10 amp	Turn signals
23	10 amp	Rear wiper system
24	10 amp	Anti-theft relay
25	7.5 amp	Instrument cluster, GEM system

Roadside emergencies

Number	Fuse Amperage Rating	Circuits Protected
26	10 amp	4R70W overdrive, DRL system, backup lamps, rear defroster relay
27	10 amp	Underhood lamp, map lights, glove box lamp, overhead lamp, visor lamps, accessory delay, dimmer switch illumination
28	7.5 amp	GEM system
29	10 amp	Audio system
30	-	Not used
31	7.5 amp	Rear blower motor relay
32	7.5 amp	Heated rear window
33	15 amp	DRL module, RH and LH headlamp, instrument cluster
34	7.5 amp	Luxury audio system
35	-	Not used
36	-	Not used

Roadside emergencies

Power distribution box

Lift cover towards front of vehicle to access the power distribution box.

The high-current fuses in the power distribution box protect your vehicle's main electrical systems from overloads. The high current fuses are coded as follows:

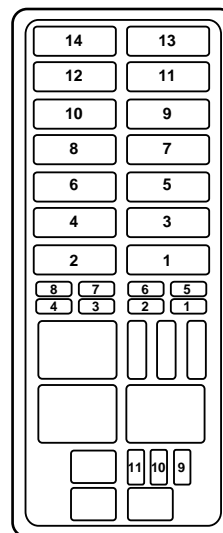
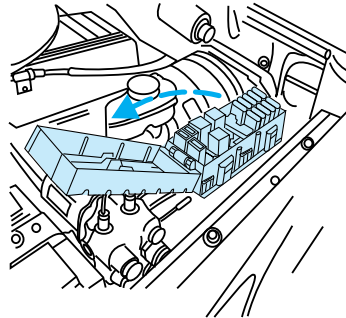

Roadside emergencies

High Current Fuse Rating	Color
20 amp	Yellow
30 amp	Light green
40 amp	Orange
50 amp	Red
60 amp	Blue

 Always disconnect the battery before servicing high current fuses.

 Always replace the cover to the power distribution box before reconnecting the battery or refilling fluid reservoirs.

Maxi fuses		
Fuse	Amps	Circuits protected
1	30 amp	Rear window defrost relay
2	30 amp	PCM power relay
3	20 amp	Fuel pump relay, RAP module
4	20 amp	Headlamps, autolamps, multi-function switch
5	30 amp	4WABS pump relay
6	30 amp	4WABS main relay
7	20 amp	Trailer tow relays

Roadside emergencies

Maxi fuses		
Fuse	Amps	Circuits protected
8	30 amp	Battery saver relay, headlamp relay
9	50 amp	Blower motor relay, blower motor
10	30 amp	Power seats, power lumbar, door lock/unlock relays, accessory delay relay
11	20 amp	Horn relay, Powertrain control module (PCM)
12	-	Not used
13	60 amp	Hazard flasher, brake ON/OFF switch, cigar lighter, power antenna, power mirrors, autolamps, instrument cluster, GEM, radio, blower motor relay
14	60 amp	Ignition switch
Mini fuses		
Fuse	Amps	Circuits protected
1	30 amp	Premium sound
2	15 amp	Liftgate wiper relays
3	30 amp	Auxiliary power
4	10 amp	Air bag diagnostic monitor
5	-	Not used

Roadside emergencies

Mini fuses		
Fuse	Amps	Circuits protected
6	15 amp	Generator/voltage regulator
7	20 amp	Not used
8	15 amp	Foglamp relay, daytime running lamp module
9	-	Not used
10	-	Not used
11	20 amp	HEGO system

Relays

Relays are located in the power distribution box.

Relays receive signals from components or systems and transfer these signals to activate or deactivate other components or systems.

Mercury recommends that relays be replaced by a qualified technician.

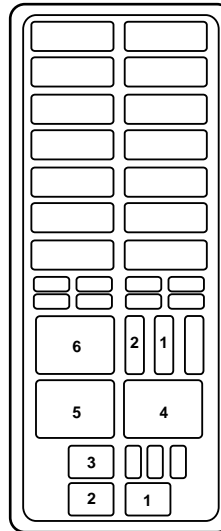

Roadside emergencies

Relay number	Circuits connected
1	Wiper run relay
2	Horn relay
3	Wiper HI/LO relay
4	WOT A/C relay
5	PCM power relay
6	Fuel pump relay
Diode number	Circuits connected
1	ABS diode
2	PCM diode

CHANGING TIRES

Tire change procedure

1. Park on a level surface.
2. Activate the hazard flashers.
3. Set the parking brake.
4. Place the gearshift in P (Park).
5. Block the diagonally opposite wheel.
6. Remove the jack and lug wrench.

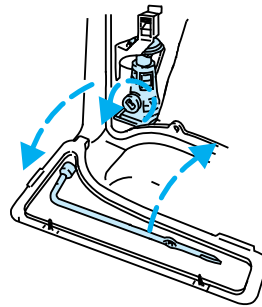

Roadside emergencies

7. Remove the jack handle (located underneath rear seat).

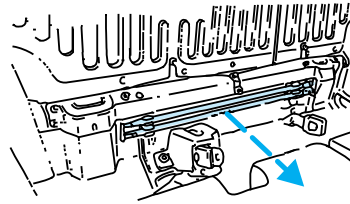

8. Assemble the jack handle to the lug wrench.

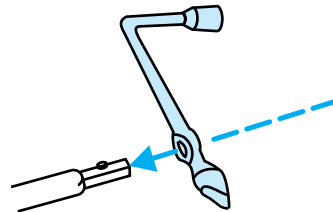

9. Insert drive section of the jack handle into the actuator hole and turn counterclockwise until the cable is slack enough to allow spare tire to be pulled rearward from under the vehicle.

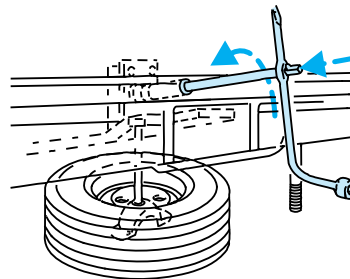

10. Slide spare tire rearward and remove retainer.

Roadside emergencies

11. Insert tapered end of the lug nut wrench behind hubcaps and twist off.

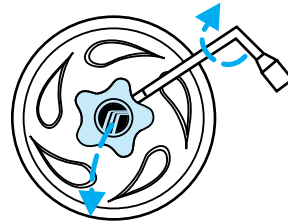

 Not using the tapered end of the lug nut wrench at the pry-off notches may result in damage to the finish of the wheel and ornament.

12. Loosen the wheel lug nuts with the lug wrench about one half turn.

13. Position the jack on the lower suspension arm to raise front wheel.

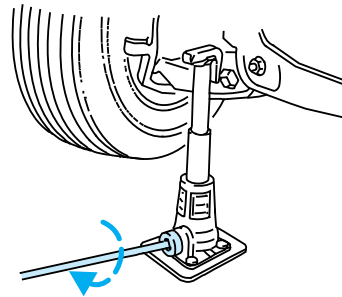

Roadside emergencies

Position the jack under the rear axle to raise the rear wheel.

14. Turn the jack handle clockwise and raise the vehicle until the tire just clears the ground.

15. Remove the wheel lug nuts and flat tire, and install the spare.

16. Install the lug nuts and tighten until snug.

 Use of wheel or lug nuts other than original equipment could cause damage to the wheel or mounting system and allow the wheels to come off while the vehicle is in motion.

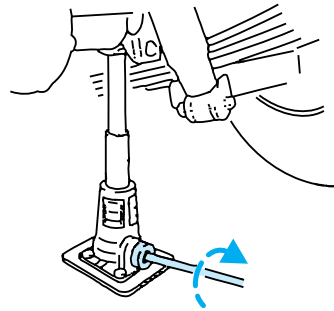

17. Lower the vehicle and tighten the wheel lug nuts as shown.

18. Unblock the wheels and put the flat tire, jack, jack handle and lug wrench away.

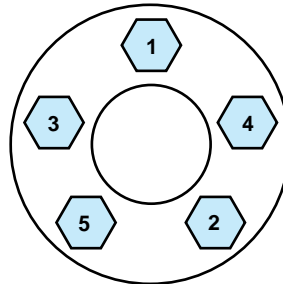

Stowing flat tires

Stow aluminum wheel and tire with valve stem down.

Roadside emergencies

To stow largest flat tire, place inside vehicle and secure with webbing retainer.

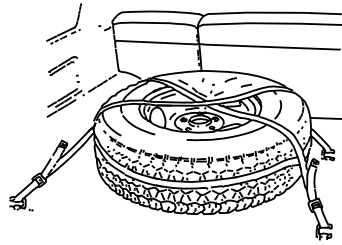

JUMP STARTING A DISABLED VEHICLE

 The gases around the battery can explode if exposed to flames, sparks, or lit cigarettes. An explosion could result in injury or vehicle damage.

 To protect yourself when charging a battery, always shield your face and eyes. Make sure that you can breath fresh air.

 Batteries contain sulfuric acid which burns skin, eyes and clothing.

If the acid touches someone's skin, eyes, or clothing, immediately flush the area with water for at least 15 minutes. If someone swallows the acid, have him or her drink lots of milk or water first, then Milk of Magnesia, a beaten egg, or

Roadside emergencies

vegetable oil. Call a doctor immediately.

 To avoid damage or injury, follow these directions in the order they are given. If in doubt, call for road service.

Before jump starting a vehicle:

- Make sure the booster battery vehicle has a 12-volt starting system (a 24-volt power supply will cause vehicle damage).
- Park the vehicles close to each other, but do not allow the vehicles to touch each other.
- Check to make sure neither battery is disconnected.
- Remove any excessive corrosion from the battery terminals.
- Turn on the heater fan in each vehicle to prevent damage from voltage surges.

To jump start the vehicle, connect the jumper cables in the following order:

1. Disabled battery positive terminal.
2. Booster battery positive terminal.
3. Booster battery negative terminal.
4. Disabled vehicle engine.

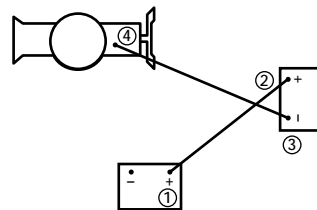

Roadside emergencies



Do not connect the end of the second cable to the negative (-) terminal of the battery to be jumped. A spark may cause an explosion of the gases that surround the battery.

5. Start the engine in the vehicle with the booster battery.
6. Wait a few minutes and start the engine in the vehicle with the disabled battery.
7. After a few minutes, the disabled battery should be recharged. Disconnect the jumper cables in reverse order.

Let the vehicle idle for a few minutes to allow the engine to relearn the proper idle conditions. Avoid using unnecessary electrical accessories for a short while to let the battery fully recharge. A battery charger may need to be used to fully recharge the battery.

Roadside emergencies

WRECKER TOWING

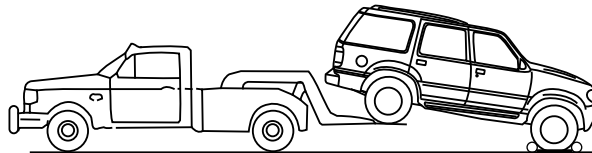
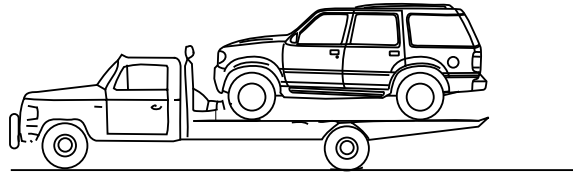
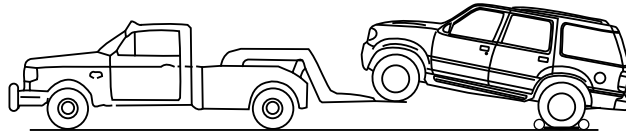

It is recommended that your vehicle be towed with wheel lift and dollies or flatbed equipment. Do not tow with slingbelt equipment. Ford Motor Company has not developed or approved a T-hook or slingbelt towing procedure.

Maintenance and care

SERVICE RECOMMENDATIONS

Whenever possible, Ford has designed parts that do not require servicing. However, when servicing is required, Ford's goal is to make servicing your vehicle as easy as possible. To help you:

- We highlight do-it-yourself items in the engine compartment for easy location.
- Often, parts (such as the headlamp bulbs) may be replaced without tools.
- We provide you with a *Service Guide* that makes tracking routine service of your vehicle easy.

If your vehicle requires professional servicing, your dealership can provide the necessary parts and service. Check the *Warranty Guide* to find out which parts and services are covered. Use only recommended fuels, lubricants, fluids, and service parts conforming to Ford specifications. Motorcraft parts are designed and built to provide the best performance in your vehicle.

Precautions for servicing your vehicle

Be particularly careful when inspecting or servicing your vehicle. Here are some general precautions for your safety:

- Do not work on a hot engine. The engine cooling fan may

Maintenance and care

come on unexpectedly; always turn the engine off and let it cool.

 The cooling fan is automatic and may come on at any time. Always disconnect the negative terminal of the battery before working near the fan.

- Never get under a vehicle supported only by a jack. If you must work under a vehicle, use safety stands.
- Keep all lit cigarettes and other smoking materials away from the battery and all fuel-related parts.

Working with the engine off

1. Set the parking brake and make sure that the gearshift is securely latched in P (Park).
2. Turn the engine off and remove the key from the ignition.
3. Block the wheels to prevent the vehicle from moving unexpectedly.

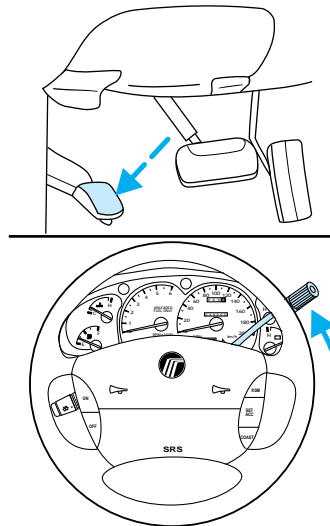

Maintenance and care

Working with the engine on

1. Set the parking brake and make sure that the gearshift is securely latched in P (Park).
2. Do not work on a vehicle in an enclosed space with the engine running.
3. Block the wheels to prevent the vehicle from moving unexpectedly.
4. If work must be done with the engine running, avoid wearing loose clothing or jewelry that could get caught in moving parts. Take appropriate precautions with long hair.

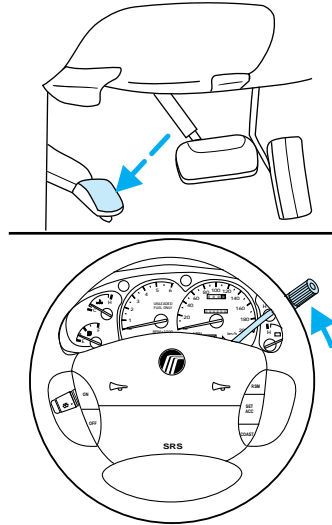

Opening the hood

1. Inside the vehicle, pull the hood release handle located under the steering column.
2. While applying downward pressure on the hood, push the hood latch handle located behind the grille near the center front of the vehicle to the left.
3. Lift the hood.

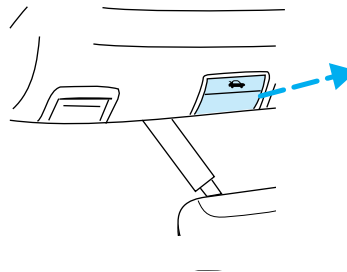

After closing the hood, try to lift it to be sure that it is closed securely.

Lubricate the hood latch every six months to ensure proper operation.

Maintenance and care

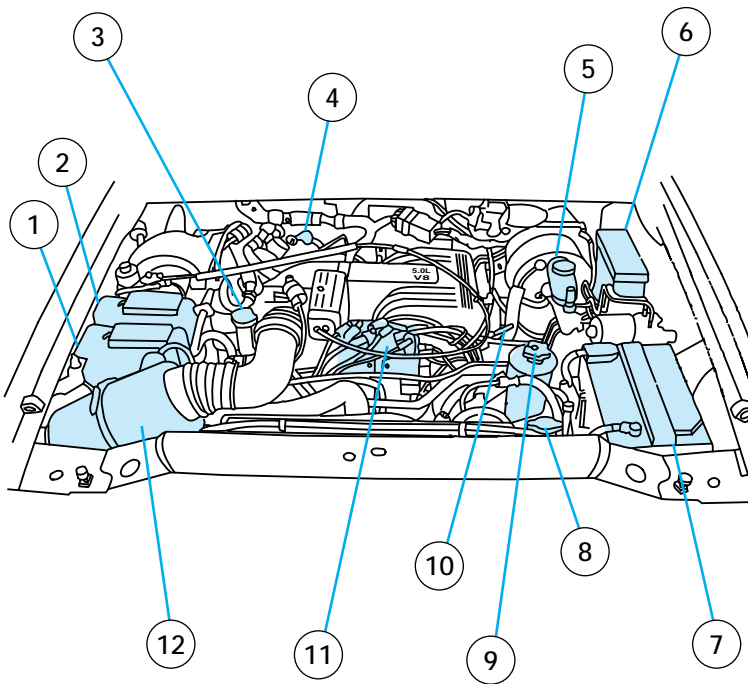

IDENTIFYING COMPONENTS IN THE ENGINE COMPARTMENT

- | | |
|-------------------------------------|----------------------------------|
| ① Engine coolant recovery reservoir | ⑦ Battery |
| ② Windshield washer reservoir | ⑧ Radiator cap |
| ③ Engine oil filler tube | ⑨ Power steering fluid reservoir |
| ④ Automatic transmission dipstick | ⑩ Engine oil dipstick |
| ⑤ Brake master cylinder | ⑪ Ignition coil packs |
| ⑥ Power distribution box | ⑫ Air cleaner |

Maintenance and care

CHECKING AND ADDING ENGINE OIL

Use WSS-M2C153-F motor oil CERTIFIED FOR GASOLINE ENGINES by the American Petroleum Institute.

Engine oils with an SAE 5W-30 viscosity and displaying the American Petroleum Institute certification mark are preferred for your vehicle. They provide the best engine performance, fuel economy and engine protection for all climates down to -25°C (-15°F).

Do not use:

- “non-detergent” oils
- oils labeled API SA, SB, SC, SD, SE, SF, or SG
- additional engine oil additives, oil treatments or engine treatments

Additional engine oil additives, oil treatments, or engine treatments are never needed and could, under certain conditions, lead to engine damage which is not covered by your Ford warranty.

Synthetic engine oils which are CERTIFIED and of the preferred viscosity may be used in your engine. The engine oil and oil filter must still be changed according to the *Service Guide*.

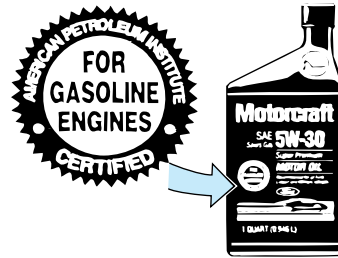

Maintenance and care

Checking the engine oil

Check the engine oil every time you fuel your vehicle.

Check the engine oil level more frequently if the vehicle is carrying a heavy load, towing a trailer, idling for extended periods (like police, taxi, or shuttle service vehicles), or driven at high speeds for extended periods of time.

To check engine oil:

1. Once the engine is warm, turn the engine off. Make sure the vehicle is parked on level ground.
2. Depress the parking brake. Place the gearshift in P (Park).
3. Open the hood. Protect yourself from engine heat.
4. Remove the engine oil dipstick and wipe clean. Reinsert the dipstick fully, then remove it again. The oil level should be between the MIN and MAX lines. If the oil level lies between the MIN and MAX lines, there is no need to add.
5. If the oil level is below the MIN line, add engine oil as necessary and recheck the oil level. If the oil level is above the letter "M" in "MAX," engine damage and/or high oil consumption may occur and some oil must be removed from the engine.

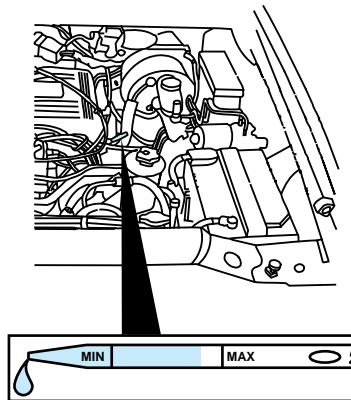

Maintenance and care

Adding engine oil

If the fluid level is below the MIN line, add engine oil. Add engine oil through the oil filler cap and use a funnel to pour oil into the opening.

Make sure you use a certified engine oil of the preferred viscosity.

Recheck the oil level. Make sure that the oil level is not above the MAX line on the dipstick.

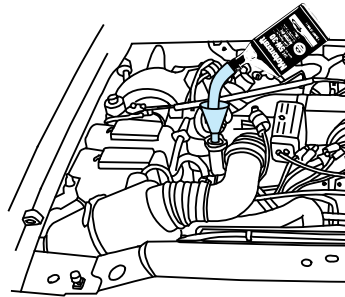

 Continuous contact with USED motor oil has caused cancer in laboratory rats.

Ford production and aftermarket (Motorcraft) oil filters are designed for added engine protection and long life. If a replacement oil filter is used that does not meet Ford material and design specifications, startup engine noises or knock may be experienced.

It is recommended you use the appropriate Motorcraft oil filter (or another brand meeting Ford specifications) for your engine application.

CHECKING AND ADDING BRAKE FLUID

Brake fluid should be checked and refilled as needed at least once each year.

Maintenance and care

1. Clean the reservoir cap before removal to prevent dirt or water from entering the reservoir.
 2. Visually inspect the fluid level.
 3. If necessary, add brake fluid until the level reaches within 1/8" of the MAX line on the reservoir.
- Do not exceed MAX.

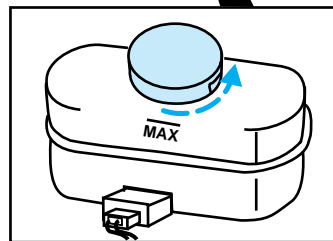
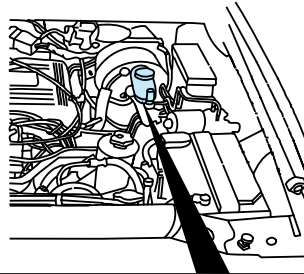

Use only a DOT 3 brake fluid certified to meet Ford specification ESA-M6C25-A. Refer to *Lubricant specifications*.



Brake fluid is toxic.



If you use brake fluid that is not DOT 3, you will cause permanent damage.



Do not let the reservoir in the master cylinder run dry. This may cause the brakes to fail.

Maintenance and care

CHECKING AND ADDING WASHER FLUID

Visually inspect the fluid level in the washer fluid reservoir.

If washer fluid needs to be added to the reservoir:

1. Lift the washer fluid reservoir cover.
2. Add enough washer fluid to fill the reservoir.

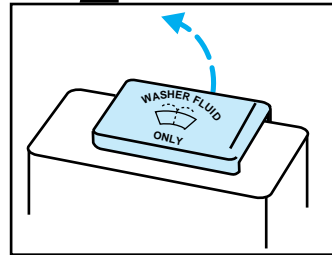
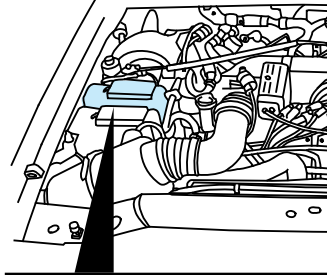

Maintenance and care

Checking and adding washer fluid for the liftgate

The opening for this reservoir is located on the left side of the vehicle above the tail lamp. Be sure to close the cover after filling and before closing the liftgate. The reservoir must be filled slowly to allow trapped air to escape. Use of a funnel is recommended for easier filling.

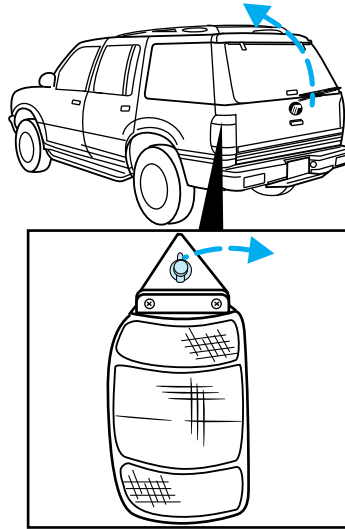

CHECKING AND ADDING ENGINE COOLANT

Check the engine coolant level in the reservoir at least once a month.

If the engine coolant has not been checked for a long period of time, the engine coolant reservoir may eventually empty. If this occurs, add engine coolant to the coolant reservoir. For more information on engine coolant maintenance, refer to *Adding engine coolant to the reservoir* in this chapter.

 Automotive fluids are not interchangeable; do not use engine coolant, antifreeze, or windshield washer fluid outside of their specified function and vehicle location.

When adding engine coolant

Ford recommends Ford Premium Cooling System fluid, which is an optimized formula that will protect all metals and rubber elastomers used in Ford engines for four years

Maintenance and care

or 80,000 km (50,000 miles). It is not necessary and not recommended to use supplemental coolant additives in your gasoline-powered vehicle. These additives may harm your engine cooling system.

When you change or add engine coolant, it is important to maintain your engine coolant concentration between 40% (-24°C [11°F]) and 60% (-52°C [-62°F]), depending on your local climate conditions. A coolant concentration below 40% may cause the engine to overheat on a warm day.

Do not use engine coolant that does not meet all 14 requirements of Ford Specification ESE-M97B44-A. The use of an improper coolant may void your warranty for the engine cooling system. Use only a premium nationally-recognized brand name engine coolant.



Always dispose of used automotive fluids in a responsible manner. Follow your community's standards for disposing of these types of fluids. Call your local recycling center to find out more about recycling automotive fluids.

Adding engine coolant



Never remove the coolant recovery cap while the engine is running or hot.

Maintenance and care

1. Before you remove the coolant recovery cap, turn the engine off and let it cool. Even when the engine is cool, be careful when removing the recovery cap. Wrap a thick cloth around the cap for safe removal.
2. When the engine is cool, lift the cap.
3. Step back while pressure releases.
4. When you are sure that all the pressure has been released, remove the recovery cap.
5. Stand away from the reservoir opening; hot steam may blow out or hot engine coolant may even splash out.
6. Add engine coolant until the level is between the MAX and MIN lines on the engine coolant recovery reservoir.

Follow the recommended service interval for changing engine coolant as outlined in the *Service Guide*. For coolant recovery reservoir capacity, refer to *Lubricant specifications* in the *Capacities and specifications* chapter.

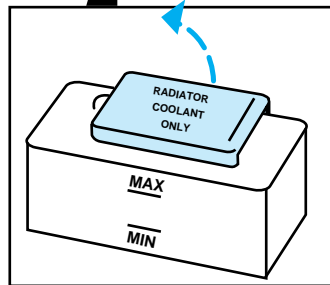
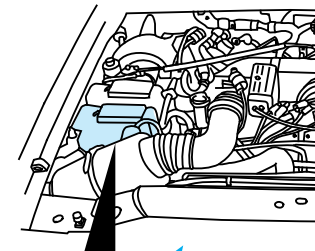

Maintenance and care

Checking the cooling system hoses

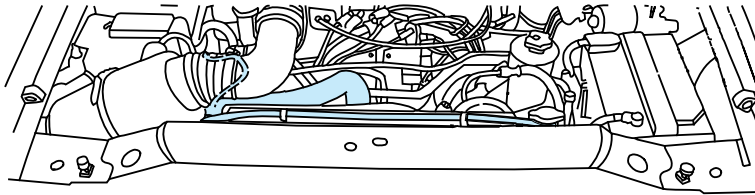

Before adding or replacing coolant, inspect all cooling system hoses for:

- deterioration
- leaks
- loose clamps

CHECKING AND ADDING POWER STEERING FLUID

Check the power steering fluid at least twice a year by completing the following steps:

1. Start the engine.
2. When the engine coolant temperature gauge reaches the normal zone, turn off the engine.

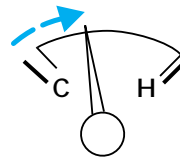

Maintenance and care

3. Visually inspect the fluid level in the power steering reservoir.

4. If necessary, add power steering fluid until the fluid level reaches MAX. Do not overfill the power steering reservoir.

- As a maintenance precaution, visually inspect the lines and hoses of the power steering system for leaks and damage.
- If new fluid is frequently required, consult a qualified service technician.
- Use fluid certified to meet Ford Motor Company lubricant specifications. Refer to *Refill capacities* and *Lubricant specifications* later in this chapter.

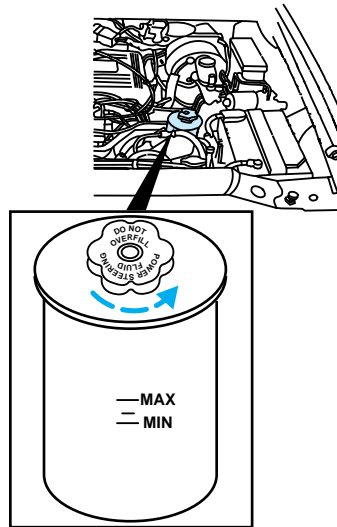

CHECKING AND ADDING AUTOMATIC TRANSMISSION FLUID

Check the automatic transmission fluid according to the scheduled intervals in the *Service Guide*.

Before adding any fluid, make sure the correct type will be used. This information is indicated on the dipstick.



Your vehicle should not be driven if the fluid level is below the bottom hole in the dipstick and outside temperatures are above 10°C (50°F).

Maintenance and care

Your vehicle does not use up transmission fluid. However, it is recommended that you check the transmission fluid at least twice a year. The fluid level should be checked if the transmission is not working properly, i.e., the transmission slips or shifts slowly or if you notice some sign of fluid leakage.

It is preferable to check the transmission fluid level at normal operating temperature, after approximately 32 km (20 miles) of driving. However, if necessary, you can check the fluid level without driving to obtain a normal operating temperature if the outside temperature is above 10°C (50°F).

If the vehicle has been operated for an extended period at high speeds, in city traffic during hot weather or pulling a trailer, the vehicle should be turned off for about 30 minutes to allow the fluid to cool before checking.

1. Park the vehicle on a level surface.
2. Start the engine and move the gearshift lever through all of the gear ranges. Allow sufficient time for each gear to change.
3. Latch the gearshift lever in P(Park), set the parking brake and leave the engine running.
4. Remove the dipstick, wiping it clean with a clean, dry rag.
5. Install the dipstick.



Maintenance and care

6. Remove the dipstick and inspect the fluid level.

The fluid level should be within the crosshatched area, or if the vehicle has not been driven, between the holes near the bottom of the indicator.

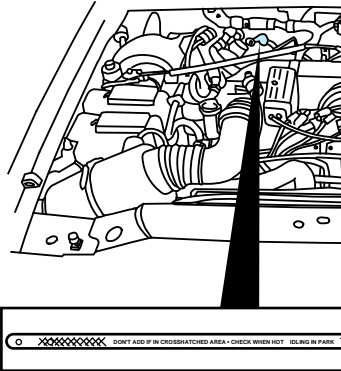

7. If necessary, add fluid in .25 L (1/2 pint) increments through the filler tube until the level is at the correct area on the dipstick. If an overfill occurs, excess fluid should be removed by a qualified technician.

- Use fluid certified to meet Ford Motor Company lubricant specifications. Refer to *Refill capacities* and *Lubricant specifications* later in this chapter.



Always dispose of used automotive fluids in a responsible manner. Follow your community's standards for disposing of these types of fluids. Call your local recycling center to find out more about recycling automotive fluids.

Maintenance and care

Checking and adding transfer case fluid

1. Clean the filler plug.
2. Remove the filler plug and inspect the fluid level.

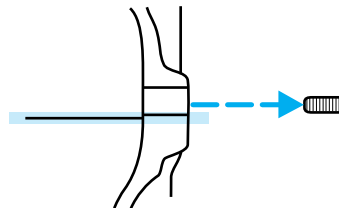
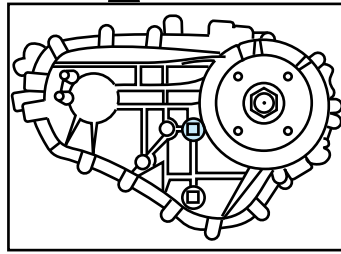
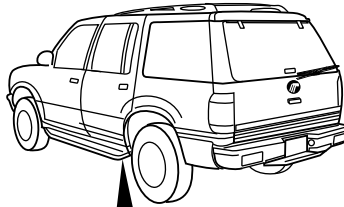

3. Fluid level should be at the bottom of the opening.

When adding transfer case fluid:

- Use fluid certified to meet Ford Motor Company lubricant specifications. Refer to *Refill capacities* and *Lubricant specifications* later in this chapter.

Maintenance and care

- Add only enough fluid through the filler opening so that the fluid level is at the bottom of the opening.

BATTERY

If the original equipment maintenance-free battery needs replacing, it may be replaced with a low-maintenance battery. For information on replacement batteries, refer to *Motorcraft part numbers* in the *Capacities and specifications* chapter.

 Batteries normally produce explosive gases that can cause personal injury. Do not allow flames, sparks, or lit smoking materials to come near the battery. When charging or working near a battery, always cover your face, protect your eyes, and provide ventilation.

 Batteries contain sulfuric acid that can burn skin, eyes, and clothing.

 Applying too much pressure on the ends when lifting a battery could cause acid to spill. Lift the battery with a carrier or with your hands on opposite corners.

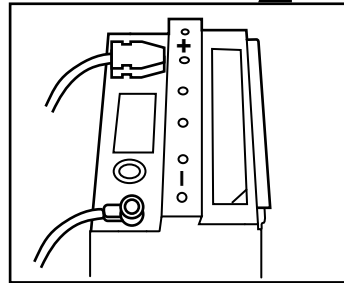
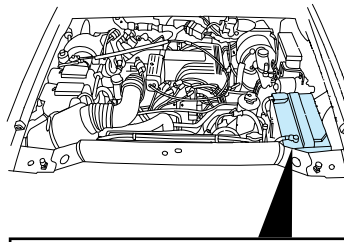

Servicing your battery

The low-maintenance battery has removable vent caps for checking

Maintenance and care

the electrolyte level and adding water. Check the electrolyte level every 24 months or 40,000 km (24,000 miles) in average temperatures 32°C (90°F). Keep the electrolyte level in each cell up to the level indicator. Do not overfill.

If the level gets low, refill the battery with distilled water. If necessary, distilled water may be substituted with tap water that is not hard and does not have a high mineral or alkali content. If the battery needs water quite often, have the charging system checked for a possible malfunction.

Your vehicle is equipped with a battery saver control feature designed to prevent your battery from accidental wear down due to doors left ajar. For information on the system and how it works, see *Interior overhead lamp* in the *Controls and features* chapter.

Because your vehicle's engine is electronically controlled by a computer, some control conditions are maintained by power from the battery. When the battery is disconnected or a new battery is installed, the computer must "relearn" its idle conditions before your vehicle will drive properly. To begin this process:

1. Put the gearshift in P (Park).
2. Turn off all accessories, and start the vehicle.

Maintenance and care

3. Let the engine idle for at least one minute.
4. The relearning process will automatically complete as you drive the vehicle.
 - If you do not allow the engine to relearn its idle, the idle quality of your vehicle may be adversely affected until the idle is eventually relearned.
 - If the battery has been disconnected or a new battery has been installed, the clock and preset radio stations must be reset once the battery is reconnected.
 - Always dispose of used automotive batteries in a responsible manner. Follow your community's standards for disposal. Call your local recycling center to find out more about recycling automotive batteries.

Maintenance and care

Changing your air filter

1. Loosen the clamp that secures the air cleaner in place. Separate the two halves of the air cleaner.

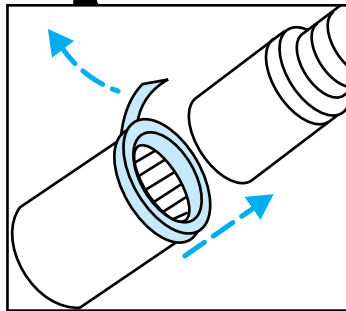
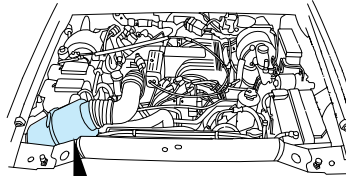

2. Remove the air filter element from the open end of the engine air cleaner and replace it with a new element.

3. Replace the two halves of the air cleaner and secure the clamp.

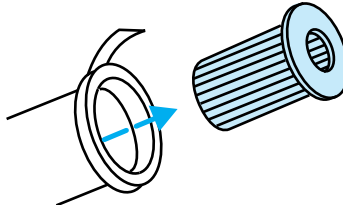

CHECKING AND CHANGING WIPER BLADES

Check the windshield wiper blades at least twice a year or whenever the wipers seem less effective than usual. Substances such as tree sap and some hot wax treatments used by commercial car washes can reduce the effectiveness of wiper blades.

Maintenance and care

To make reaching the wiper blades easy, simply turn the ignition to the ON position and turn the wipers on. Wait for them to reach a vertical position and turn the ignition to LOCK. Do not move the wipers manually across the windshield as this may cause damage to the wipers.

Inspect the wiper arm pivots on a regular basis to ensure that the wiper arms move freely. Lubricate the pivot points as necessary.

Replacing wiper blades

If the wiper blades do not work properly after cleaning, replacement of the blade assembly or the blade element may be necessary.

There are two different length wiper blades on your vehicle. The windshield wiper blades are 45 cm (17.75 in) long and the liftgate wiper is 34.9 cm (13 3/4 in) long. Make sure you install the correct size wiper blade in the correct location.

To replace windshield wiper blades:

1. Pull the wiper arm away from the windshield and lock it into the service position.
2. Turn the blade at an angle from the wiper arm. Depress lock tab and push wiper mounting arm away from wiper blade assembly.
3. Attach the new wiper blade by pulling wiper mounting arm down

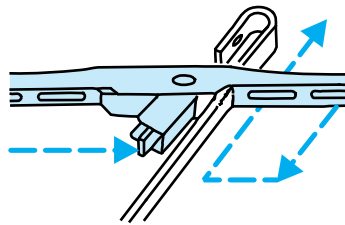

Maintenance and care

on wiper blade until lock tab is engaged.

To replace liftgate wiper blade:

1. Pull wiper arm away from liftgate window.
2. Use small screwdriver to depress lock tab and pull wiper blade upwards and away from wiper arm.
3. Attach new wiper blade by pushing wiper arm post through hole in wiper blade until lock tab is engaged.

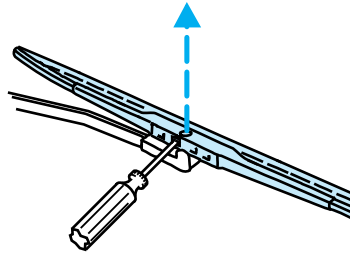

Information about tire grades

New vehicles are fitted with tires that have their Tire Quality Grade (described below) molded into the tire's sidewall. These Tire Quality Grades are determined by standards that the United States Department of Transportation has set.

Tire Quality Grades apply to new pneumatic tires for use on passenger cars. They do not apply to deep tread, winter-type snow tires, space-saver or temporary use spare tires, tires with nominal rim diameters of 25.4 cm to 30.48 cm (10 to 12 in.) or limited production tires as defined in Title 49 Code of Federal Regulations Part 575.104(c)(2).

U.S. Department of Transportation
- Tire quality grades: The U.S. Department of Transportation requires Ford to give you the following information about tire

Maintenance and care

grades exactly as the government has written it.

Treadwear

The treadwear grade is a comparative rating based on the wear rate of the tire when tested under controlled conditions on a specified government test course. For example, a tire graded 150 would wear 1½ times as well on the government course as a tire graded 100. The relative performance of tires depends upon the actual conditions of their use, however, and may depart significantly from the norm due to variations in driving habits, service practices, and differences in road characteristics and climate.

Traction A B C

The temperature grades, from highest to lowest, are A, B and C. These grades represent the tire's ability to stop on wet pavement as measured under controlled conditions on specified government test surfaces of asphalt and concrete. A tire marked C may have poor traction performance.



The traction grade assigned to this tire is based on braking (straight ahead) traction tests and does not include cornering (turning) traction.

Maintenance and care

Temperature A B C

The temperature grades, from highest to lowest, are A, B and C. These grades represent the tire's resistance to the generation of heat and its ability to dissipate heat when tested under controlled conditions on a specified indoor laboratory test wheel. Sustained high temperature can cause the material of the tire to degenerate and reduce tire life, and excessive temperature can lead to sudden failure. The grade C corresponds to a level of performance which all passenger tires must meet under the Federal Motor Vehicle Safety Standard No. 109. Grades A and B represent higher levels of performance on the laboratory test wheel than the minimum required by law.



The temperature grade for this tire is established for a tire that is properly inflated and not overloaded. Excessive speed, under inflation, or excessive loading, either separately or in combination, can cause heat build up and possible tire failure.

SERVICING YOUR TIRES

Checking the tire pressure

Check the tire pressure at least once a month or after rotating tires and inflate tires as necessary. Tire pressure is most accurate

Maintenance and care

when tires are cold (after the vehicle has been parked for at least one hour or driven less than 5 km (3 miles)).

The cold pressure amount is listed on the Safety Compliance Certification Label located on the inside driver's door latch pillar.



Improperly inflated tires can affect vehicle handling and can fail suddenly, possibly resulting in loss of vehicle control.

Rotating your tires

Rotate your tires at regular intervals to ensure even wear. Rotation intervals are listed in the *Service Guide*.

Your wheels and tires are match-mounted for improved ride. Before you begin a tire repair, mark the wheel and tire to ensure proper alignment when remounting.

Maintenance and care

Four tire rotation

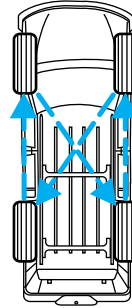

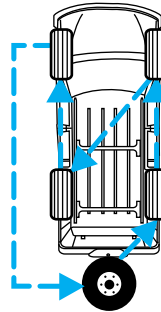

Five tire rotation



Replacing the tires

Replace the tires when the wear band is visible through the tire treads.

 When replacing full size tires, never mix radial bias belted or bias-type tires. Use only the tire sizes that are listed on the tire pressure decal.

 Make sure all replacement tires are of the same size, type, load-carrying capacity, and tread design, e.g., "All Terrain", as originally offered by Ford.

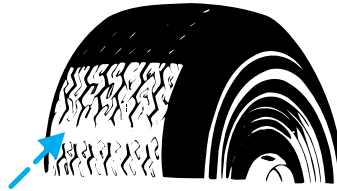

Maintenance and care



Failure to follow these precautions may adversely affect the handling of the vehicle and make it easier to lose control and roll over.

IDENTIFYING TIRE TYPES

Refer to the Safety Compliance Certification Label to determine the specific size tire and wheel Ford Motor Company recommends for use on this vehicle.

All wheel/tire combinations (including spare) must be the same size for AWD equipped vehicles.

SNOW TIRES AND CHAINS



Snow tires must be the same size and grade as the tires you currently have on your vehicle.

The tires on your vehicle have all weather treads to provide traction in rain and snow. However in some climates, you may need to use snow tires and chains. Follow these guidelines when using snow tires and chains:

- Use only SAE Class “S” chains.
- Install chains securely, verifying that the chains do not touch any wiring, brake lines or fuel lines.
- Install tire chains on rear tires only.

Maintenance and care

- Drive cautiously. If you hear the chains rub or bang against your vehicle, stop and re-tighten the chains. If this does not work, remove the chains to prevent damage to your vehicle.
- If possible, avoid fully loading your vehicle.
- Remove the tire chains when they are no longer needed. Do not use tire chains on dry roads.
- The suspension insulation and bumpers will help prevent vehicle damage. Do not remove these components from your vehicle when using snow tires and chains.

WHAT YOU SHOULD KNOW ABOUT AUTOMOTIVE FUEL





Do not overfill the fuel tank. The pressure in an overfilled tank may cause leakage and lead to fuel spray and fire.



If you do not use a proper fuel cap, the pressure in the fuel tank can damage the fuel system or cause it to work improperly in a collision.

Maintenance and care

 If you replace your fuel cap with an aftermarket fuel filler cap, the customer warranty may be void if any damage to the fuel tank and/or fuel system occurs.

 If the fuel cap is venting vapor or you hear a hissing sound, wait until it stops before completely removing the cap.

 Automotive fuels can cause serious injury or death if misused or mishandled.

Extinguish all smoking materials and any open flames before fueling your vehicle.

Automotive fuels can be harmful or fatal if swallowed. If fuel is swallowed call a physician immediately, even if no symptoms are apparent. The toxic effects of fuels may not be visible for many hours.

Fuels can also be harmful if absorbed through the skin. If fuel is splashed on the skin, promptly remove contaminated clothing and wash skin thoroughly with soap and water.

If fuel is splashed in the eyes, remove contact lenses, flush with plenty of water for 15 minutes, and seek medical attention.

Be particularly careful if you are taking “Antabuse” or other forms

Maintenance and care

of disulfiram for the treatment of alcoholism. Breathing gasoline vapors or skin contact could possibly cause an adverse reaction. Consult a physician immediately.

Cleaner air

Ford approves the use of gasolines to improve air quality, including reformulated gasolines, that contain oxygenates such as a maximum of 10% ethanol or 15% MTBE. There should be no more than 5% methanol with cosolvents.

Octane recommendations

Your vehicle is designed to use regular gasoline with an (R+M)/2 octane rating of 87. We do not recommend gasolines labeled as "regular" in high altitude areas that are sold with octane ratings of 86 or even less.

Do not be concerned if your vehicle sometimes knocks lightly. However, if it knocks heavily under most driving conditions on the recommended octane fuel, see your dealer or a qualified service technician to prevent any engine damage.

Fuel quality

If you are experiencing starting, rough idle or hesitation problems try a different brand of fuel. If the condition persists, see your dealer or a qualified service technician.

The American Automobile Manufacturers Association (AAMA)

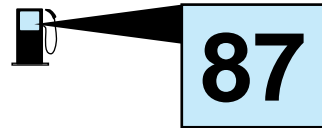

Maintenance and care

issued a gasoline specification to provide information on high quality fuels that optimize the performance of your vehicle. We recommend the use of gasolines that meet the AAMA specification if they are available.

It should not be necessary to add any aftermarket products to your fuel tank if you continue to use a high-quality fuel.

Choosing the right fuel

Use only UNLEADED FUEL. The use of leaded fuel is prohibited by law and could damage your vehicle. The damage may not be covered by your warranty.

Your vehicle was not designed to use fuel containing manganese-based additives such as MMT. Additionally, vehicles certified to California emission standards (indicated on the underhood Vehicle Emissions Control Information label) are designed to operate on California reformulated gasolines. If California reformulated gasoline is not available when you refuel, your vehicle can be operated on non-California fuels. However, even though your engine will perform adequately on other gasolines, the performance of the emission control devices and systems may be adversely affected. Repair of damage caused by using a fuel that your vehicle was not designed for may not be covered by your warranty.

Maintenance and care

Calculating fuel economy

1. Fill the tank completely and record the initial odometer reading.
2. Each time you fill the tank, record the amount of fuel added (in liters or gallons).
3. After at least three to five fuel tank fill-ups, fill the fuel tank and record the final odometer reading.

Keep a record for at least one month. This will provide an accurate estimate of the vehicle's fuel economy.

4. Use one of the following equations to calculate fuel economy:

Liters used x 100 ÷ Total kilometers travelled

Total miles travelled ÷ Total gallons used

The fuel economy figures provided by the Environmental Protection Agency (EPA) and Transport Canada (TC) are obtained from laboratory tests under simulated road conditions and may not reflect actual road conditions or individual driving styles. The EPA fuel economy estimate is not a guarantee, but a guideline of projected fuel economy.

WHAT YOU SHOULD KNOW ABOUT THE EMISSION CONTROL SYSTEM

Your vehicle is equipped with a catalytic converter which enables

Maintenance and care

your vehicle to comply with applicable exhaust emission requirements. For more information on your vehicle's emission control system, see the Vehicle Emission Control Information decal located on the left side of the engine compartment.

Follow these guidelines to ensure proper emission system operation:

- Use only unleaded fuel.
- Avoid running out of fuel.
- Do not turn off the ignition while your vehicle is in motion.
- Have the services performed according to the intervals in the *Service Guide*.

When servicing your vehicle, never use a metal exhaust collector. A metal collector may melt or deform plastic parts.



Do not park, idle, or drive your vehicle in dry grass or other dry ground cover. The emission system heats up the engine compartment and exhaust system, which can start a fire.



On vehicles without original equipment floor covering or insulation, do not let passengers ride in your truck in a manner that allows contact between skin and the metal floor.

Maintenance and care

If you notice one or more of the following, the emission system may not be working properly. Have the vehicle serviced as soon as possible.

- Fluid leaks.
- The  and CHECK ENGINE lights illuminate in the instrument cluster and remain lit.
- Strange odors.
- Engine runs more than five seconds after shut-off or engine misfires, surges, stalls or backfires.
- Loss of oil pressure.

When servicing your vehicle, never use a metal exhaust collector. A metal collector may heat or deform plastic parts.

Important emission control information

By law, anyone who manufactures, repairs, services, sells, leases, trades vehicles, or supervises a fleet of vehicles is not permitted to intentionally remove an emission control device or prevent it from working.

Do not make any unauthorized changes to the vehicle or engine. Changes that cause more unburned fuel to reach the exhaust system can increase the temperature of the engine or exhaust system.

Maintenance and care

Preparing your vehicle for inspection/maintenance testing

In some localities it may become a legal requirement to pass an Inspection/Maintenance test of the On-Board Diagnostic (OBD II) system. If the vehicle's powertrain system or battery has just been serviced, the OBD II system is reset to a not ready for I/M testing condition. To ready the OBD II system for I/M testing, the law specifies that additional mixed city and highway driving is necessary to complete the check of the OBD II system.

The driving modes required to reach the ready condition consist of a minimum of 30 minutes of city and highway driving as described below:

- 20 minutes of driving in stop and go city-type traffic with at least four idle periods.
- 10 minutes of driving on an expressway or highway.

Before completing the above driving modes, the engine must be warmed up and at operating temperature. Once started, the vehicle must not be turned off during the above driving modes. If the vehicle owner is unable to meet the I/M requirements by using these driving patterns, an authorized service center can perform a detailed OBD II Drive Cycle as it would any other type of repair work.

Maintenance and care

EXTERIOR LAMPS

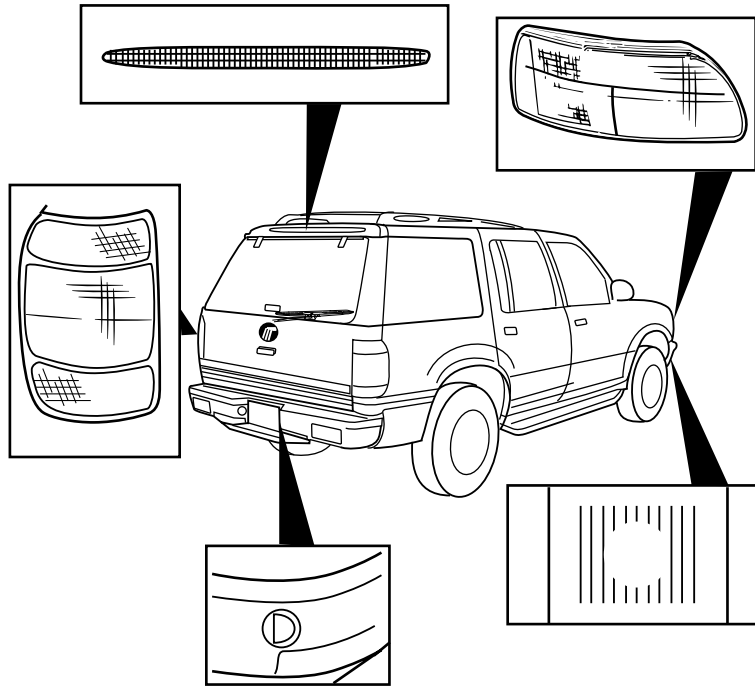

Replacing the exterior bulbs

It is a good idea to check the operation of the following lights frequently:

- Headlamps
- High-mount brakelamp
- Tail lamps
- Brakelamps
- Backup lamps
- Hazard flasher

Maintenance and care

- Turn signals
- License plate lamp
- Fog lamps
- Interior overhead lamp

Do not remove lamp bulbs unless they will be replaced immediately. If a bulb is removed for an extended period of time, contaminants may enter the lamp housings and affect performance.

Headlamps

 Handle a halogen bulb carefully and keep out of children's reach. Grasp the bulb only by its plastic base and do not touch the glass; the oil from your hand could cause the bulb to break the next time that the headlamps are operated.

1. Make sure that the headlamp switch is in the OFF position.
2. Lift the hood and open the hinged headlamp cover.

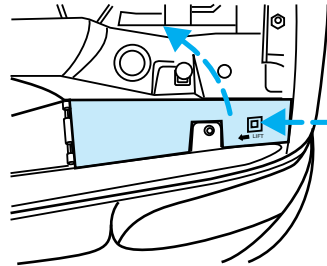

Maintenance and care

3. Remove electrical connector by grasping wires and pulling rearward.

4. Remove bulb retaining ring by turning it 1/8 turn to free it from the socket. Slide the ring off the plastic base.

5. Carefully remove the bulb assembly from its socket by gently pulling it rearward.

6. With the flat side of the bulb's plastic base facing upward, insert the glass end of the bulb into the socket. You may need to turn the bulb left or right to line up the grooves in the plastic base with the tabs in the socket.

7. Slip the bulb retaining ring over the plastic base and lock it by rotating it clockwise until you feel it stop.

8. Push the electrical connector into the rear of the plastic base until you feel it "snap."

9. Replace the bulb assembly into the headlamp.

High-mount brakelamp

The high-mount brakelamp is located just above the rear liftgate window. For bulb replacement, see your dealer.

Rear turn signals/brake/tail lamps/backup lamps

The tail lamps, backup lamps and the brake lamps are located in the same bezel. Follow these steps to

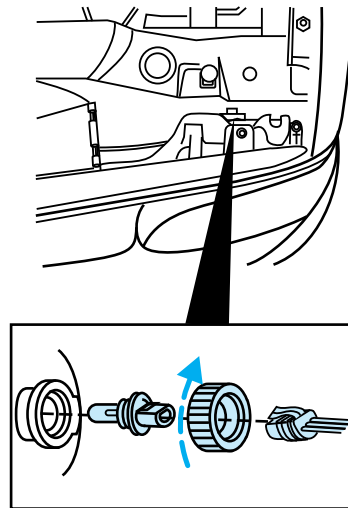

Maintenance and care

remove and replace any of the bulbs.

1. Remove the two (2) screws retaining rear lamp to vehicle.
2. Remove rear lamp by pulling rearward to disengage two lower barbed retainers.

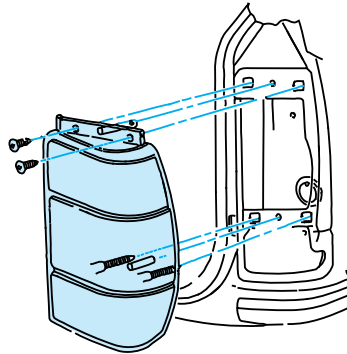

3. Remove socket from lamp.
4. Remove bulb from socket.
5. Install bulb in socket.
6. Install socket to lamp.
7. Replace rear lamp.

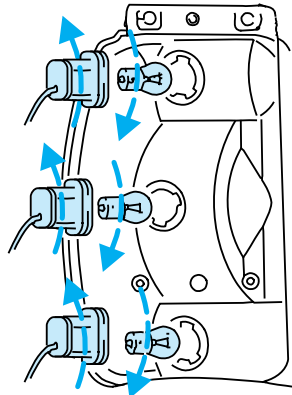

Hazard flasher

For more information on the hazard flasher and hazard switch, refer to *Hazard switch* in the *Roadside emergencies* chapter. For bulb replacement, see your dealer.

Maintenance and care

Turn signals

For more information on the turn signals, refer to *Turn signals* in the *Controls and Features* chapter. For bulb replacement, see your dealer.

License plate lamp

To change the license plate bulb, follow this procedure:

1. Use a screwdriver to detach the lamp from the bumper.
2. Turn and pull the socket from the lamp and remove the bulb.
3. Replace socket into lamp and press lamp back into bumper.

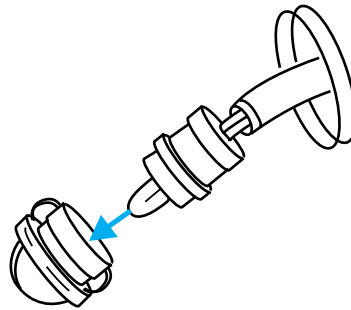

Maintenance and care

Fog lamps

1. Disconnect the electrical connector from the back of the foglamp by turning it counterclockwise.
2. Remove bulb by lifting retaining clip and pulling the bulb from the assembly.
3. Replace the bulb and insert the bulb assembly back into the foglamp.
4. Lock bulb assembly into place by turning it clockwise until it stops.

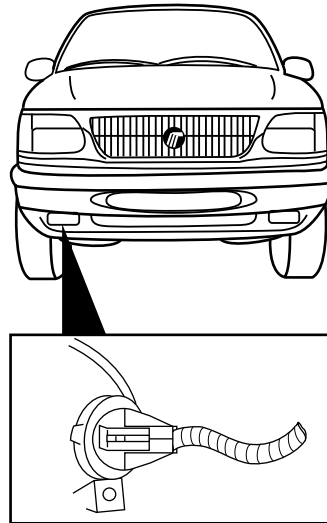

Interior overhead lamp

The interior overhead lamp is located in the overhead console. To change the bulb, follow this procedure:

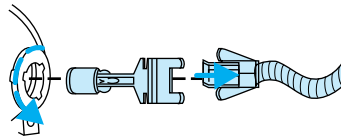

Maintenance and care

1. To remove the lens, pry with a small screwdriver as shown.

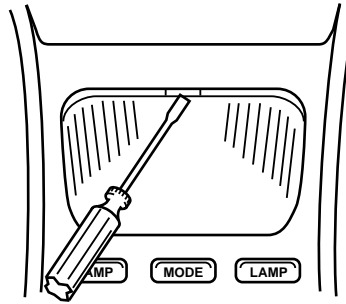

2. To remove the bulbs, rotate bulb holder counterclockwise 90°. The bulb and bulb holder will drop out.

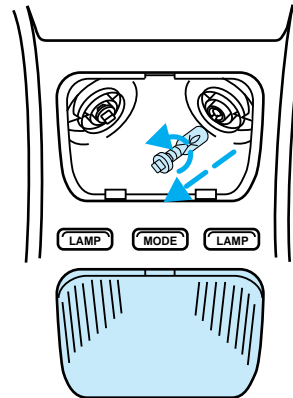

3. Pull bulb from bulb holder. Insert new bulb.

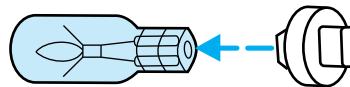

4. To replace the bulb holder, push up and rotate clockwise 90°.

5. Replace lens.

Maintenance and care

BULB SPECIFICATIONS

Description	Number of Bulbs	Trade Number
<i>Exterior Illumination</i>		
Headlamps	2	9007
Front lamp and turn signal	4	3157NA*
Front side marker lamp	2	916NA*
Underhood lamp	1	906
Fog lamps	2	H3
<i>Rear Lamps - Exterior</i>		
Rear back-up lamp	2	3156
High-mount brakelamp	1	²
License plate lamp	2	194
Rear tail/brake lamp	2	3157
Turn lamp	2	3156
<i>Interior Courtesy Lamps</i>		
Cargo lamp	1	211-2
Dome lamp (low series)	1	912
Dome lamp (high series)	1	906
Map lamps	2	168
Map lamps with overhead console (if equipped)	2	T10
Front door courtesy lamp	1	168
Deluxe map reading lamp/dome	2	168
Instrument panel illumination	1	906

Maintenance and care

Description	Number of Bulbs	Trade Number
<i>Radio Illumination¹</i>		
<i>Instrument Panel</i>		
Ashtray lamp	1	161
Glove compartment lamp	1	194
Instrument cluster	1 each	194
<i>Instrument Panel Controls</i>		
A/C controls	1	161
Rear window wiper/washer control	1	²
Headlamp controls	1	1815
Heater controls	1	161

¹Replaceable at Lincoln/Mercury and Ford authorized radio service centers.

²See your dealer for bulb replacement.

* Natural amber

Aiming headlamps

The alignment of your headlamps should be checked if:

- Oncoming motorists frequently signal you to turn off your vehicle's high beams when you do not have the high beams on.
- The headlamps do not seem to give you enough light to see clearly at night.
- The headlamp beams are pointed substantially away from a position slightly down and to the right.

Maintenance and care

See your Lincoln/Mercury or Ford dealer for precise adjustment of your headlamps.

CLEANING AND CARING FOR YOUR VEHICLE

Washing your vehicle

Wash your vehicle regularly with cold or lukewarm water. Never use strong detergents or soap. If your vehicle is particularly dirty, use a quality car wash detergent. Always use a clean sponge and plenty of water for best results. We recommend that you have the underbody of your vehicle washed at the end of the winter to remove deposits left by snow, salt and water.

Remove any aftermarket accessories, such as antennas, before entering a car wash.

After washing your vehicle, apply the brakes several times to dry them.

Wax the paintwork of your vehicle once or twice a year. This will help retain the glossy finish and water droplets will run off more easily.

Repairing paint chips

Minor scratches or paint damage from road debris may be camouflaged with touch-up paint, paint repair foil, or aerosol paint spray from the Ford Accessory line. Observe the application instructions on the products. In order to retain the vehicle

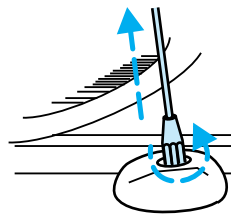
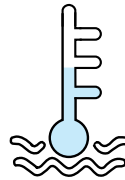

Maintenance and care

warranty on paperwork, remove aggressive particles such as bird droppings, tree sap, insect remains, tar spots, road salt, and industrial fallout immediately.

Cleaning the wheels

Wash the wheels with the same detergent you use to clean the body of your vehicle. Do not use acid based wheel cleaners, steel wool, fuel, or strong detergents. Never use abrasives that will damage the finish of special wheel surfaces. Use a tar and road oil remover to remove grease and tar.

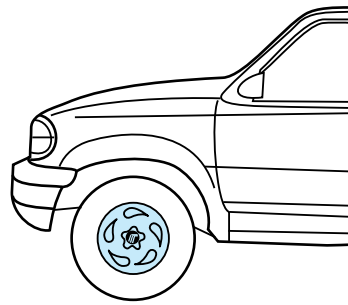

Cleaning plastic parts

Some of your vehicle's trim parts are plastic. Clean with a tar and road oil remover if necessary. Use a vinyl cleaner for routine cleaning. Do not clean plastic parts with thinners, solvents or petroleum based cleaners.

Cleaning the instrument panel

Any cleaner or polish that increases the gloss of the upper portion of the instrument panel should be avoided. The dull finish in this area is to help protect the driver from undesirable windshield reflection.

Cleaning the exterior lamps

Do not use dry paper towel, chemical solvents, or abrasive cleaners to clean the lamps; these products may cause scratches or crack the lamps.

Maintenance and care

Cleaning the engine

A clean engine is more efficient than a dirty one because a buildup of grease and dirt acts as an insulator and keeps the engine warmer than normal. Follow these guidelines to clean your engine:

- Take care when using a power washer to clean the engine. The high pressure fluid could penetrate the sealed parts and cause damage.
- In order to avoid cracking the engine block, do not spray with cold water.
- The alternator, ignition coil packs, and air intake must be covered to prevent water damage when cleaning the engine.
- Never wash or rinse the engine while it is running; water in the running engine may cause internal damage.

Cleaning the wiper blades

If the wiper blades do not wipe properly, clean both the windshield and the wiper blades using undiluted windshield washer solution or a mild detergent. Rinse thoroughly with clean water. Do not use fuel, kerosene, paint thinner, or other solvents to clean your wiper blades; these fluids will damage your blades.

Maintenance and care

Cleaning the built-in child seat

Clean the built-in child seat with mild soap and water. Do not use household cleaning products because they may weaken the safety belt webbing or damage the vinyl parts of the seat.

The child seat liner is removable and may be machine-washed and air dried.

Cleaning and maintaining the safety belts

Clean the safety belts with a mild soap solution recommended for cleaning upholstery or carpets. Do not bleach or dye the belts, because these actions may weaken the belt webbing.

Check the safety belt system periodically to make sure there are no nicks, wear or cuts. If your vehicle has been involved in an accident, have all the safety belts and child seat anchoring brackets (if equipped) examined by a qualified technician.

Capacities and specifications

MOTORCRAFT PART NUMBERS

Component	Motorcraft part number
Spark plug ¹	AWSF-32EE*
Air filter	FA-1641
Fuel filter	FG-872
Oil filter	FL-1A
Battery	BXT-65-650 or BXT-65-850 (optional)
P.C.V. valve	EV-152

¹Refer to Vehicle Emission Control Information Decal for spark plug and gap specifications.

*If any spark plug needs to be removed for examination, each spark plug removed must be reinstalled in the same cylinder. Cylinders 1-4 have an "EG" suffix. Cylinders 5-8 have an "E" suffix. If any spark plug needs to be replaced, use only spark plugs with the service part number suffix letters "EE" as shown on the engine decal.

REFILL CAPACITIES

Fluid	Component	Capacity
Brake fluid	Brake master cylinder	Fill to line in reservoir ¹
Engine coolant	Engine coolant recovery reservoir and radiator	13.5 L (12.8 qts.)
Engine oil	5.0 L (302 c.i.d.)	4.7 L (5.0 qts.) ²
Fuel	4-door	79.5 L (21.0 gal)
Front axle	Dana 35 front axle	1.7 L (3.5 pts.) ¹
Power steering fluid	Power steering fluid reservoir	Fill to line in reservoir ¹
Rear axle	Ford conventional and Traction Lok 8.8	2.6 L (5.5 pts.) ¹

Capacities and specifications

Fluid	Component	Capacity
Transfer case fluid (if equipped)	Borg Warner AWD transfer case	1.25 L (2.64 pts.)
Transmission fluid, automatic	Automatic 4R70W (2WD and AWD)	13.2 L (13.9 qts.)
Windshield washer fluid, front	Front washer fluid reservoir	2.6 L (2.8 qts.)
Windshield washer fluid, rear	Liftgate washer fluid reservoir	3.1 L (3.3 qts.)

¹Fill to 6-15 mm (1/4" to 9/16") from the bottom of the filler hole.

²Includes 1 L (1 qt.) for filter replacement.

³All rear axle lube quantities must be replaced every 160,000 km (100,000 miles) or if the axle has been submerged in water. Otherwise, the lube should not be checked or changed unless a leak is suspected or repair required. Refer to the *Service Guide*.

Capacities and specifications

LUBRICANT SPECIFICATIONS

Component	Ford part name	Ford part number	Ford specification
Windshield washer reservoir	Ultra-Clear Windshield Washer Concentrate	C9AZ-19550-AA or BA	ESR-M17P5-A
Body hinges, latches, door striker plates and rotors, seat tracks, door checks and tracks, hood latch, auxiliary latch, and fuel filler door and spring	Multi-Purpose Grease	D0AZ-19584-AA or D7AZ-19584-AA	ESB-M1C93-A or ESB-M1C159-A
Steering column, U-joints, clutch linkage pivots, parking brake linkage pivots and clevises and transmission control linkage pivots	Premium Long-Life Grease	XG-1C or K	ESA-M1C75-B
Brake master cylinder	High Performance DOT 3 Brake Fluid	C6AZ-19542-AA or BA	ESA-M6C25-A

Capacities and specifications

Component	Ford part name	Ford part number	Ford specification
Engine oil	Motorcraft Motor Oil 5W-30 Super Premium	X0-5W30 QSP	WSS-M2C153-F with API Certification mark
Door weatherstrips	Silicone Lubricant	C0AZ-19553-AA	ESR-M13P4-A
Automatic transmission shift linkage and brake pedal shaft	Premium Long-Life Grease	XG-1-C or K	ESA-M1C75-B
Automatic transmission 4R70W	Motorcraft MERCON® ATF	XT-2-QDX	MERCON®
Power steering reservoir	Motorcraft MERCON® ATF	XT-2-QDX	MERCON®
Parking brake cable	Speedometer Cable Lubricant	E6TZ-19581-A	ESF-M1C160-A
Accelerator throttle lever ball stud	Premium Long-Life Grease	XG-1-C or K	ESA-M1C75-B
Ford conventional and Traction-Lok rear axles ¹	Motorcraft 75W/40 Premium Synthetic Rear Axle Lubricant	XY-80W90-QL	WSP-M2C197-A
Drive shaft, universal joints and slip spines	Premium Long-Life Grease	XG-1-C or K	ESA-M1C75-B

Capacities and specifications

Component	Ford part name	Ford part number	Ford specification
Engine coolant	Premium Cooling System Fluid	E2FX-19549-AA	ESE-M97B44-A
Transfer case front output slip shaft	Premium Long-Life Grease	XG-1-C or K	ESA-M1C75-B
Transfer case	Motorcraft MERCON® ATF	XT-2-QDX	MERCON®
Dana 35 front drive axle	4x4 Gear Oil	F1TZ-19580-A	WSL-M2C191-A

¹Add 118 ml (4oz.) of EST-M2C118-A Friction Modifier (part number C8A2-19B546-A) for complete refill of Ford Traction-Lok rear axles.

ENGINE DATA

Engine	5.0L (302 CID) OHV V-8
Displacement	5.0L (302 CID)
Bore x Stroke	10.16 x 7.62 cm (4.00 x 3.00 in.)
Induction	PCM controlled sequential port fuel injection
Ignition	PCM controlled distributorless electronic
Firing order	1-3-7-2-6-5-4-8
Spark plug gap	1.3 - 1.4 mm (.052 - .056 in.)
Horsepower	210 HP
Torque	366.1 N·m (270 lb/ft)
Compression ratio	8.8:1

Capacities and specifications

VEHICLE DIMENSIONS

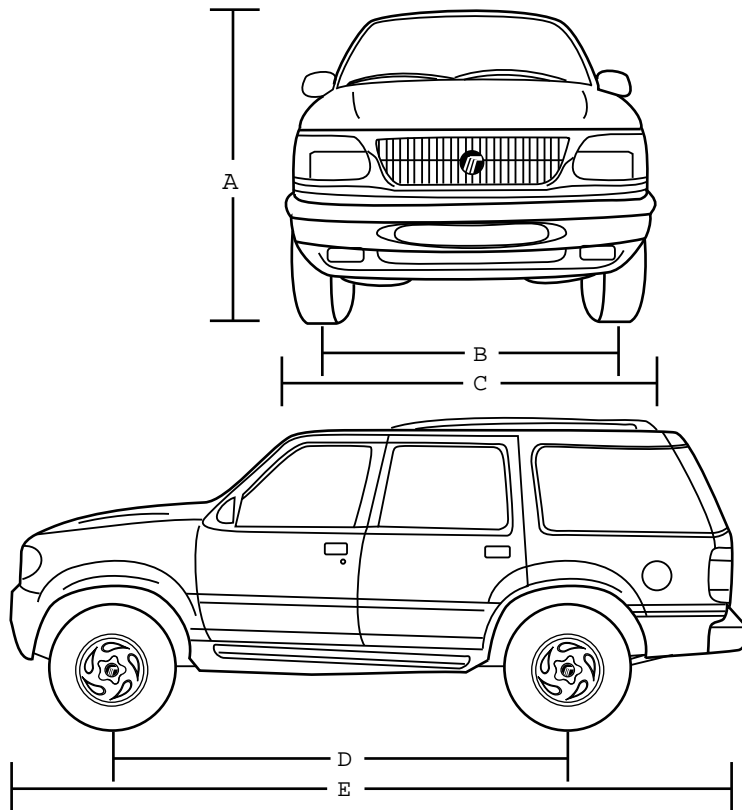

Dimensions

A = Overall height	1.83 m (67.3 in.)
B = Track front/rear	1.49 m (58.3 in.)
C = Overall width (excluding mirrors)	1.87 m (70.2 in.)
D = Wheelbase	2.83 m (111.9 in.)
E = Overall length	4.78 m (184.3 in.)

Capacities and specifications

**VEHICLE IDENTIFICATION
NUMBER (VIN)**

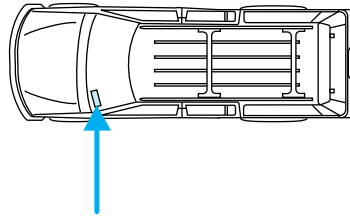

Reporting safety defects

If you believe that your vehicle has a defect which could cause a crash, or could cause injury or death, you should immediately inform the National Highway Traffic Safety Administration (NHTSA) in addition to notifying Ford Motor Company.

If NHTSA receives similar complaints, it may open an investigation, and if it finds that a safety defect exists in a group of vehicles, it may order a recall and remedy campaign. However, NHTSA cannot become involved in individual problems between you, your dealer, or Ford Motor Company.

To contact NHTSA, you may either call the Auto Safety Hotline toll-free at 1-800-424-9393 (or 366-0123 in the Washington, D.C. area) or write to:

NHTSA
U.S. Department of Transportation
400 Seventh Street
Washington, D.C. 20590

You can also obtain other information about motor vehicle safety from the Hotline.

Index

- Air bag supplemental restraint system71,74,75,76,77,82,87
 - and child safety seats74,76,77,82,87
 - description73
 - indicator light74
- Air cleaner filter
 - replacing156
- All Wheel Drive102
- Anti-theft system56
 - arming the system56
 - disarming a triggered system ..57
 - disarming an untriggered system57
- Audio system (see Electronic sound system)16
- Autolamp system (see Headlamps)33
- Automatic transmission98
 - fluid, adding149
- Battery153
 - battery saver58
 - how to service153
- Brake fluid
 - checking and adding142
- Brakelamp
 - bulb replacement174
- Brakes97
 - adjustment96
 - anti-lock96
 - anti-lock brake system (ABS) warning light97
 - parking97
- Break-in period3
- Bulbs, replacing
 - specifications179
- Cargo area shade46,47
- Cargo cover46,47
- Childproof locks39
- Chime11
 - headlamps on12
 - key-in-ignition11
 - safety belt11,69
- Cleaning your vehicle
 - built-in child seat184
 - engine compartment183
 - exterior182
 - instrument panel182
 - plastic parts182
 - safety belts184
 - washing181
 - wheels182
 - wiper blades183
- Climate control system17,18,19,21
 - air conditioning21
 - heating21
- Compass, electronic
 - calibration30
 - set zone adjustment30
- Compass/temperature display ..29
- Console, description42
- Controls
 - instrument panel13
 - steering column22
- Daytime running light system ..14
- Defects, reporting192
- Defrost
 - rear window15
- Driving under special conditions
 - towing a trailer114
- Electronic sound system16
- Emission control system168
- Engine139,189
- Engine block heater93
- Engine coolant
 - checking and adding145
 - checking hoses148
- Engine coolant temperature gauge7
- Engine oil
 - checking and adding140,142
- Exhaust fumes94

Index

- Flat tire131
- Fluid refill capacities185
- Foglamps16,177
- Fuel
 - calculating fuel economy167
 - choosing the right fuel166
 - improving fuel economy116
 - safety information relating to
 - automotive fuels164
- Fuel gauge7
- Fuel pump shut-off switch ..16,118
- Fuse panels120
 - power distribution box124
- Fuses119
 - charts120
 - checking and replacing121
- Gauges, Mechanical
 - battery voltage gauge7
 - engine coolant temperature gauge7
 - engine oil pressure gauge7
 - fuel gauge7
 - odometer7
 - speedometer6
 - tachometer6
 - trip odometer7
- Hazard flashers27,118,175
- Headlamps13
 - autolamp system13,33
 - daytime running lights14
 - warning chime12
- Hitch112
- Hood138
- Ignition
 - positions of the ignition22
- Inspection/maintenance (I/M) testing170
- Instrument cluster6,7,8,9,11,12,13,14,15,16,17,18,19,21
- Instrument panel13
 - location of components4,5
- Jump-starting your vehicle132
- Keyless entry system49,50,52
 - autolock51
 - locking and unlocking doors50
 - programming entry code49
- Lamps172
 - bulb replacement specifications chart179
 - headlamps173,180
 - high-mount brakelamp174
 - illuminated entry system41
 - map lamps177
 - replacing bulbs172
 - tail lamps174
- License plate lamps176
- Liftgate39
- Lights, warning and indicator .8,11
 - air bag8
 - anti-lock brakes (ABS)9
 - anti-theft10
 - brake9
 - charging system8
 - check engine10
 - check gauges8
 - door ajar8
 - fuel reset8
 - high beam9
 - overdrive off10
 - safety belt9
 - speed control9
 - turn signal indicator10
- Load limits107
- Lubricant specifications187
- Luggage rack116
- Moon roof33
- Motorcraft parts185
- Odometer7
- Overdrive26
- Overhead console28,29,30,33
 - compass/temperature display ..29
 - map lamps31,177
 - storage compartment31

Index

- Parts (see Motorcraft Parts) ...185
- Power door locks38
- Power steering
 - fluid, checking and adding148
- Rear climate control system45
- Refill capacities for fluids185
- Relays127,128
- Remote entry system
 - arming and disarming the
 - anti-theft system52,54
 - locking/unlocking doors53
 - panic alarm53
 - replacement/additional transmitters55
 - replacing the batteries54
- Repairing paint chips181
- Reporting safety defects192
- Safety chains, when towing a trailer113
- Safety defects, reporting192
- Safety restraints63
 - adjusting the safety belts67
 - automatic locking mode (retractor)66
 - center rear lap belt68
 - cleaning the safety belts71
 - extension assembly71
 - lap and shoulder belts64
 - maintenance69
 - proper use64
 - replacement70
 - warning light and chime69
- Seats
 - adjusting the seat, manual59
 - adjusting the seats, power60
 - folding rear seats62
 - head restraints62
- Servicing your vehicle136
 - precautions when servicing136,138
 - servicing when you tow115
- Shift-lock system101
- Spare tire48
- Speed control23
- Speedometer6
- Starting your vehicle89,91
 - preparing to start your vehicle89,91
 - starting a warm engine92
- Steering wheel
 - tilting27
- Tachometer6
- Tail lamps
 - bulb replacement174
- Tilt steering wheel27
- Tire types163
- Tires
 - changing128
 - checking the pressure160
 - replacing162,163
 - rotating161,162
 - snow tires and chains163
 - treadwear159
- Towing your vehicle135
- Trailer towing110,113,114
 - calculating maximum trailer weight111
 - tips115
 - trailer brakes113
 - trailer lamps114
- Transfer case
 - fluid checking152
- Trip odometer7
- Turn signal174,176
- Vehicle dimensions190
- Vehicle Identification Number (VIN)191
- Ventilating your vehicle (see Climate control)21
- Washer fluid144
 - rear window reservoir145
- Windows
 - power windows, operating35,36,37

Index

Windshield	
defrosting	21
Windshield washer fluid and	
wipers	
checking and replacing wiper	
blades	156
operation	24

Filling station information

Fuel info	Unleaded only - 87 octane
Fuel tank capacity	79.5 L (21.0 gal)
Engine oil specifications	Use only oil displaying the American Petroleum Institute Certification Mark SAE 5W-30
Tire size and pressure	See Safety Compliance Certification Label on inside of driver door
Hood release location	Bottom left of driver side instrument panel
Fuel filler location	Left rear of vehicle