

Table of contents

Introduction	2
SVT Contour Features	3
SVT Contour Towing	10
SVT Contour Service Points	11
SVT Contour Specifications	12
SVT Owner Benefits	15
SVT Contour Exterior Dimensions	16

All rights reserved. Reproduction by any means, electronic or mechanical including photocopying, recording or by any information storage and retrieval system or translation in whole or part is not permitted without written authorization from Ford Motor Company.

Copyright © 1997 Ford Motor Company

Introduction

Welcome to the Ford Special Vehicle Team family, and thank you for purchasing an SVT Contour. We trust that you will enjoy many years of safe and pleasurable driving in your new SVT Contour.

SVT strives for balance between powertrain and chassis, cornering prowess and long-distance comfort, always working to build cars in which no one system overwhelms or overshadows any other. In the SVT Contour, that philosophy is carried forward by enhancing the character and performance of the already exceptional Ford Duratec twin-cam V6 engine as well as significant interior, exterior and chassis refinements.

This supplement compliments your Contour Owner's Guide and provides information specific to the SVT Contour. By referring to the pages listed in this supplement, you can identify those features, recommendations and specifications unique to your new SVT Contour.

If you have any questions or concerns, please call us at the Ford Special Vehicle Team hotline from 8:30 a.m. to 5 p.m. EST at 1-800-FORD-SVT (1-800-367-3788).

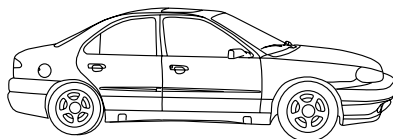

SVT Contour Features

THE SVT CONTOUR

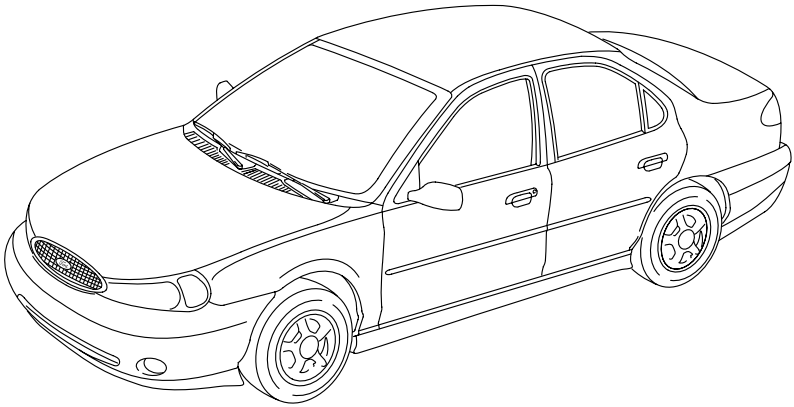

SVT Contour Features

INSTRUMENT CLUSTER

- Unique white-faced gauges
- It is recommended to dim instrument panel lighting for improved dawn/dusk legibility.

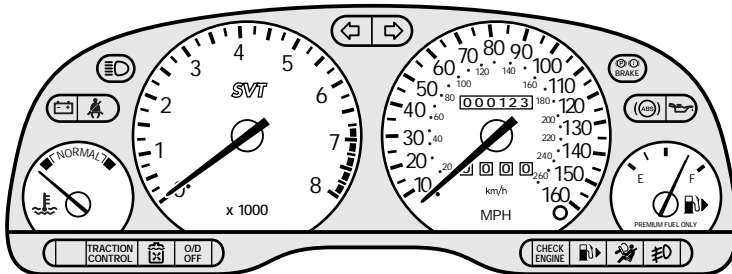

SVT Contour Features

SEATS

- Leather
- 10 way power seat
- Power lumbar support

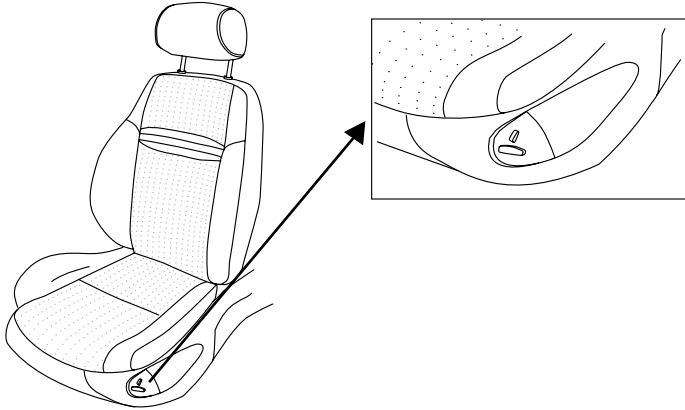

SVT Contour Features

FRONT FASCIA

- Round fog lamps
- Unique upper and lower mesh grilles
- Ducting to improve the cooling system's performance

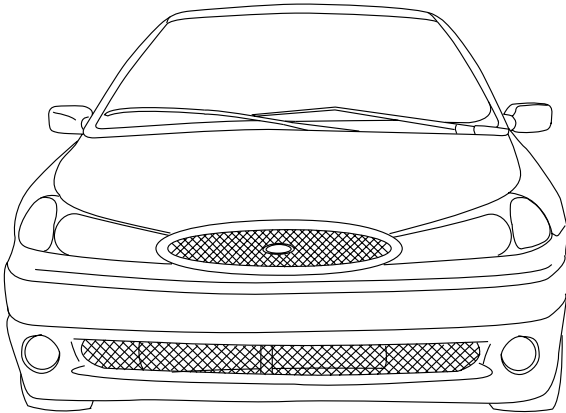

SVT Contour Features

REAR AND SIDE

- Dual exhaust: 6.4 cm (2.5 inch) exhaust tips
- Rocker sill extensions (side)
- Jacking points are notches on rocker sill. Remove highlighted covers to access jacking points.

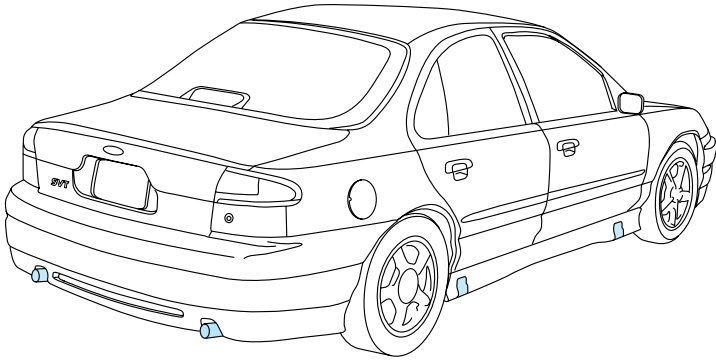

SVT Contour Features

TIRES AND WHEELS

- Tires: Goodyear Eagle F1-GS, P205/55ZR-16, unidirectional tread pattern
- Wheels: 5 spoke 16 in x 6.5 in cast aluminum
- Unique SVT center caps
- Do not use snow chains
- Recommended tire pressure: 221 kPa (32 psi)

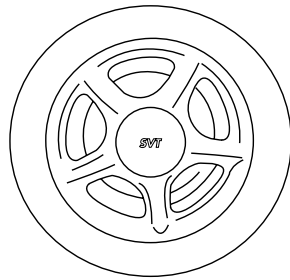

SVT Contour Features

BRAKING SYSTEM

Four channel, four sensor ABS system includes:

- Front disc: 27.79 cm (10.94 in)
- Rear disc: 25.10 cm (9.88 in)

FUEL RECOMMENDATION

91 Octane or higher

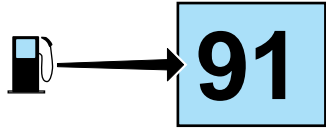

SVT Contour Towing

WRECKER TOWING

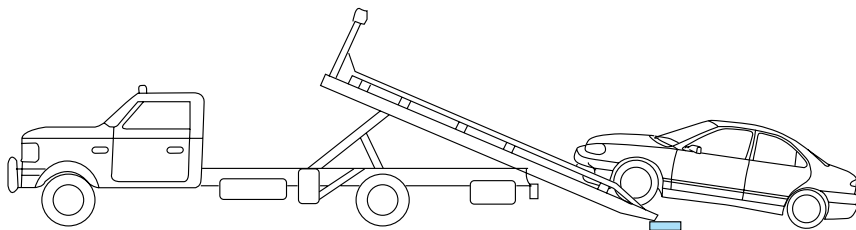

When towing your SVT Contour with a wheel lift, follow the procedure described in your Owner's Guide.

When towing your SVT Contour with flatbed equipment, you must place a block under the tongue of the inclined flatbed to decrease the angle of ascent and descent.

Failure to follow these instructions may result in damage to the vehicle's front fascia and tailpipes.

SVT Contour Service Points

ENGINE COMPARTMENT

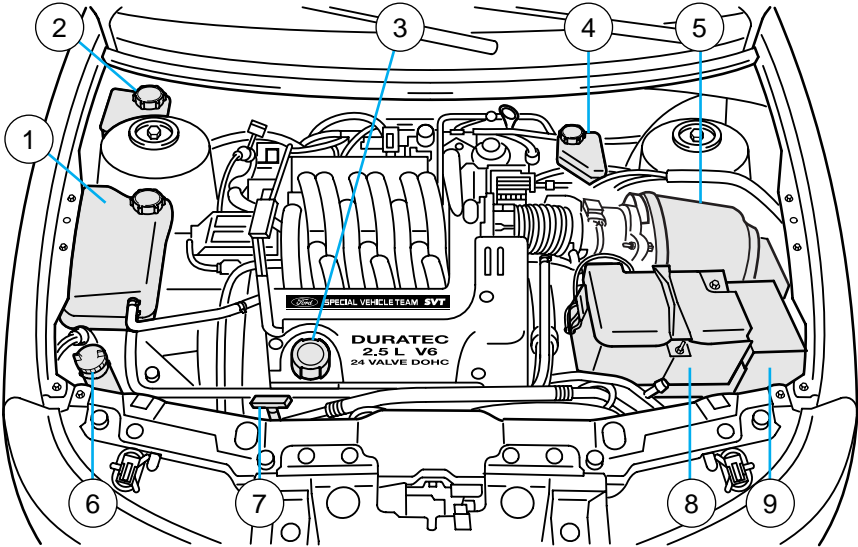

1. Engine coolant reservoir
2. Power steering reservoir
3. Engine oil filler cap
4. Brake fluid reservoir
5. Air cleaner
6. Windshield washer fluid reservoir
7. Engine oil dipstick
8. Battery
9. Fuse box

SVT Contour Specifications

ENGINE

Configuration	Transversely mounted, 60-degree V6, cast aluminum block and heads, iron cylinder liners, fully counterweighted forged crankshaft.
Bore x Stroke	3.24 in (8.23 cm) x 3.11 in (7.90 cm)
Displacement	2,544 cc / 155 cid
Compression ratio	10.0:1
Horsepower	145 kW @ 6,625 rpm (195 HP @ 6,625 rpm)
Torque	224 Nm @ 5,625 rpm (165 ft-lb @5,625 rpm)
Redline	6,750 rpm (fuel shut-off at 7,000 rpm)
Specific output	77 HP per litre
Valvetrain	Dual overhead chain-driven cams, roller finger followers with hydraulic lash adjustment, ovate-wire valve springs, four valves per cylinder.
Intake valves	2 per cylinder, 32 mm head diameter
Exhaust valves	2 per cylinder, 26 mm head diameter
Fuel system	Sequential electronic fuel injection, 19 lb/hr. injectors, 379 kPa (55 psi)
Intake manifold	Unique airflow-tuned upper intake, cast aluminum plenum chamber, extrude-hone internal surfaces
Throttle body	6.0 cm (2.36 in) bore
Air-mass sensor	7.0 cm (2.75 in) diameter
Exhaust manifolds	Steel tube (clamshell design)
Exhaust system	5.72 cm (2.25 in), stainless steel, 6.35 cm (2.5 in) polished stainless steel tips

SVT Contour Specifications

TRANSAXLE

Type: MTX-75

Final drive: 4.06:1

Gear	Ratio	Speed (mph)	Speed (km/h)
1st	3.42	35	56
2nd	2.14	56	90
3rd	1.45	82	132
4th	1.03	117	188
5th	0.77	143	230
Reverse	3.42	-	-

SUSPENSION

Front	Macpherson struts, lower A-arms, coil springs, tube shock dampers, anti-roll bar
Rear	Independent Quadralink design, coil springs, tube shock dampers, anti-roll bar

STEERING

Type	Power assist, rack and pinion
Gear ratio	14.5:1
Turns, lock to lock	2.7
Turning diameter	12.2 m (40 ft)

BRAKES

Front	27.79 cm (10.94 in) vented discs, single-position calipers
Rear	25.10 cm (9.88 in) vented discs, single-position calipers
ABS	4-channel, 4-sensor system

SVT Contour Specifications

WHEELS AND TIRES

Wheels	Cast aluminum, painted surface, five-spoke, 16 x 6.5 in
Tires	Goodyear Eagle F1-GS , P205/55ZR-16, unidirectional tread pattern

DIMENSIONS AND CAPACITIES (UNIQUE TO SVT)

Wheelbase	270.5 cm (106.5 in)
Length	467.1 cm (183.9 in)
Height	138.4 cm (54.5 in)
Width	175.5 cm (69.1 in)
Track, f/r	150.4 cm / 148.6 cm (59.2 in / 58.5 in)
Head room f/r	99.1 cm / 93.2 cm (39.0 in / 36.7 in)
Leg room, f/r	109.2 cm / 87.4 cm (43.0 in / 34.4 in)
Curb weight	1,392 kg (3 068 lbs)
Fuel tank	54.8 litres (14.5 gallons)
Weight distribution, f/r	63% / 37%

PERFORMANCE (MANUFACTURER'S SPECIFICATIONS)

0-48 km/h (0-30 mph)	2.9 seconds
0-97 km/h (0-60 mph)	7.9 seconds
0-161 km/h (0-100 mph)	21.2 seconds
Quarter mile	15.7 seconds @ 142 km/h (88 mph)
Top Speed	230 km/h (143 mph)

SVT Owner Benefits

1-800-FORD-SVT (1-800-367-3788)

This line is staffed by SVT representatives who are available from 8:30 a.m. to 5:00 p.m. (Eastern Standard Time) Monday-Friday to:

- Answer questions on your vehicle
- Provide SVT certificates of authenticity on request
- Fulfill literature requests
- Provide referrals to SVT certified Ford dealers

SVT NEWS

Owners of SVT vehicles are eligible and may elect to receive, free of charge, the official SVT newsletter, *SVT News*. The *SVT News* features articles on a variety of different topics related to SVT and our vehicles.

SVT DISCOUNT AT BOB BONDURANT DRIVING SCHOOL

Being an owner of an SVT vehicle entitles you to a 20% discount at the Bob Bondurant school of high-performance driving in Phoenix, Arizona.

SVT PERSONAL ACCESSORIES

SVT has an apparel line that you can purchase through your local SVT certified dealer or call 1-888-490-6873.

SVT Contour Exterior Dimensions

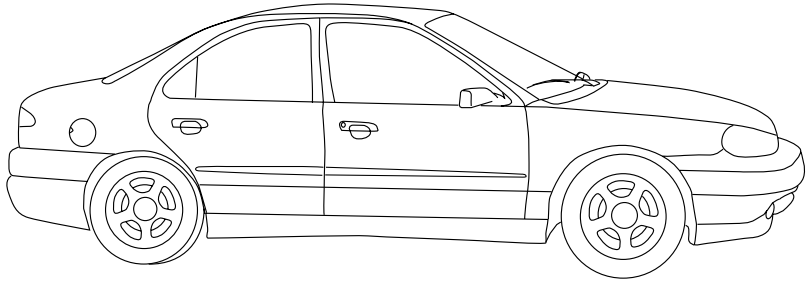

270.5 cm
106.5 in

467.1 cm
183.9 in

138.4 cm
54.5 in

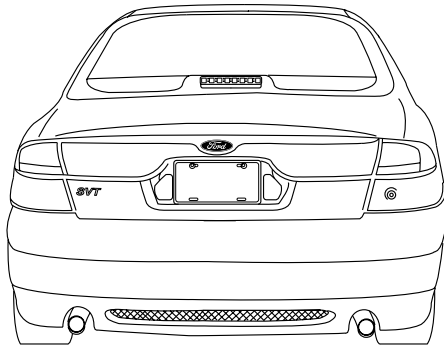

175.5 cm
69.1 in