

**WALK THE CUSTOMER THROUGH EACH OF THE FOLLOWING KEY DELIVERY FEATURES**

- **CLIMATE CONTROL** – pages 14-17
  - Explain the different air modes to customer.
- **TIRE PRESSURE MONITORING SYSTEM (TPMS)** – page 32
  - Explain TPMS function to customer.
  - When illuminated, one or more tires are under-inflated.
  - Blinks for approximately one minute then remains illuminated when there is a malfunction with the TPMS.



- **BLUE LINK** – pages 24-25
  - Assist with creating MyHyundai.com account
  - Assist with Blue Link enrollment
  - Show Blue Link Users Manual & tear out Voice Commands/Quick Tip Card
  - Encourage customers to press the Blue link button  after enrollment to initiate Welcome Call

- **CLOCK ADJUSTMENT** – page 26

**Hour 1**  
Pressing the H button will advance the time displayed by one hour.

**Minute 2**  
Pressing the M button will advance the time displayed by one minute.

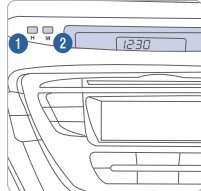

- **VEHICLE SETTINGS** – pages 12-13 & 27-29

- Demonstrate vehicle settings in instrument cluster
- Demonstrate navigation use, enter dealer address
- Show radio presets



- **BLUETOOTH** – pages 22-23
  - Demonstrate phone pairing Refer to [www.hyundaiusa.com/bluetooth](http://www.hyundaiusa.com/bluetooth)
  - Demonstrate QR code



Standard Radio



Navigation

**MAINTENANCE**

| Scheduled Maintenance   | Normal Usage  | Severe Usage*                                     |
|---|---|---|
| Engine Oil and Filter   | Replace 7,500 or 12 mos.  | Replace 3,750 or 6 mos.                           |
| Tire Rotation   | Perform 7,500   | Perform 7,500                                     |
| Air Cleaner Filter  | Inspect 7,500<br>Replace 30,000                                   | Inspect Same As Normal<br>Replace More Frequently |
| Battery Condition   | Inspect 7,500   | Inspect Same As Normal                            |
| Vacuum Hose   | Inspect 7,500   | Inspect Same As Normal                            |
| Climate Control Air Filter (For Evaporator and Blower Unit)                       | Replace 15,000  | Replace More Frequently                           |
| Air Conditioning Refrigerant  | Inspect 15,000  | Inspect Same As Normal                            |
| Brake Hoses & Lines   | Inspect 15,000  | Inspect Same As Normal                            |
| Drive Shafts & Boots  | Inspect 15,000  | Inspect 7,500 or 6 mos.                           |
| Electronic Throttle Control   | Inspect 15,000  | Inspect Same As Normal                            |
| Exhaust Pipe & Muffler  | Inspect 15,000  | Inspect Same As Normal                            |
| Front Brake Disc / Pads, Calipers   | Inspect 15,000  | Inspect More Frequently                           |
| Rear Brake Drums / Linings<br>Rear Brake Disc / Pads                              | Inspect 15,000  | Inspect More Frequently                           |
| Steering Gear Box, Linkage & Boots/<br>Lower Arm Ball Joint, Upper Arm Ball Joint | Inspect 15,000  | Inspect More Frequently                           |
| Suspension Mounting Bolts   | Inspect 15,000  | Inspect Same As Normal                            |
| Brake/Clutch Fluid  | Inspect 30,000  | Inspect Same As Normal                            |
| Fuel Filter   | Inspect 30,000  | Inspect Same As Normal                            |
| Fuel Lines, Fuel Hoses and Connections  | Inspect 30,000  | Inspect Same As Normal                            |
| Fuel Tank Air Filter  | Inspect 30,000  | Inspect Same As Normal                            |
| Parking Brake   | Inspect 30,000  | Inspect More Frequently                           |
| Vapor Hose, Fuel Tank & Fuel Filler Cap   | Inspect 30,000  | Inspect Same As Normal                            |
| Manual Transmission Fluid   | Inspect 37,500  | Replace 75,000                                    |
| Drive Belt (Alt, A/C)   | 1st Inspect 60,000 or 72 mos.<br>Add'l Inspect 15,000 or 24 mos.  | Inspect Same As Normal                            |
| Spark Plugs (Iridium Coated)  | Replace 100,000 or 10 yrs.  | Replace More Frequently                           |
| Coolant   | 1st Replace 120,000 or 10 yrs.<br>Add'l Replace 30,000 or 24 mos. | Replace Same As Normal                            |
| Automatic Transmission Fluid  | No check, No service required                                     | Replace 60,000                                    |

\*See Owner's Manual for details.

Looking for more detailed information? This Quick Reference Guide does not replace your vehicle's Owner's Manual. If you require additional information or are unsure of a specific issue, you should always refer to the vehicle's Owner's Manual or contact your authorized Hyundai dealer.

The information contained in this Quick Reference Guide was correct at the time of printing; however, specifications and equipment can change without notice. No warranty or guarantee is being extended in this Quick Reference Guide, and Hyundai reserves the right to change product specifications and equipment at any time without incurring obligations. Some vehicles are shown with optional equipment. Specifications apply to U.S. vehicles only. Please contact your Hyundai dealer for current vehicle specifications.

NP150-82014-B  
(Rev 04/21/14)  
Printing 04/24/14

HYUNDAI **ELANTRA**  
Quick Reference Guide

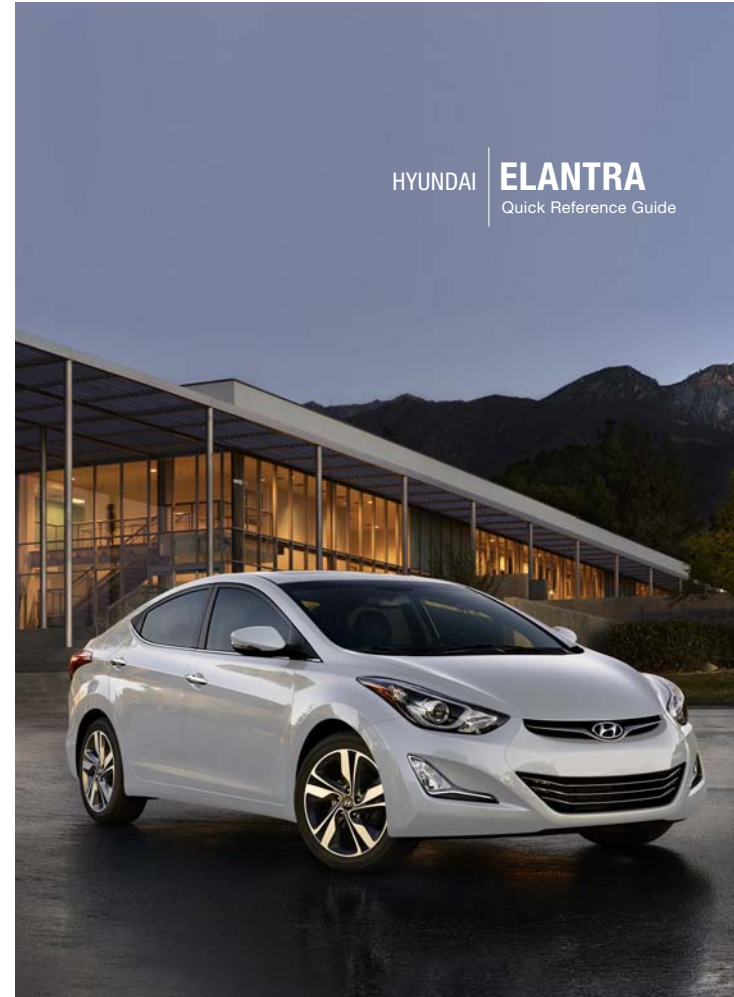

[www.hyundai.com](http://www.hyundai.com)



Roadside Assistance: **1-800-243-7766**  
 Consumer Affairs: **1-800-633-5151**  
 XM® Radio: **1-800-967-2346**  
 Blue Link: **1-855-2BLUELINK (1-855-225-8354)**

# Table of Contents

## GETTING STARTED

|                          |    |
|--------------------------|----|
| Engine start/stop button | 03 |
| Front seat adjustment    | 04 |
| Headrest adjustment      | 05 |
| Remote keyless entry     | 02 |
| Seat belt adjustment     | 05 |

## FEATURES AND CONTROLS

|  |       |
|--|-------|
| Active ECO system                      | 33    |
| Central door lock switch               | 07    |
| Child-protector rear door lock         | 34    |
| Climate control – Manual               | 14-15 |
| Climate control – Automatic            | 16-17 |
| Clock adjustment                       | 30    |
| Cruise control system                  | 18    |
| Driver Selectable Steering Mode(DSSM)  | 18    |
| Driver's main controls                 | 07    |
| Electronic Stability Control (ESC)     | 33    |
| Fuel filler lid                        | 06    |
| Head lights and fog lights             | 08    |
| Instrument cluster                     | 12-13 |
| Interior lights                        | 11    |
| Rear seat folding                      | 37    |
| Rearview camera                        | 34    |
| Seat warmer                            | 30    |
| Steering wheel adjustment              | 06    |
| Steering wheel functions               | 18-19 |
| Sunroof                                | 10    |
| Tire Mobility Kit                      | 35-36 |
| Tire Pressure Monitoring System (TPMS) | 32    |
| Trip computer                          | 13    |
| Transmission                           | 31    |
| Wiper and washer                       | 09    |

## MULTIMEDIA

|                                   |       |
|-----------------------------------|-------|
| AUX, USB and iPod® port           | 26    |
| Blue Link Telematic system        | 24-25 |
| Bluetooth® phone operational tips | 20-21 |
| Bluetooth® phone pairing          | 22-23 |
| Navigation                        | 27-29 |
| Standard radio                    | 26    |

\*Some vehicles may not be equipped with all the listed features.

## FREQUENTLY ASKED QUESTIONS

- Pair phone to your vehicle. Refer to pages 22-23.

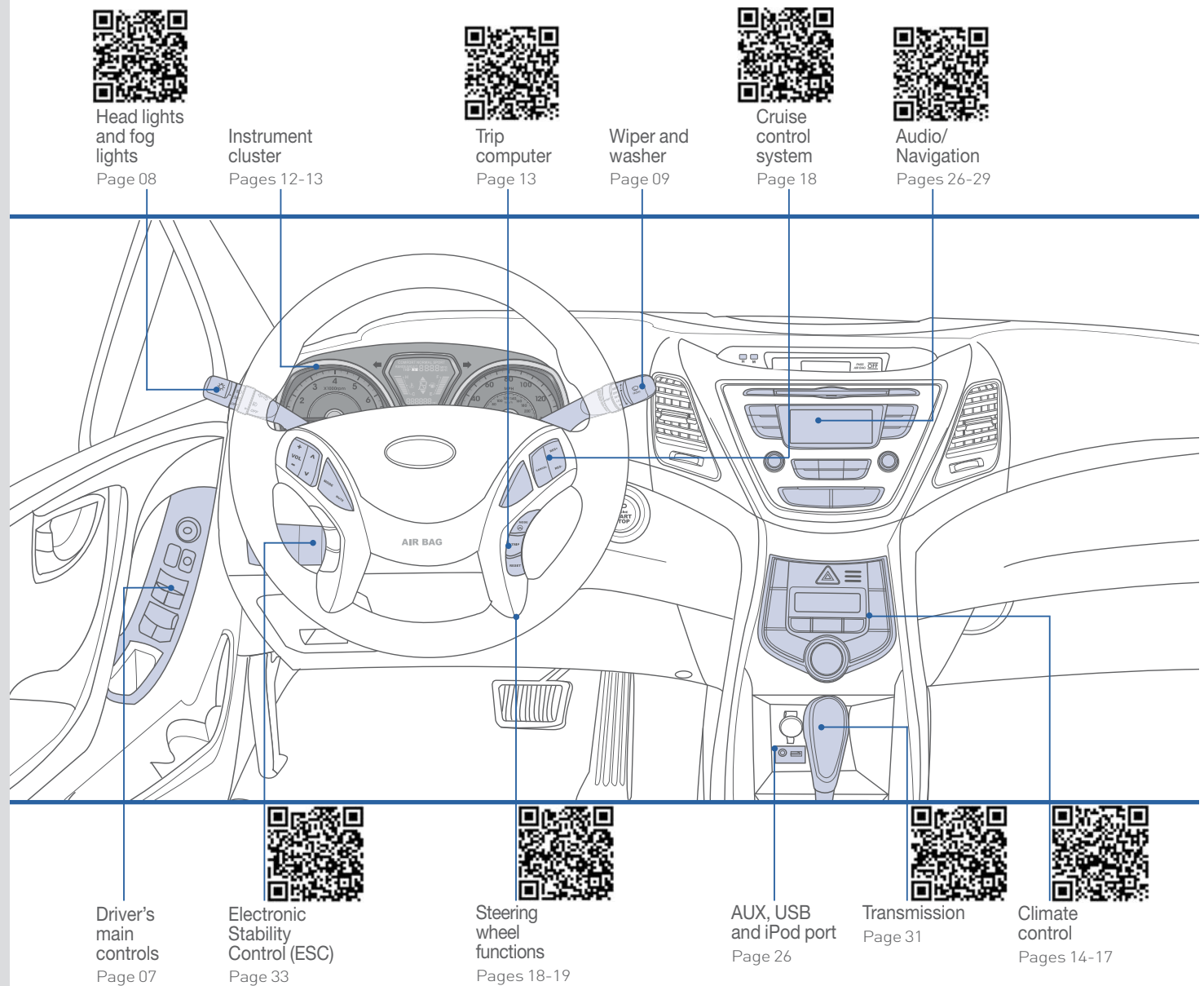

**WARNING!**

To reduce the risk of serious injury to yourself and others, read and understand the important SAFETY INFORMATION in your Owner's Manual.



## GETTING STARTED

### Download QR Code Reader

You can download a QR reader app to your smart phone to take advantage of the QR codes throughout this Quick Reference Guide.

iPhone® - Apple® App Store

Android® - Google Play

BlackBerry® - BlackBerry® App World

### REMOTE KEYLESS ENTRY

Remote Key



Smart Key



- Lock
- Unlock
- Trunk unlock
- Panic

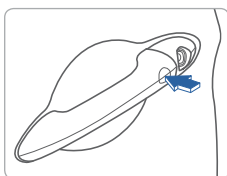

#### Driver's door Lock/Unlock

Smart key must be within range.

#### Press:

- Once – Unlock driver door
- Twice – Unlock all doors
- Third – Lock all doors

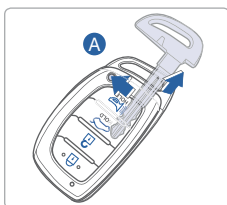

#### Remove mechanical key

Press and hold the release **A** button and remove the key.

#### Reinstall mechanical key

Put the key into the hole and push it until a click sound is heard.



### ENGINE START/STOP BUTTON

With the ignition OFF, press the engine start/stop button:

- Once for ACC (Accessory) mode.
- Twice for ON mode.
- Three times for OFF.

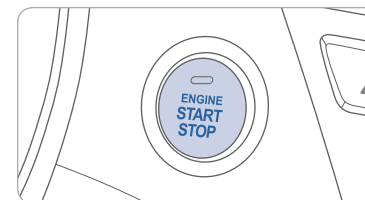

To start the engine, press the start/stop button while:

- Automatic Transmission: depressing the brake pedal.
- Manual Transmission: depressing the clutch and brake pedals.

To shut engine OFF, shift to:

- Automatic Transmission: P (Park) and press the start/stop button.
- Manual Transmission: Select 1st gear or Neutral, apply the parking brake, and press the start/stop button.

#### Emergency situations

##### Shut off engine while driving:

Press engine start/stop button for more than 2 seconds or press it 3 times consecutively within 3 seconds.

##### Restart engine while driving:

Press engine start/stop button with shift lever in N (Neutral).

### FRONT SEAT ADJUSTMENT (Manual)

Forward and backward

Seat cushion height (for driver's seat)

Seatback angle

### FRONT SEAT ADJUSTMENT (Power)

Forward and backward

Seat cushion height (for driver's seat)

Seatback angle

Lumbar support

### HEADREST ADJUSTMENT

Height adjustment

Lock knob

To raise headrest height, pull up on headrest.

To lower headrest, press lock knob while pushing down on headrest.

### SEAT BELT ADJUSTMENT (Front seat)

Pull up to raise.

Press button and push down to lower.



## FEATURES AND CONTROLS

### STEERING WHEEL ADJUSTMENT

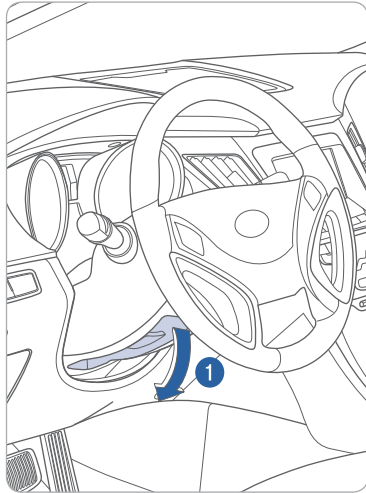

Tilt

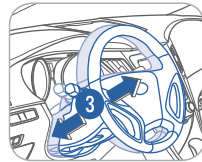

Telescopic

1. Pull the lever **1** downward.
2. Set the angle **2** and distance **3**.
3. Push the lever **1** upward. Be sure lever is locked into place before driving.

**Warning:** Never adjust steering wheel while driving. You may lose steering control and cause severe personal injury, death, or accidents.

### FUEL FILLER LID

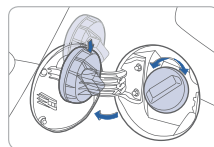
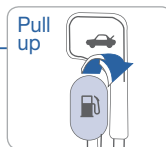
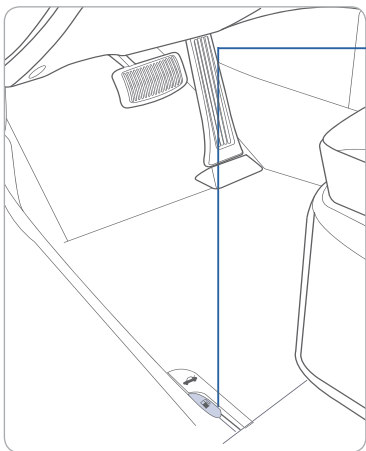

#### NOTE

After adding fuel, always reinstall the fuel cap onto the filler neck by rotating it clockwise until it clicks one time. Failure to do this may result in the Check Engine Light illuminating.



### DRIVER'S MAIN CONTROLS

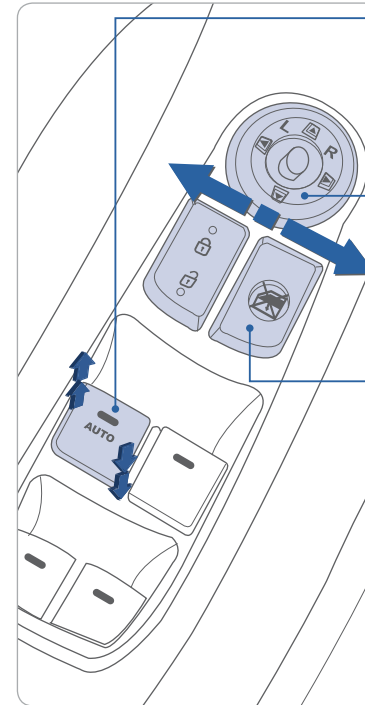

**Window Auto down/up (driver's side only)**

Press/pull past detent to fully open or close window.

**Outside Rearview Mirrors**

Move center switch to L (left) or R (right). Then adjust the mirror by pressing the directional arrows on the outer ring

**Power Window Lock Switch**

Disables the power window switches on the passenger doors.

- **Lock**  
Press the switch. (pressed in)
- **Unlock**  
Press the switch again. (pressed out)

### CENTRAL DOOR LOCK SWITCH

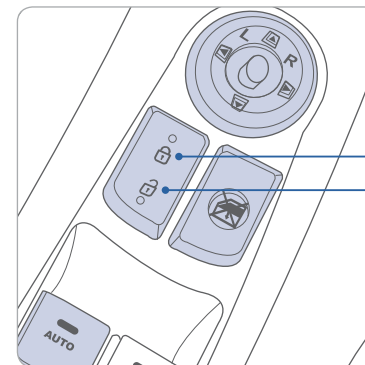

Locks all doors.

Unlocks all doors.



## FEATURES AND CONTROLS

### HEAD LIGHTS AND FOG LIGHTS

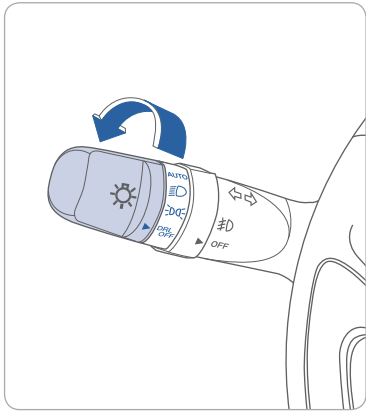

- ▶ | **AUTO** Auto light
- ▶ | Head light
- ▶ | Parking light
- ▶ | **DRL OFF** DRL OFF



#### Escort Function

Head lights may stay on for 30 seconds after exiting and locking vehicle. Press remote lock button twice to turn head lights off.

Turn signals and lane change signals

Flashing head lights

High beam Fog light

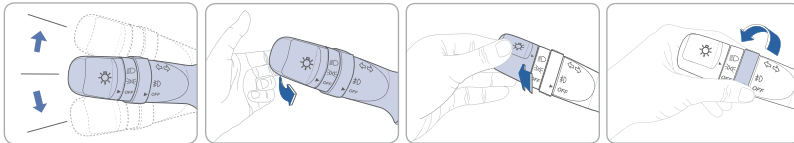

### WIPER AND WASHER

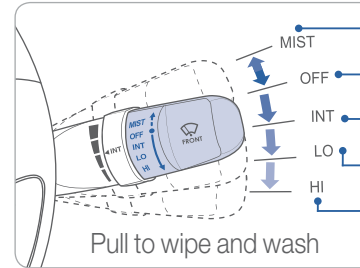

- **MIST** - Single wipe
- **OFF** - Off
- **INT** - Intermittent wipe
- **LO** - Normal wiper speed
- **HI** - Fast wiper speed

Pull to wipe and wash

#### Intermittent wipe time adjustment

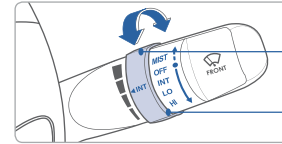

- Fast wiper speed
- Slow wiper speed



## SUNROOF

### Sliding the sunroof

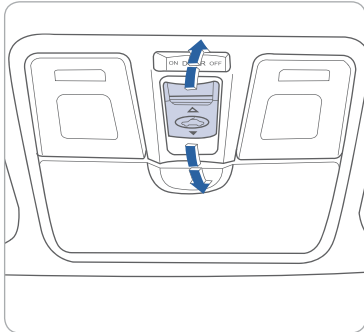

#### Open

Press switch rearward.  
Press switch rearward past the detent to open completely.

#### Close

Press switch forward.  
Press switch forward past the detent to close completely.

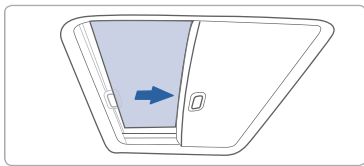

### Tilting the sunroof

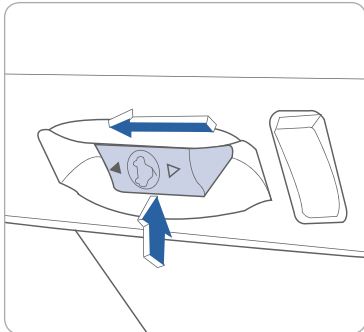

#### Tilt

Push or pull switch up or forward.

#### NOTE

Do not leave the sun shade closed while the sun roof is open.

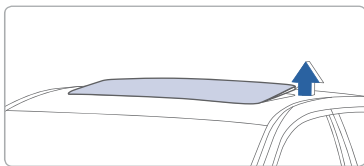

## INTERIOR LIGHTS

### Map lamp

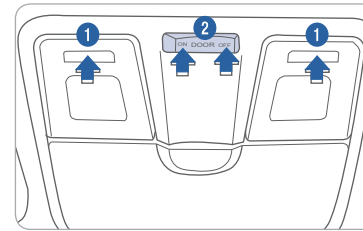

Push the lens 1 to turn the map lamp on or off.

#### Switch 2

##### ON

Map lamp and room lamp will turn on.

##### DOOR

Map lamp and room lamp will turn on when any door is open except trunk.

##### OFF

The lights stay off at all times, except when individually turned on.

#### Switch 3

##### ON

Room lamp will turn on or off.

### Rear Room Lamp

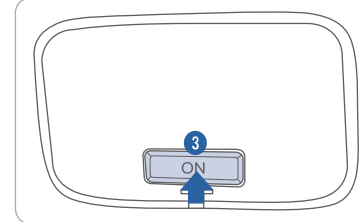



## FEATURES AND CONTROLS

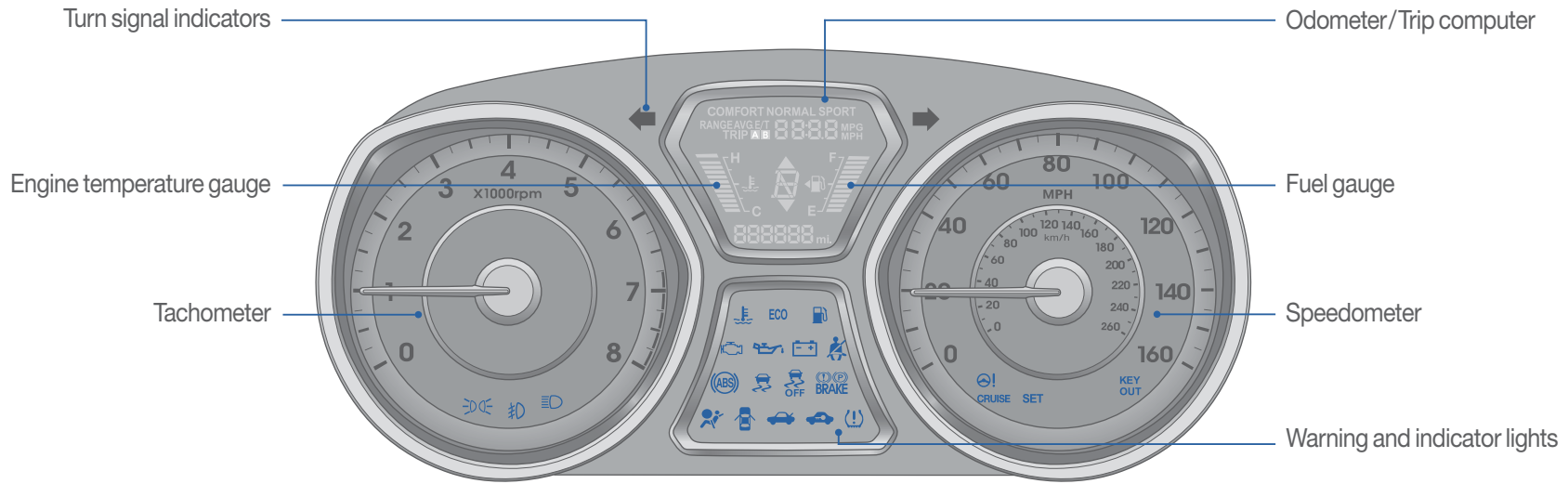

### WARNINGS AND INDICATORS

|   |  |  |
|---|--|--|
| Air bag warning light                                   | Parking brake & Brake fluid warning light  | ABS warning light                            |
| Seat belt warning light                                 | Low Tire Pressure Indicator / TPMS (Tire Pressure Monitoring System) malfunction indicator |  |
| High beam indicator                                     | Engine oil pressure warning light  | Charging system warning light                |
| <b>EPS</b> Electric Power Steering system warning light | Door open warning light  | Turn signal indicator                        |
| Immobilizer indicator                                   | Automatic transmission shift indicator   | Manual transmission shift indicator          |
| Trunk open warning light                                | Low fuel level warning light   | ESC (Electronic Stability Control) indicator |
| ESC (Electronic Stability Control) OFF indicator        | <b>CRUISE</b> Cruise indicator   | <b>SET</b> Cruise SET indicator              |
| Malfunction indicator light                             | Front fog light indicator  | <b>ECO</b> ECO indicator                     |
| Light on indicator                                      | Engine coolant temperature warning light   | DSSM (Driver Selectable Steering Mode)       |

### INSTRUMENT PANEL ILLUMINATION

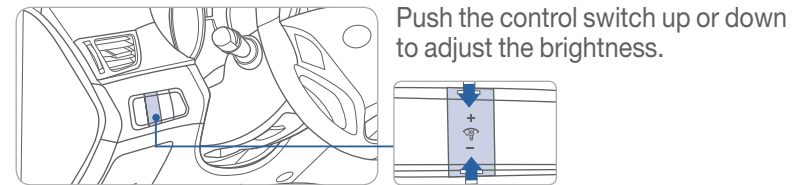

### TRIP COMPUTER

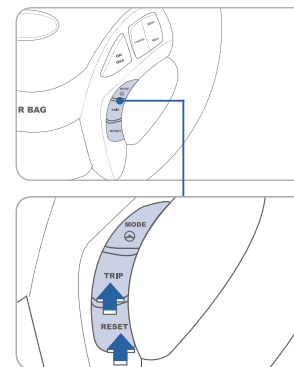

Press the TRIP button to select function as follows:

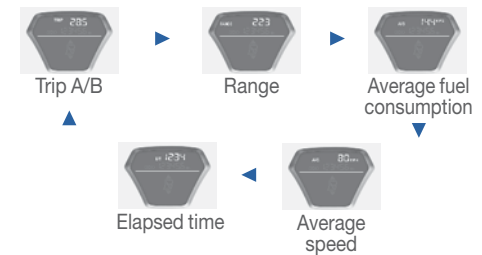



## FEATURES AND CONTROLS

### Manual Climate Control

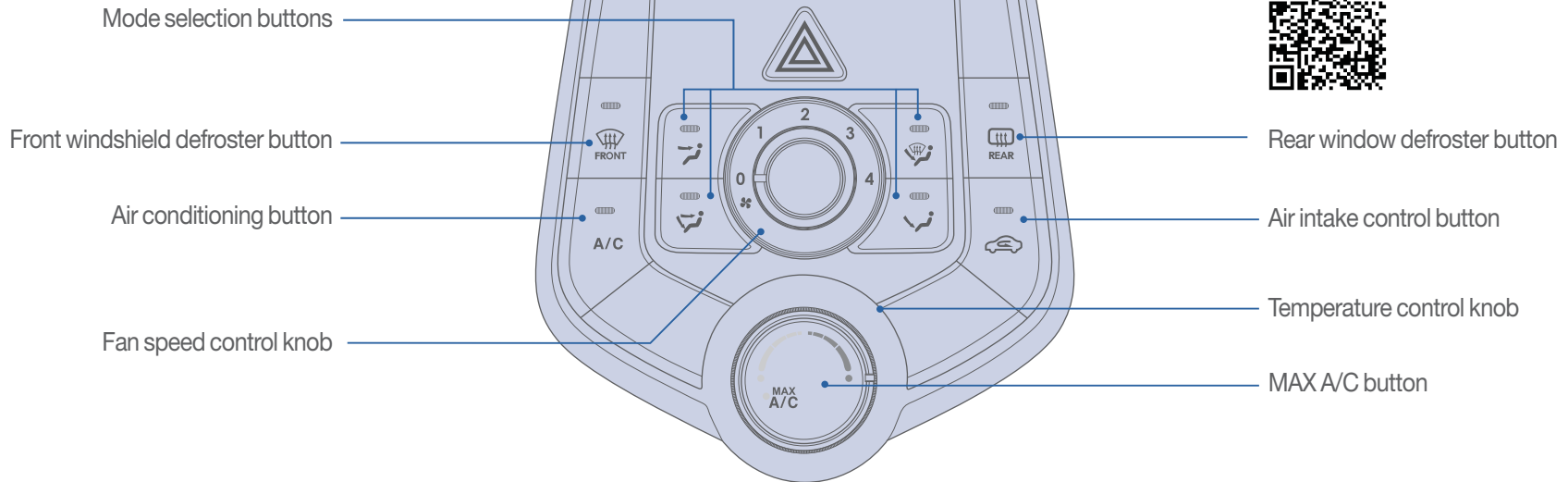

### DEFROSTING / DEFOGGING



1. Press the front windshield defrost control.



2. Set the temperature control to the warmest setting.



3. Set the fan speed to the highest setting.

#### NOTE

To reduce tendency of the glass fogging and also to improve visibility, keep the interior surface of the windshield clean by wiping it with a clean cloth and glass cleaner.

### AIR INTAKE CONTROL

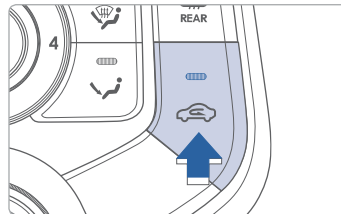

Outside (fresh) air position



Recirculated air position (LED on)

### MODE SELECTION



Face Level



Bi-Level



Floor Level



Floor & Defrost Level



Defrost Level

### REAR WINDOW DEFROSTER

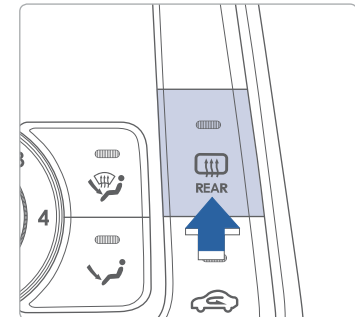

Press to activate/deactivate the rear window defroster.

## FEATURES AND CONTROLS

### Automatic Climate Control

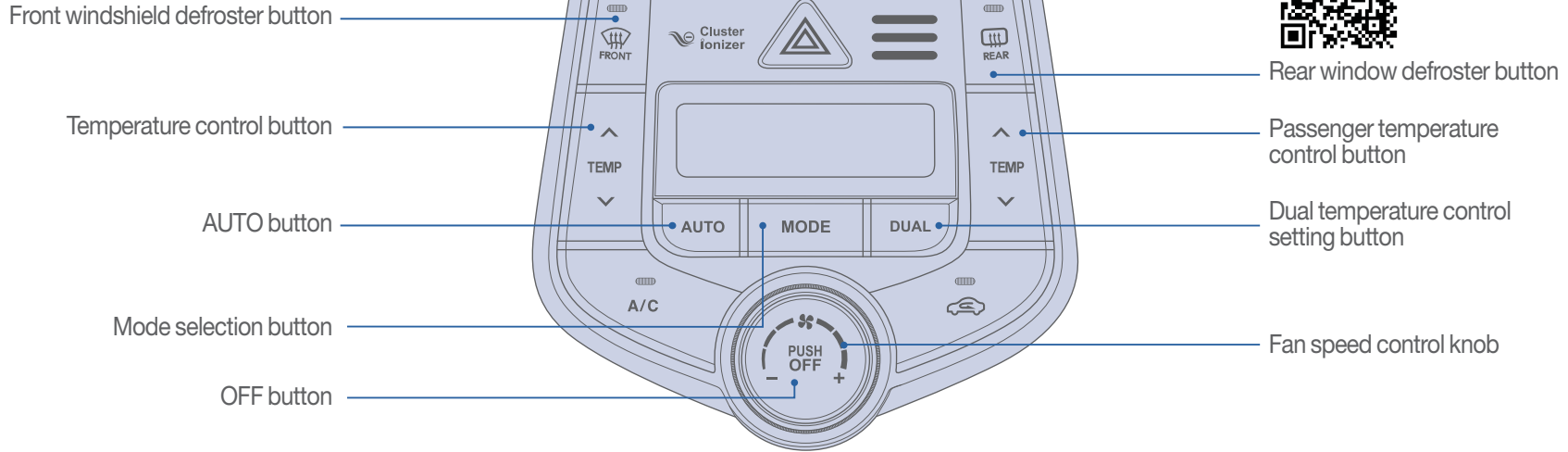

### DEFROSTING / DEFOGGING



1. Press the front windshield defrost control.



2. Set the temperature control to the warmest setting.



3. Set the fan speed to the highest setting.

#### NOTE

To reduce tendency of the glass fogging and also to improve visibility, keep the interior surface of the windshield clean by wiping it with a clean cloth and glass cleaner.

### AIR INTAKE CONTROL

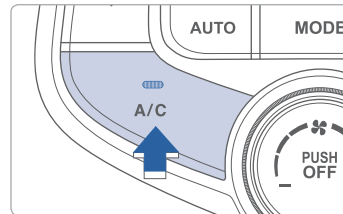

Outside (fresh) air position



Recirculated air position (LED on)

### MODE SELECTION



Face Level



Bi-Level



Floor Level



Floor & Defrost Level



Defrost Level

### REAR WINDOW DEFROSTER



Press to activate/deactivate the rear window defroster.

### AUTOMATIC HEATING AND COOLING

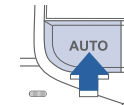

1. Press AUTO button.



2. Set the temperature control to the desired setting.

Mode selection, fan speeds, air intake, and air conditioning will be controlled automatically according to the temperature setting.



## FEATURES AND CONTROLS

### STEERING WHEEL FUNCTIONS

#### Cruise Control

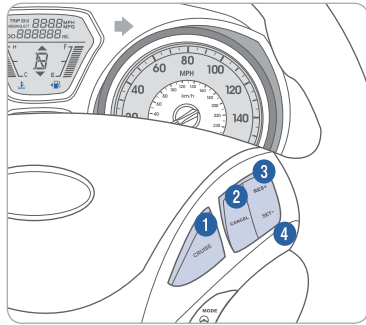

**CRUISE** Cruise indicator

**SET** Cruise set indicator



#### To set a cruising speed

1. Press CRUISE button ① and the CRUISE indicator will illuminate in the instrument cluster. Accelerate to desired cruising speed (above 25 mph).
2. Press SET - button ④ and remove your foot from the accelerator pedal.

#### To accelerate or decelerate

Press RES + button ③ up to increase set cruising speed.  
Press SET - button ④ down to decrease set cruising speed.

#### To cancel cruising speed

Press CANCEL button ②, depress brake pedal, or press CRUISE button ①.

#### Driver selectable steering mode

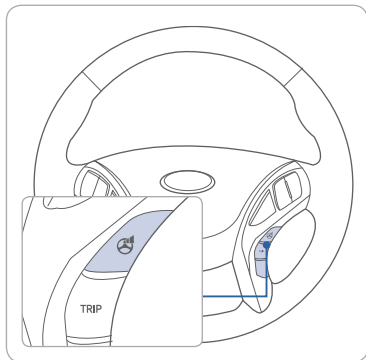

The Driver Selectable steering mode controls steering effort as driver's preference or road condition.

Pushing the button once tells you what the current mode is. Pressing the button again will scroll through the different modes.

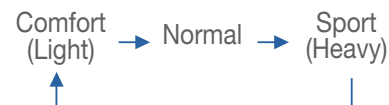

## MULTIMEDIA

#### Audio Control

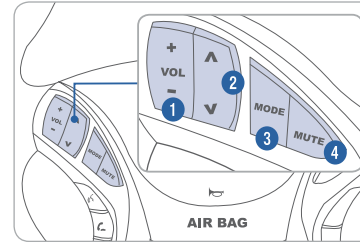

- ① **Volume**  
Raises or lowers speaker volume.
- ② **Seek/Preset**  
Change station.
- ③ **Mode**  
Change the audio source.
- ④ **Mute**  
Mute the sound.

Please refer to your Owner's Manual for more detailed information on how to use your audio system. Complimentary XM® subscription ends three months following the vehicle date of sale. Please contact XM® Radio at 1-800-XM-RADIO (1-800-967-2346) to renew your XM® subscription.

#### Bluetooth Control

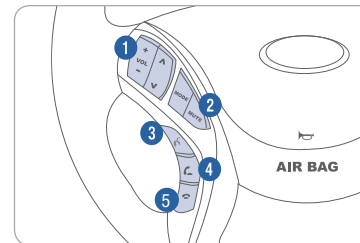

- ① **Volume**  
Raises or lowers speaker volume.
- ② **Mute**  
Mute the microphone during a call.
- ③ **Talk**  
Activates voice recognition.
- ④ **Call**  
Places and transfers calls.
- ⑤ **End**  
Ends calls or cancels functions.

To redial previously dialed number, press and hold ③.

\*Bluetooth is a wireless technology that allows multiple devices to be connected in a short range, low powered devices like hands-free, stereo headset, wireless remocom, etc. For more information, visit the website at [www.bluetooth.com](http://www.bluetooth.com)



## MULTIMEDIA

### BLUETOOTH OPERATIONAL TIPS

In the following situations you or the other party may have difficulty hearing each other:

1. High level volume may result in distortion and echo. Keep the Bluetooth volume to a low level.
2. When driving on a rough road, high speeds and/or with the window open.
3. When the air conditioning vents are facing the microphone and/or when the air conditioning fan is at the max speed.

#### Steering wheel bluetooth control

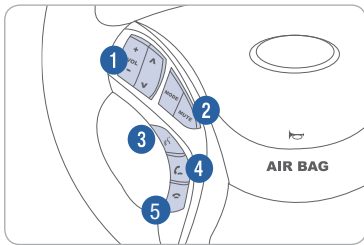

- 1 Volume**  
Raises or lowers speaker volume.
- 2 Mute**  
Mute the microphone during a call.
- 3 Talk**  
Activates voice recognition.
- 4 Call**  
Places and transfers calls.
- 5 End**  
Ends calls or cancels functions.

To redial previously dialed number, press and hold **4**.

\*Bluetooth is a wireless technology that allows multiple devices to be connected in a short range, low powered devices like hands-free, stereo headset, wireless remocom, etc. For more information, visit the website at [www.bluetooth.com](http://www.bluetooth.com)



### Voice Recognition Tips

Your vehicle is equipped with Voice Recognition technology which allows drivers to operate their phones without having to take their eyes off the road to minimize distractions.

Voice recognition performance may be affected if driving with windows and sun roof open; when the heating-cooling system is on; when passing a tunnel or when driving on rugged and uneven roads.

For complete list of commands, refer to your Owner's Manual.



## MULTIMEDIA

### BLUETOOTH PHONE PAIRING

Pairing tutorials, phone compatibility and Operational tips can be found through the Smart QR code using the QR reader application on your Smartphone.



### Phone setup (pairing phone) with Audio

#### Type A

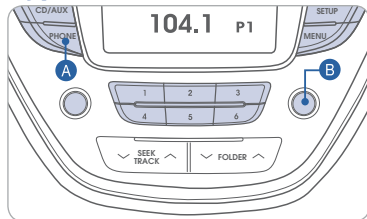

#### Type B

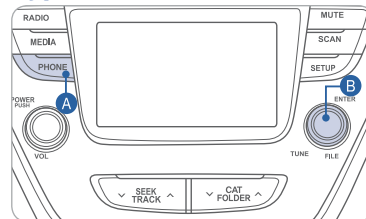

1. Push the PHONE button **A**.
2. Select "Phone" by rotating TUNE knob **B**, then press knob to select.
3. Select "Pair" by rotating the TUNE knob **B**, then press knob to select.
4. Enable Bluetooth® on your phone.
5. Select "ELANTRA" on your mobile phone from the Bluetooth® list.
6. Input passkey displayed on the screen when applicable.
7. If your phone prompts a phonebook access request, it is advisable to check the box "Always allow" or "Don't ask again".

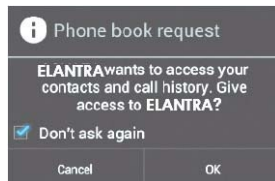

### Phone setup (pairing phone) with Navigation

1. Press the call button **1**.
4. Enable Bluetooth on your phone. Input the passkey displayed on the screen when applicable. (The initial passkey is 0000.)

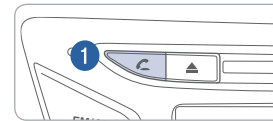

2. Press "YES" on the PHONE screen. Then press "Connections".

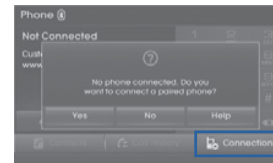

3. Press the **2** "Add New" to pair a new mobile phone.

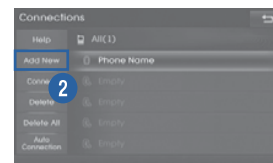

5. If your phone prompts a phonebook access request, it is advisable to check the box "Always allow" or "Don't ask again".

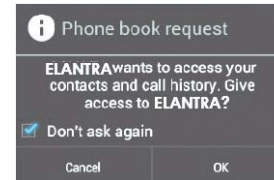

#### NOTE

Vehicle must be in Park to complete pairing process.



## MULTIMEDIA

### BLUE LINK TELEMATIC SYSTEM

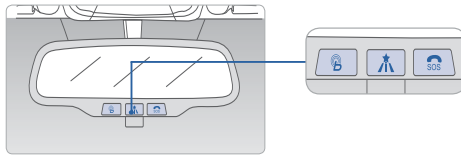

- Press the **B** button for access to the voice-response menu of services. You have two options:
- You can say, "Main Menu" for a listing of main menu choices.
  - You can directly select any of the listed menu items by saying its name.

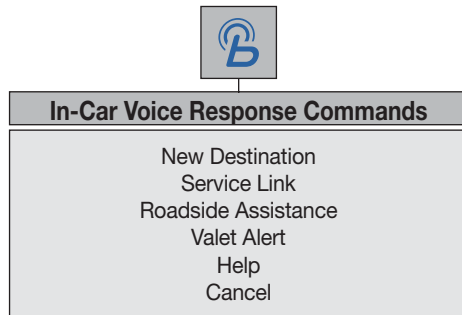

- Press the button for navigation-related services.
- Press the button for SOS Emergency Assistance.
- Refer to your Blue Link User's Manual for detailed information on system operation.
- For immediate assistance with subscription services, please call 1-855-2BLUELINK (1-855-225-8354).
- Please register your Blue Link at [www.myhyundai.com](http://www.myhyundai.com).

Blue Link feature availability is dependent upon your Blue Link subscription package(s).



### Remote Door Unlock/Lock

#### Blue Link Mobile App



You can download the Blue Link mobile app to your compatible smart phone from the following sites:

- iPhone® — Apple® App Store
- Android® — Google Play

With this feature, you can lock or unlock your vehicle doors from virtually anywhere by using the Blue Link mobile phone app, by dialing the toll-free number, or by using the Blue Link owner's website.

- To use this feature, you must have a Blue Link Personal Identification Number (PIN). To create or change your PIN, log on to [www.MyHyundai.com](http://www.MyHyundai.com).

#### To Activate Remote Door Unlock/Lock

- By Blue Link Mobile App: Select DOOR UNLOCK or DOOR LOCK, as desired.
  - Enter your Blue Link PIN.
  - The command to lock or unlock your doors will be sent to your vehicle.
- By phone: Dial toll-free 1-855-2-BLUELINK (1-855-225-8354).
- By web site: Log on to [www.MyHyundai.com](http://www.MyHyundai.com), select Blue Link.
  - Select Remote Services, then Remote Door Unlock/Lock.
  - Input your Blue Link PIN. (If you need time to get to your vehicle, specify a time delay before your vehicle will be unlocked.)



## MULTIMEDIA

### STANDARD RADIO

#### Type A

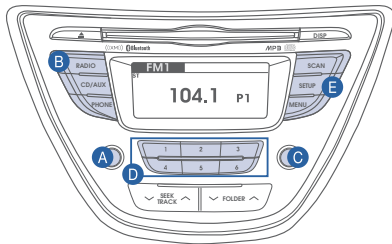

#### Type B

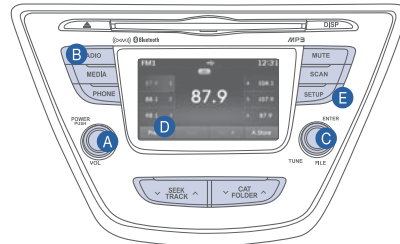

Press POWER button **A** to turn radio on.

#### • TUNING/LISTENING TO CHANNELS

1. Press Radio **B**.
2. Rotate TUNE knob **C** to desired channel.

**NOTE** A clear view of the southern sky helps to ensure XM<sup>®</sup> radio reception.

#### • SETTING PRESET MEMORY BUTTONS (FM/AM/XM<sup>®</sup>)

1. Press and hold any preset button (1-6) **D** until audible beep is heard to store current channel.

#### • ADJUSTING THE SOUND CONTROL

1. Press SETUP **E**.
2. Select “Audio” by rotating TUNE knob **C**, then press knob to select.
3. Select “Bass / Mid / Tre / Fad / Bal” by rotating TUNE knob **C**, then press knob to select.
4. Rotate TUNE knob **C** to adjust, then press knob to select.
5. Press SETUP **E** when done.

Please refer to your Owner’s Manual for more detailed information on how to use your audio system. Complimentary XM<sup>®</sup> subscription ends three months following the vehicle date of sale. Please contact XM<sup>®</sup> Radio at 1-800-XM-RADIO (1-800-967-2346) to renew your XM<sup>®</sup> subscription.

### AUX, USB AND iPod<sup>®</sup> PORT

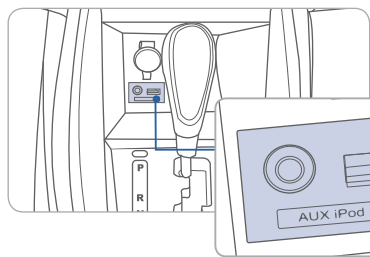

Use the jack to connect an external audio device and listen to it through the audio system speakers in your vehicle.

**NOTE:** To operate your iPod<sup>®</sup> through the vehicle’s audio system, connect your Apple supplied USB cable to the USB port  
iPod<sup>®</sup> is a trademark of Apple Inc.



### NAVIGATION

#### Audio mode

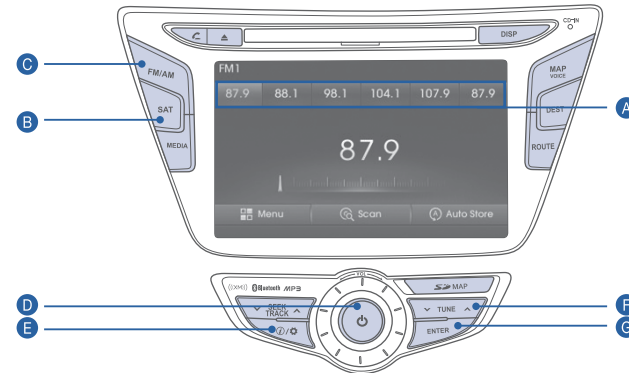

Press POWER button **D** to turn radio on.

#### • TUNING/LISTENING TO CHANNELS

1. Press FM/AM **C** or SAT **B**.
2. Press TUNE button **F** to desired channel.

**NOTE** A clear view of the southern sky helps to ensure XM<sup>®</sup> radio reception.

#### • SETTING PRESET MEMORY BUTTONS (FM/AM/XM<sup>®</sup>)

Press and hold any preset button (1-6) **A** on the screen until audible beep is heard to store current channel.

#### • ADJUSTING THE SOUND CONTROL

1. Press **E** to enter SETUP menu.
2. Press button.
3. Press on-screen arrows to adjust desired setting.



#### • SELECTING TRACK THROUGH SEARCH (CD/USB MODE)

1. Press the TUNE button **F** to search for desired display track.
2. Press the ENTER button **G** to select the desired track.



## MULTIMEDIA



## NAVIGATION

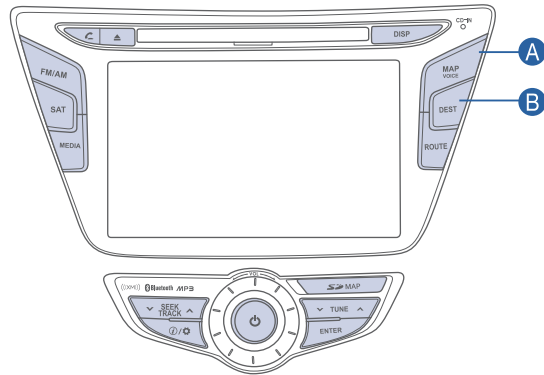

### Map position



Current vehicle position icon



Press MAP button **A** to display map position.

Refer to Digital Navigation System User's Manual for more details.

### Destination menu

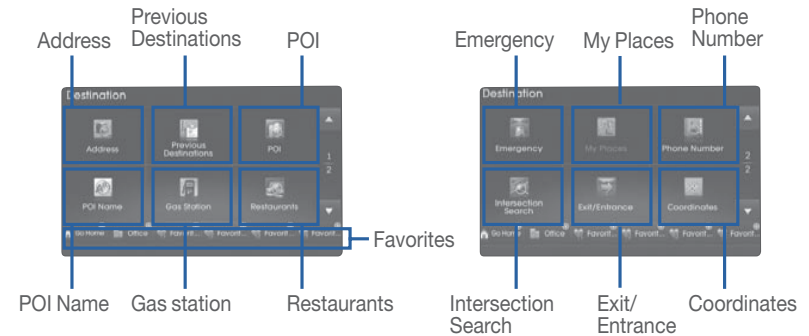

Press DEST button **B** to display destination menu.

- Previous Destinations: Search and select previous destinations.
- Address: Search destinations by selecting specific states/cities/roads.
- POI name: Search for POIs by name.
- Favorites: Store favorite places.
- POI (Point of Interest): Search for neighboring POIs near current position, scroll position, destination and city center.
- Gas Station: Search for gas station.
- Restaurants: Search for restaurants.
- Emergency: Search for emergency related facilities.
- My Places: List of saved My Places.
- Intersection Search: Search destinations by selecting street intersections.
- Phone Number: Search destinations by entering POI phone number
- Exit/Entrance: Search destinations by searching for expressway exits and entrances
- Coordinates: Search destinations by entering the latitude and longitude coordinates.





## FEATURES AND CONTROLS

### SEAT WARMER

#### Front seat

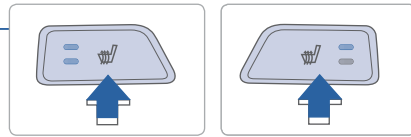
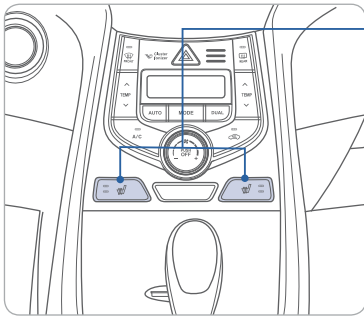

Push desired button to warm the seat.

OFF → HIGH ( ) → LOW ( )



#### Rear seat

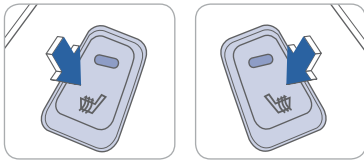

Push the button to warm the seat.  
Push button again to turn off.

### CLOCK ADJUSTMENT

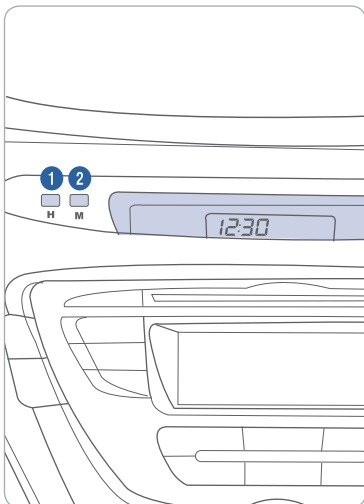

**Hour 1**  
Pressing the H button will advance the time displayed by one hour.

**Minute 2**  
Pressing the M button will advance the time displayed by one minute.

Press the H and M buttons at the same time for more than 5 seconds to toggle between 12- and 24-hour formats.



### AUTOMATIC TRANSMISSION

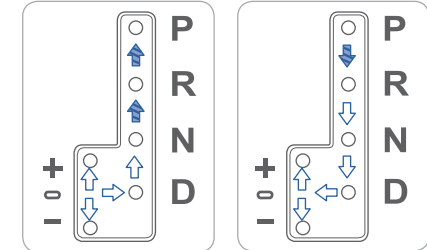
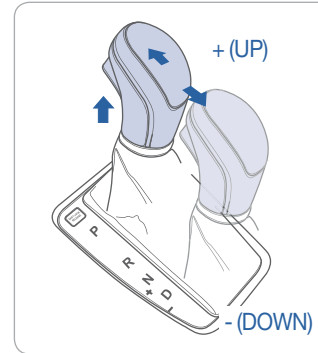

( ) : Depress the brake pedal when shifting.

( ) : The shift lever can be moved freely.

( ) : Depress the brake pedal and press the lock out button to shift.

#### Sport mode

Move the shift lever from D to the right gate to select.  
Move the shift lever forward (+) to upshift or rearward (-) to downshift.

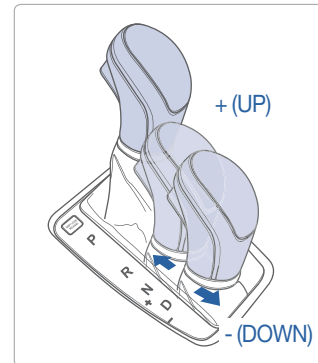

### MANUAL TRANSMISSION

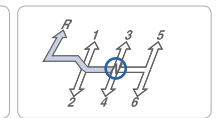
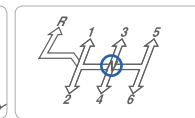

#### Shifting into Reverse

1. Depress the clutch pedal fully.
2. Ensure shifter is in Neutral.
3. Press the reverse lock-out button and move the shift lever left into Reverse.
4. Release clutch slowly for smooth acceleration.

## TIRE PRESSURE MONITORING SYSTEM (TPMS)

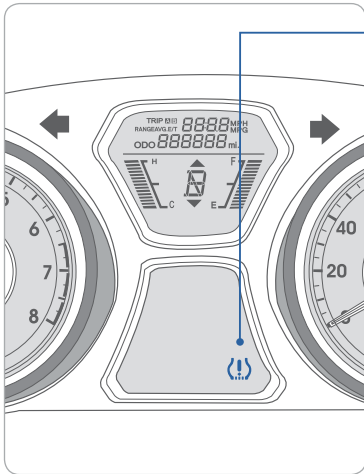

Low Tire Pressure Indicator /  
TPMS Malfunction Indicator



### Low Tire Pressure Indicator

Illuminates if one or more of your tires is significantly under-inflated.

### TPMS Malfunction Indicator

Blinks for approximately one minute then remains illuminated when there is a malfunction with the TPMS system. Have the system checked by an authorized Hyundai dealer.

### NOTE

Tire pressure may vary in colder temperatures causing the low tire pressure light (!) to illuminate.

## ELECTRONIC STABILITY CONTROL (ESC)

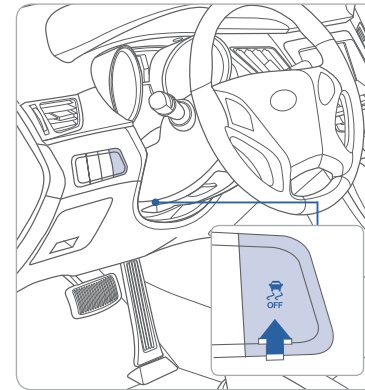

The ESC system is an electronic system designed to help the driver maintain vehicle control under adverse conditions.

- To turn the ESC off, press the button. Indicator will illuminate on the instrument cluster.
- To turn ESC on, press it again.
- System defaults to ON position at start.



## ACTIVE ECO SYSTEM

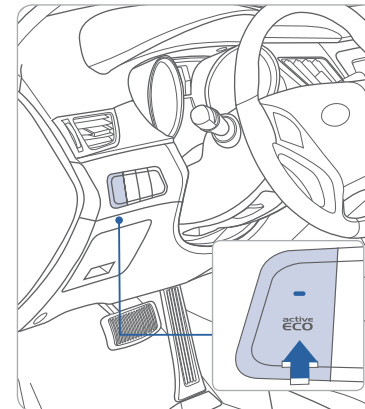

### Active ECO system (automatic transmission)

Active ECO system helps to improve fuel efficiency. When the Active ECO system is activated, the vehicle acceleration, gear shift points and air conditioning performance will be reduced to conserve the fuel consumption.

Press the Active ECO button to activate. The LED on the button and the ECO indicator in the instrument cluster will illuminate.

### ECO Shift (Manual Transmission)

▲ or ▼ symbol is displayed along with the current gear position, which informs you to up shift or down shift to the next recommended gear position for fuel efficiency.



### To improve your fuel efficiency:

- Drive smoothly and accelerate at a moderate rate.
- Avoid heavy accelerations.
- Maintain steady cruising speed.
- Adjust the vehicle speed to the traffic condition and avoid speed changes.
- Avoid unnecessary braking.
- Keep the tires inflated to the recommended tire pressure.
- Don't idle the engine longer than necessary.



## FEATURES AND CONTROLS

### REARVIEW CAMERA

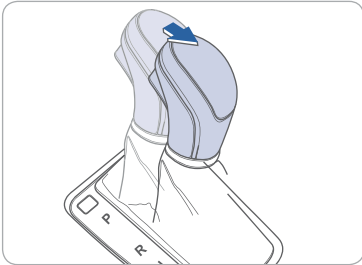

The rearview camera will activate when the ignition switch is turned ON and the shift lever is in the R (Reverse) position.

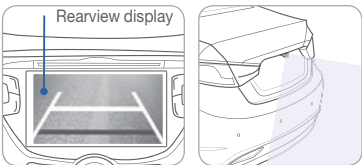

### CHILD-PROTECTOR REAR DOOR LOCK

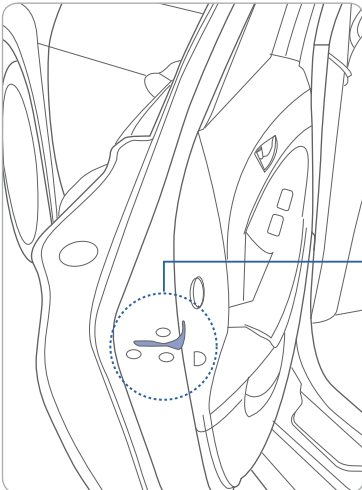

Insert a key into the hole and turn it to the following positions:



**Lock (🔒)**  
Only allows opening the rear door handle from outside of the vehicle.

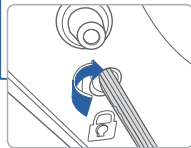

**Unlock (➡)**  
Allows opening the rear door handle from inside and outside the vehicle.



### TIRE MOBILITY KIT

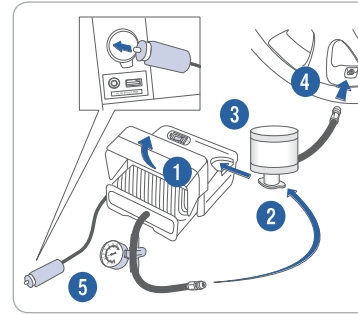

#### Setup

1. Remove the speed restriction label from the sealant bottle and place it on the center of the steering wheel.
2. Ensure that the compressor is switched to OFF.
3. Lift the cable cover 1 and screw the compressor hose 2 on to the connector of the sealant bottle.
4. Insert the sealant bottle into the housing slot 3 of the compressor.
5. Screw the filling hose 4 of the sealant bottle onto the tire's valve stem.
6. Insert the compressor power plug 5 into the vehicle's power outlet.
7. Turn the ignition switch to the ON position or press the Engine Start/Stop button twice.

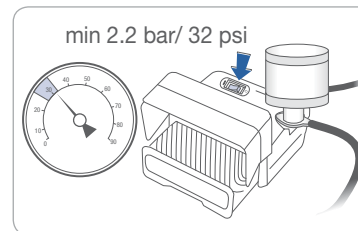
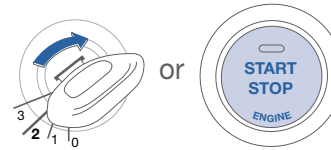

#### Inflate Tire

1. Switch ON the compressor and let it run for approximately 5 minutes.
2. Switch OFF the compressor and check to ensure that inflation pressure is over 32 psi. If not, the puncture is too large to repair. Contact Hyundai Roadside Assistance.
3. Remove the filling hose 4, compressor hose 2, and compressor power plug 5.

continued on next page...



## FEATURES AND CONTROLS

### TIRE MOBILITY KIT (CONT)

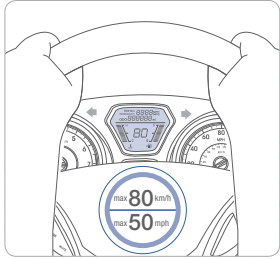

#### Drive Vehicle

1. Drive for approximately 6 miles or 10 minutes no faster than 50 mph.

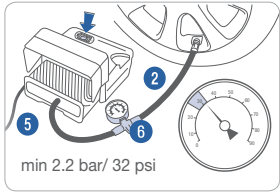

#### Recheck Tire Pressure

1. Screw the compressor hose **2** directly to the tire valve.
2. Insert the compressor power plug **5** into the vehicle's power outlet.
3. Adjust to the recommended tire pressure located on the driver side door jam placard.

#### To increase the tire pressure:

1. Switch ON the compressor.
2. To check the current tire pressure, briefly switch OFF the compressor.

#### To reduce the tire pressure:

1. Loosen the knob **6** on the gauge. Tighten the knob **6** to set tire pressure.



### REAR SEAT FOLDING

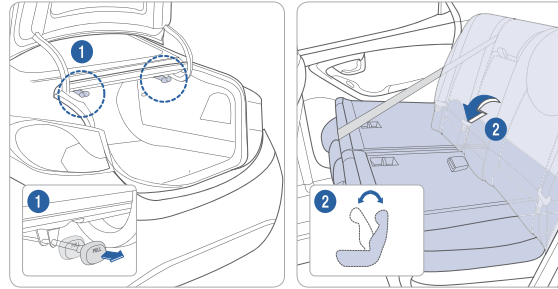

### KEY WEBSITES

Hyundai website - [www.hyundai.com](http://www.hyundai.com)  
 Hyundai owner website - [www.myhyundai.com](http://www.myhyundai.com)  
 Bluetooth phone compatibility - [www.hyundaiusa.com/bluetooth](http://www.hyundaiusa.com/bluetooth)

## ELANTRA CUSTOMER DELIVERY CHECKLIST

|                  |                  |
|------------------|------------------|
| HYUNDAI OWNER    | DEALERSHIP NAME  |
| SALES CONSULTANT | DATE             |
| VIN              | PREVIOUS VEHICLE |

### BEFORE DELIVERY

- CONFIRM "GOOD BATTERY" USING GR8 AND STAPLE TEST TICKET HERE
- SET TIRE PRESSURE LF \_\_\_ RF \_\_\_ RR \_\_\_ LR \_\_\_
- VERIFY VEHICLE IS CLEAN, IN GOOD CONDITION, FREE OF CHIPS AND SCRATCHES · CLEAN WINDSHIELD AND BACK WINDOW
- ENSURE FLOORMATS ARE SNAPPED INTO PLACE

Sales Consultant \_\_\_\_\_ Date \_\_\_\_\_ Sales Manager \_\_\_\_\_ Date \_\_\_\_\_  
 Customer \_\_\_\_\_ Date \_\_\_\_\_  
 Email \_\_\_\_\_ @ \_\_\_\_\_