



**CHECKER MOTORS  
CORPORATION**

**AUTOMATIC TRANSMISSION  
MANUAL**

# GENERAL INDEX

|   | <u>PAGE NO.</u> |
|---|-----------------|
| <u>DRIVING INSTRUCTIONS</u>   |                 |
| "D"-DRIVE RANGE - "L"-LOW RANGE - "R"-REVERSE -<br>DOWNSHIFT - TOWING CAR.....                                | 1               |
| <u>MAINTENANCE</u>  |                 |
| CHECKING FLUID LEVEL - CHANGE FLUID - FRONT BAND ADJUSTMENT.....  | 2               |
| FRONT BAND ADJUSTMENT.....  | 2               |
| REAR BAND ADJUSTMENT.....   | 5               |
| <u>PLANETARY GEAR TRAIN</u>   |                 |
| REAR BAND ADJUSTMENT - POWER FLOW IN DRIVING POSITION.....  | 5               |
| FRONT CLUTCH - REAR CLUTCH - BANDS - FRONT SERVO.....   | 6               |
| REAR SERVO - CONTROL SYSTEM - FRONT OIL PUMP - REAR OIL PUMP -<br>OIL PRESSURE REGULATOR VALVE ASSEMBLY.....  | 8               |
| <u>TRANSMISSION:</u> REMOVAL AND INSTALLATION.....  | 10              |
| <u>CONVERTER HOUSING:</u> REMOVAL AND INSTALLATION.....   | 11              |
| <u>CONVERTER ASSEMBLY:</u> REMOVAL AND INSTALLATION.....  | 12              |
| <u>CONVERTER DRIVE PLATE:</u> REMOVAL AND INSTALLATION.....   | 12              |
| <u>TRANSMISSION OVERHAUL:</u> REMOVAL OF SUB-ASSEMBLIES.....  | 12              |
| <u>GENERAL INSPECTION</u>   |                 |
| OUTPUT SHAFT AND PRIMARY SUN GEAR SHAFT - DISTRIBUTOR AND<br>SLEEVE - PINION CARRIER - EXTENSION HOUSING..... | 21              |
| <u>REPAIR AND ASSEMBLY OF SUB-ASSEMBLIES</u>  |                 |
| GENERAL INSTRUCTIONS - PRIMARY SUN GEAR SHAFT - REAR CLUTCH.....  | 24              |
| PINION CARRIER - EXTENSION HOUSING.....   | 24              |
| FRONT CLUTCH.....   | 26              |
| FRONT PUMP.....   | 29              |
| REAR PUMP - PRESSURE REGULATOR BODY.....  | 33              |
| CONTROL VALVE BODY.....   | 35              |
| GOVERNOR.....   | 36              |

|   | PAGE NO.           |
|---|--------------------|
| FRONT SERVO - REAR SERVO.....   | 38                 |
| <u>TRANSMISSION CASE AND LINKAGE</u>  |                    |
| DISASSEMBLY - INSPECTION OF TRANSMISSION CASE - INSPECTION OF LEAKAGE - ASSEMBLY.....   | 39                 |
| <u>INSTALLATION OF SUB-ASSEMBLIES</u>   |                    |
| CLUTCH ASSEMBLIES - PINION CARRIER AND OUTPUT SHAFT - REAR PUMP - GOVERNOR - DISTRIBUTOR.....   | 42                 |
| EXTENSION HOUSING - BRAKE ANCHOR BRACKET - FRONT PUMP - CHECK TRANSMISSION END PLAY - FRONT SERVO - REAR SERVO - PRESSURE REGULATOR BODY..... | 43                 |
| CONTROL VALVE BODY - FRONT SERVO ADJUSTMENT AND REAR SERVO ADJUSTMENT FLUID SCREEN AND PAN.....   | 44                 |
| <u>ADJUSTMENTS</u>  |                    |
| ENGINE IDLE SPEED - MANUAL LINKAGE.....   | 44                 |
| STARTER NEUTRAL SWITCH - KICKDOWN SWITCH - VACUUM CONTROL UNIT.....   | 45                 |
| CONTROL PRESSURES.....  | 46                 |
| CHECKING CONVERTER OPERATION.....   | 46                 |
| DRIVING UNITS (CHART) - TORQUE SPECIFICATIONS (CHART) - ROAD TEST AND PERFORMANCE CHECKS.....   | 48                 |
| FINAL DIAGNOSIS.....  | 48                 |
| <u>TRANSMISSION FAILURES</u>  |                    |
| CAUSES AND CORRECTION.....  | 48, 49, 50, 51, 52 |
| RECOMMENDED BAND ADJUSTMENT - MILEAGE INTERVALS   |                    |
| RECOMMENDED AUTOMATIC TRANSMISSION FLUID.....   | 53                 |

## THE AUTOMATIC TRANSMISSION

### Description

The transmission combines a hydraulic torque converter with a fully automatic gear system, Fig. 1, which consists of two multiple disc clutches, primary sun gear, secondary sun gear, primary and secondary pinions held in a common carrier, and an internal gear to which the transmission output shaft is attached.

selector lever may be moved from "L" to "D" at any speed.

### "R" - REVERSE

Bring the car to a full stop, position the selector lever in the "R" position and upon depressing the accelerator pedal, the car will move in the reverse direction. To rock the car back and forth, maintain a steady pressure on the accelerator pedal and move the selector lever back and forth between the "R" and the "L" positions.

### DRIVING INSTRUCTIONS

Operation of the automatic transmission is controlled by a selector lever mounted on the steering column. The position of the lever is indicated by the quadrant pointer. The selector lever has the following four positions:

### DOWNSHIFT

When maximum acceleration is desired in order to pass a slow moving vehicle or to negotiate a steep grade, the transmission may be down-shifted from high to intermediate by fully depressing the accelerator pedal. If the pressure is released on the pedal, the transmission will automatically upshift to high.

### NEUTRAL - DRIVE - LOW - REVERSE

Driving the Car

### "D" - DRIVE RANGE

All normal forward driving is done with the selector lever in the "D" (drive) position. In this position, the transmission will automatically upshift low to intermediate to direct and downshift direct to intermediate to low at speeds varying with throttle movement.

### Pushing the Car to Start the Engine.

Should it be necessary to start the engine by pushing or towing, move the selector lever to the "N" (neutral) position. When the vehicle reaches a speed of approximately 15-20 m.p.h., turn the ignition switch on and move the selector lever to the "D" (drive) position. NOTE: It is recommended that the car be pushed rather than towed, because the car will attain considerable speed as soon as the engine starts unless the brakes are applied immediately.

### "L" - LOW RANGE

This range is used for ascending very steep grades or pulling through deep sand, mud, or snow. Low is also used when descending steep grades in order to take advantage of the additional braking effort from the engine. When starting from a standstill in "L" range, the transmission will not upshift into a higher ratio. The selector lever may be moved from "D" to "L" at any speed. The transmission will shift either directly into low or into intermediate and then to low depending on the vehicle speed. Once in low, the transmission will remain in this ratio regardless of engine speed. The

### Towing Car

If the transmission is inoperative, the car should be towed with the rear end picked up, or the rear driveshaft should be removed. NOTE: Do not tow in excess of 40 m.p.h.

## MAINTENANCE

### Checking Fluid Level

Check the transmission fluid level at 1,000 mile intervals, using the following procedures:

Apply the hand brake, then place the transmission selector lever in the "N" (neutral) position. Run the engine at idle speed for about four minutes. When the engine and transmission have reached their normal operating temperatures, move the selector lever through all the positions to make sure that the fluid is distributed throughout the transmission. Return the selector lever to "N" (neutral).

Raise the hood, then clean all dirt from the transmission fluid level dipstick cap before removing the dipstick (Fig. 2). Pull the dipstick out of the tube, wipe it clean, then insert it back in the tube. Be sure that the dipstick is pushed down all the way. Remove the dipstick and check the fluid level. If necessary, add enough Automatic Transmission Fluid, Type "A" to raise the fluid level to the "F" (full) mark on the dipstick. Add oil through the dipstick tube.

### Changing Transmission Fluid

The transmission fluid should be changed and the bands should be adjusted at 15,000 mile intervals. When changing the fluid, use the following procedures:

Remove one of the converter drain plugs. Rotate the converter 180 degrees and remove the other drain plug. Disconnect the fluid filler tube at the transmission oil pan. Drain the fluid from the transmission, then remove the oil pan. Clean the pan and fluid screen thoroughly, then install it on the transmission.

Connect the fluid filler tube to the transmission oil pan and tighten the connection securely. Install the drain plugs in the converter cover and tighten them to 7-10 foot-pounds torque.

Add five quarts of Automatic Transmission Fluid, Type "A", to the transmission through the filler tube. Run the engine at idle speed for about two minutes, then add four more quarts of fluid. Let the engine idle until it reaches its normal operating temperature. Do not race the engine.

Move the selector lever through all the positions, then place it in the "N" (neutral) position. Check the fluid level and add enough fluid to bring the level up to the "F" (full) mark on the indicator. The approximate refill capacity is 10 quarts.

### Front Band Adjustment

Drain the fluid from the transmission. Remove the oil pan, then remove the fluid screen from the transmission. Wipe out the inside of the oil pan, then clean the fluid screen. Loosen the front servo adjusting screw locknut two full turns with a 9/16 wrench. Check the adjusting screw for free rotation in the servo actuating lever. Free up the screw if necessary.

Pull back on the actuating rod, then insert the gauge block of the front band adjusting tool between the servo piston stem and adjusting screw. Tighten the adjusting screw until the wrench overruns (Fig. 3).

Clean and install the fluid screen and pan, using a new gasket. Connect the fluid filler tube to the oil pan.

Hold the adjusting screw stationary and tighten the locknut clockwise to 20-25 foot lb. torque. Remove the gauge block.

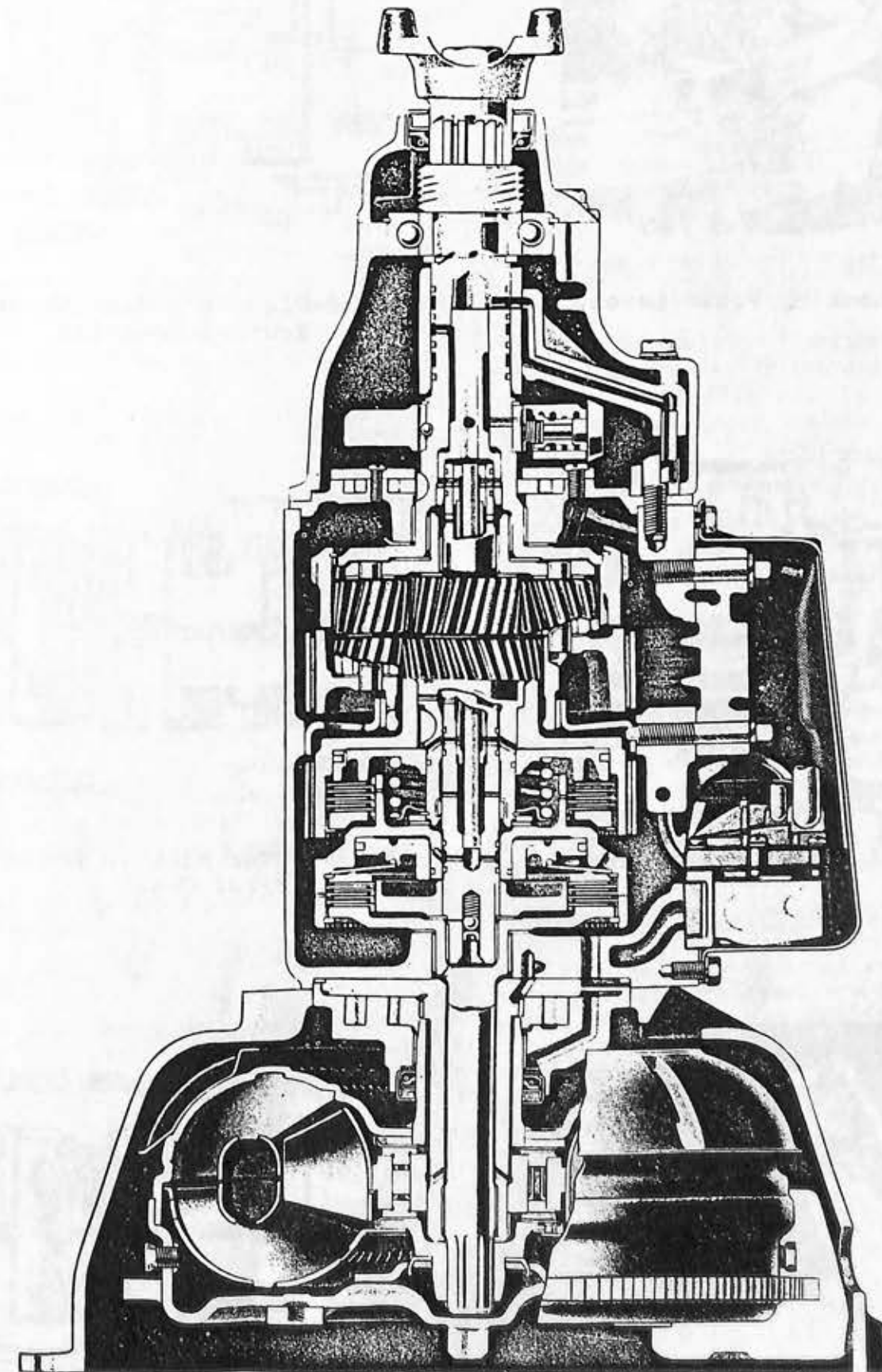

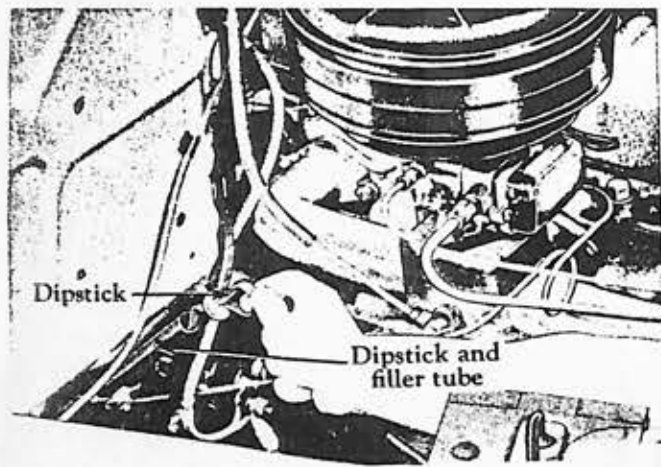

Fig. 2- Checking Fluid Level.

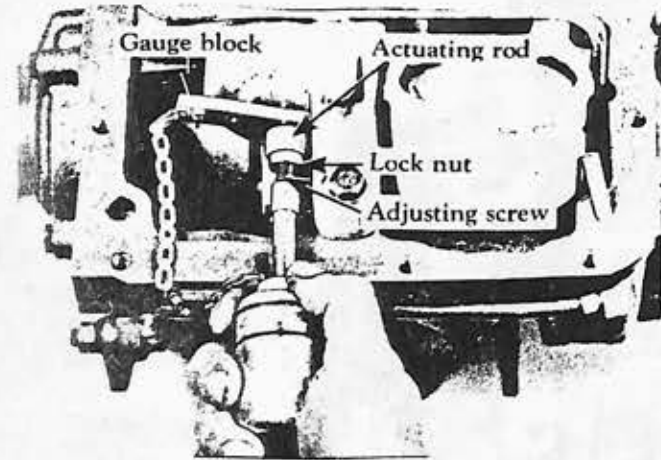

Fig. 3- Adjusting Front Band

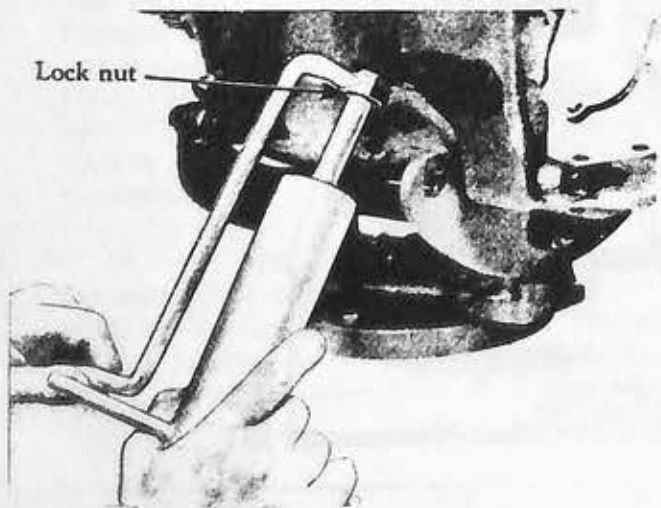

Fig. 4- Adjusting Rear Band

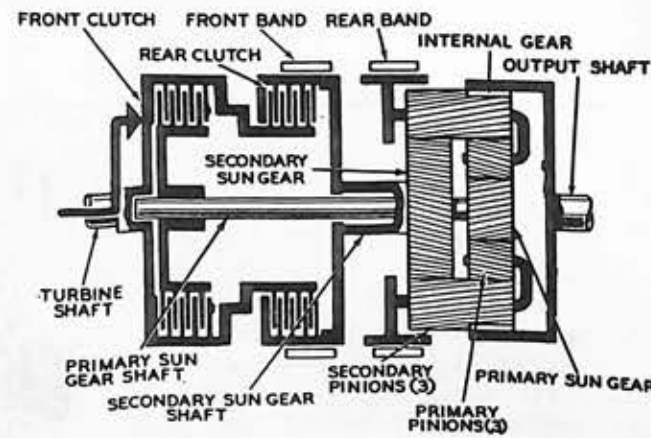

Fig. 5-Planetary Gear Train-Neutral Position

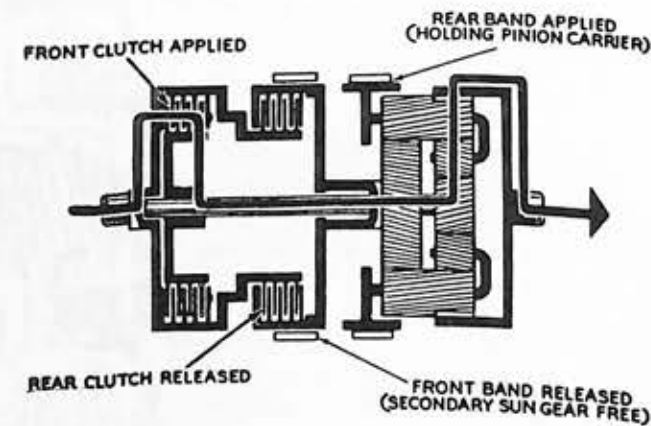

Fig. 6-Power Flow in Drive Position (First Gear).

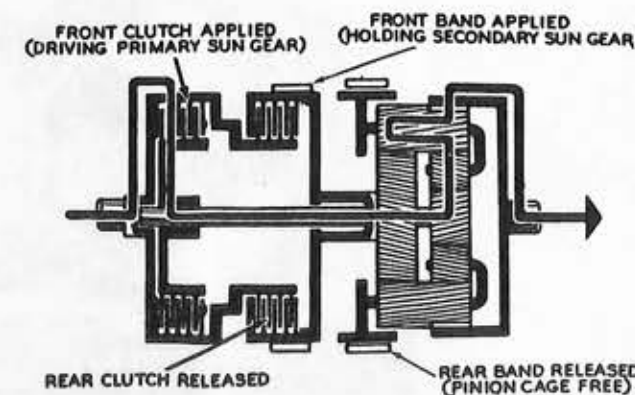

Fig. 7-Power Flow in Drive Position Intermediate (Second Gear).

Refill the transmission to the "F" (full) mark on the fluid level indicator. CAUTION: Use the fluid drained from the transmission only if it is in good condition. Add new fluid if necessary.

#### Rear Band Adjustment

Fold back the floor mat to expose the transmission cover plate. Thoroughly clean area around cover plate. Remove the cover plate from the floor board. Remove all dirt from the adjusting screw threads. Loosen the rear band adjusting screw locknut with tool shown in Fig. 4.

Using the T-handle of the tool, tighten the adjusting screw until the wrench overruns.

NOTE: If the screw is tighter than wrench capacity (10 foot-pounds torque), loosen the screw several turns and re-tighten until the wrench overruns.

Back off the adjusting screw one and one-half turns. Hold the adjusting screw stationary and tighten the adjusting screw locknut to approximately 35-40 foot-pounds torque.

CAUTION: Severe damage may result if the adjusting screw is not backed off exactly one and one-half turns.

Install the cover plate, then replace the floor mat.

#### Planetary Gear Train

The planetary gear train provides the forward and reverse drive ratios needed for smooth performance and efficient operation of the car.

A means of driving and holding the proper parts of the planetary gear train is required to transmit power from the turbine and to obtain the various combinations required for the gear ratios. This is accomplished by the two multiple disc clutches, front and rear shown in Fig. 5.

The operation of the gear train members, held or driven to provide the various ranges, is described as follows:

#### NEUTRAL

When the transmission is in the neutral position, none of the gear train members are held or driven. Therefore, no power is transmitted to the output shaft, Fig. 5.

#### POWER FLOW IN DRIVE POSITION (FIRST GEAR)

In drive position (first gear), the primary sun gear is driven and the pinion carrier is held, (Fig. 6). Power is transmitted to the primary pinions, the secondary pinions, and the internal gear, driving the internal gear in the same direction as the primary sun gear. The secondary sun gear turns free in the reverse direction and has no effect on the gear train. The pinion carrier is held against rotation.

#### POWER FLOW IN DRIVE POSITION INTERMEDIATE (SECOND GEAR)

Intermediate range or second gear is accomplished by driving the primary sun gear and holding the secondary sun gear, (Fig. 7). The primary pinions drive the secondary pinions, causing them to "walk" around the secondary sun gear carrying the internal gear and output shaft around with them.

#### POWER FLOW IN DRIVE POSITION-DIRECT

In high range or third gear, the primary and secondary gears are locked together and driven as a unit (Fig. 8). Therefore, the pinions cannot rotate and the entire planetary train revolves as a unit, which causes the output shaft to rotate at the same speed as the turbine shaft.

#### POWER FLOW IN "L" LOW RANGE

In low range, the primary sun gear is driven and the pinion carrier is held, (Fig. 9). Power is transmitted to the primary pinions, the secondary pinions, and the

internal gear, driving the internal gear in the same direction as the primary sun gear. The secondary sun gear turns free in the reverse direction and has no effect on the gear train. The pinion carrier is held against rotation.

#### POWER FLOW IN "R" REVERSE

Reverse range is accomplished by driving the secondary sun gear and holding the pinion carrier (Fig. 10). The secondary pinions drive the internal gear in the reverse direction. The primary sun gear and the primary pinions rotate freely and have no effect on the gear train.

#### FRONT CLUTCH

The front clutch assembly consists of the front clutch cylinder, front clutch piston, release spring, four steel drive plates and four clutch driven plates with composition facings (Fig. 11). The drive plates are connected to the turbine shaft, while the driven plates are connected to primary sun gear shaft.

The front clutch is operated by fluid pressure against the front clutch piston. The piston is moved against a spring washer which increases the "apply" force through lever action to lock the multiple disc clutch. When the clutch is applied, the primary sun gear is locked to the turbine shaft to drive the primary sun gear. The primary sun gear is driven in all forward speeds. The piston is returned to the release position by the spring washer when the fluid pressure is removed (Fig. 11).

#### REAR CLUTCH

The rear clutch consists of a rear clutch drum, rear clutch piston, release spring, four steel clutch driven plates, and four clutch drive plates with composition facings (Fig. 12). The rear clutch drive plates are connected to the front clutch drum and the four driven plates are connected to the secondary sun gear. A heavy release spring is used in the rear clutch assembly. The rear clutch is operated by fluid pressure against the rear clutch pis-

ton. Movement of the piston compresses the release spring, then locks the multiple disc clutch. When the rear clutch is applied, the secondary sun gear is driven in reverse ratio and in the drive range high ratio. The piston is returned to the released position by the rear clutch release spring (Fig. 12).

#### BANDS

The bands are made of steel and have composition linings bonded to the inside surfaces. The front has one end anchored against a boss in the transmission case, while the opposite end of the band engages a strut between the band and front servo actuating lever. When fluid pressure is introduced to the front servo, the piston is forced inward against the release spring, applying the front band around the drum. When the band is held tightly around the drum, it prevents the secondary sun gear from turning. The front band is applied in the intermediate ratio.

The rear band has one end contacting a strut on the inner end of the rear band adjusting screw. The opposite end of the band engages the strut between the band and the rear servo actuating lever. Fluid pressure directed to the rear servo piston applies the band around the drum and prevents the pinion carrier from rotating. When the fluid pressure is removed, the rear band is released by the rear servo-return spring pressure. The rear band is applied in drive first as well as in low and reverse ratios.

#### FRONT SERVO

The front servo assembly consists of a cast aluminum body, servo piston, piston guide, release spring, and an actuating lever. The inner end of the lever contacts the piston stem and the outer end contacts the front band strut. The piston is moved by fluid pressure which exerts force against the inner end of the actuating lever. Force is transmitted through a strut between

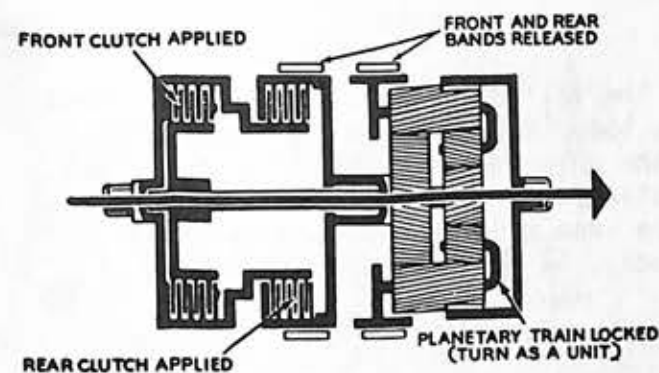

Fig. 8- Power Flow in Drive Position (Direct)

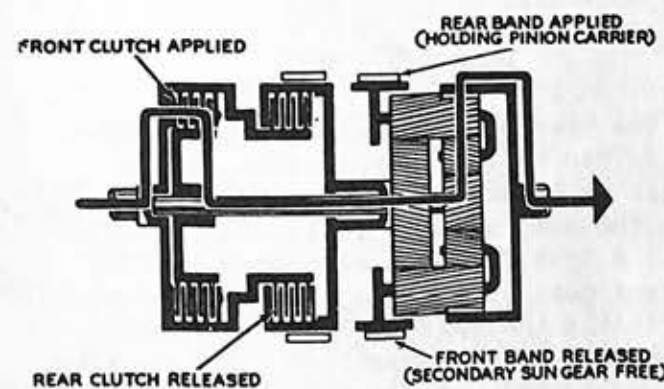

Fig. 9- Power Flow in "L" Low Range.

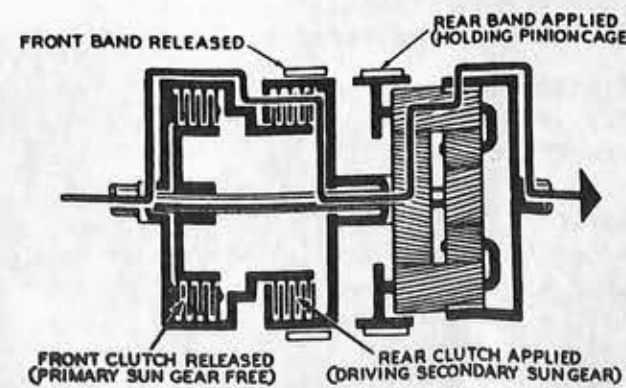

Fig. 10- Power Flow in "R" Reverse.

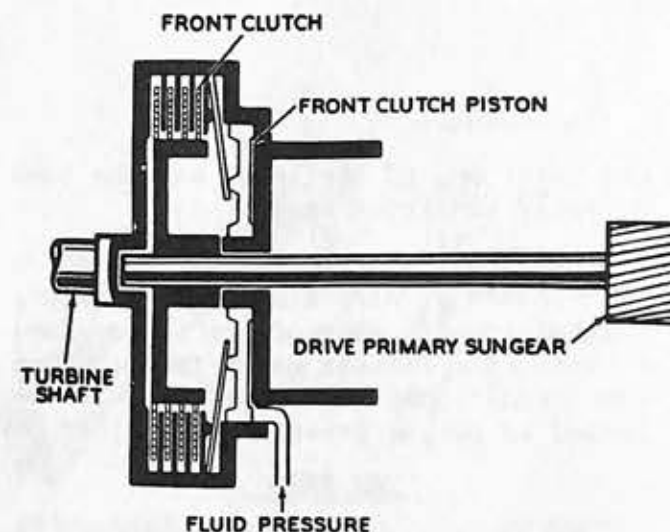

Fig. 11- Front Clutch

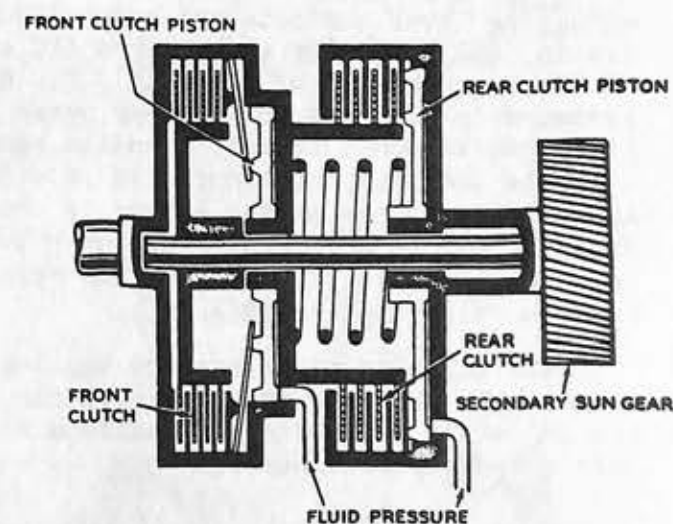

Fig. 12- Rear Clutch

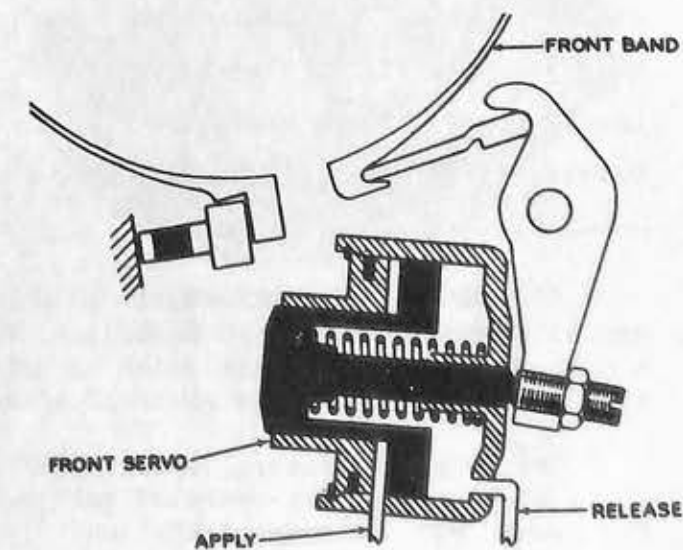

Fig. 13- Front Servo Operation.

the outer end of the lever and the band to apply the front band.

Under certain conditions, the servo is released by directing fluid pressure to the opposite side of the piston, assisted by the release spring force. Under some conditions, the front servo is released by spring pressure only (Fig. 13).

#### REAR SERVO

The rear servo assembly consists of a cast aluminum body, servo piston, accumulator piston spring, accumulator piston, servo release spring, and an actuating lever (Fig. 14). The inner end of the actuating lever contacts the accumulator piston, and the outer end engages one end of the rear band strut (Fig. 15). Fluid pressure is directed to the rear servo piston to force it inward. When the band contacts the drum, cushioning is provided as the accumulator piston spring is compressed. As the accumulator piston bottoms in the servo piston bore, the rear band is fully applied (Fig. 15).

The clutches and bands are applied by pressure from the hydraulic control system in the following combinations to obtain the desired gear ranges:

| Ratio           | Apply                   |
|-----------------|-------------------------|
| Neutral.....    | No clutches or bands    |
| First (2.40:1)  | Front clutch-rear band  |
| Second (1.47:1) | Front clutch-front band |
| High (1:1)....  | Front clutch-rear band  |
| Low (2.40:1)..  | Front clutch-rear band  |
| Reverse (2:1).  | Rear clutch-rear band   |

#### CONTROL SYSTEM

The control system consists of a manual selector lever for the driver, and a hydraulic control system which is sensitive to throttle position and road speed.

The hydraulic control system consists of hydraulically-operated valves, two pumps, and the connecting lines.

The valves are mounted in the control valve body, the pressure regulator body, and the governor body. When the pumps are operating, fluid in a sump at the bottom of the transmission case passes, under pressure, to the control system.

#### FRONT OIL PUMP

The front oil pump is a crescent type, high volume pump mounted on the front face of the transmission case. A tube connects the sump to the intake side of the pump. Impeller hub drive lugs contact bosses on the front pump drive gear to drive the pump at engine speed. Fluid from the pump is directed to the oil pressure regulator valve assembly.

#### REAR OIL PUMP

The rear oil pump is a crescent type pump driven by the transmission output shaft. An intake tube is connected between the sump and the intake side of the pump. A tube from the discharge side of the rear pump is used to direct fluid pressure to the pressure regulator assembly and control valve assembly. A lubrication tube, connected between the pressure regulator body and the rear pump, provides lubrication for the transmission.

#### OIL PRESSURE REGULATOR VALVE ASSEMBLY

The oil pressure regulator valve assembly consists of a cast aluminum body, control pressure regulator valve and spring, converter pressure regulator valve and spring, and a spring retainer, (Fig. 16).

A stamped steel spring seat and stem assembly is used at the end of the control pressure regulator valve, and a steel sleeve is used as a guide and stop inside the converter pressure regulator spring. A boss cast on the top of the pressure regulator valve body and a slot in the base of the body casting are used to lock the spring retainer in position on the body.

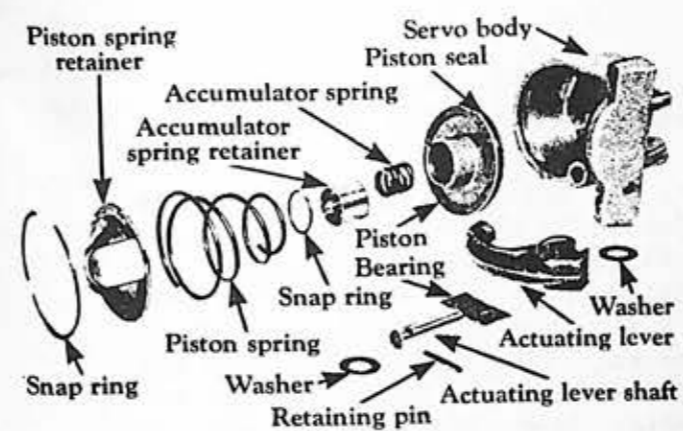

Fig.14- Exploded View of Rear Servo.

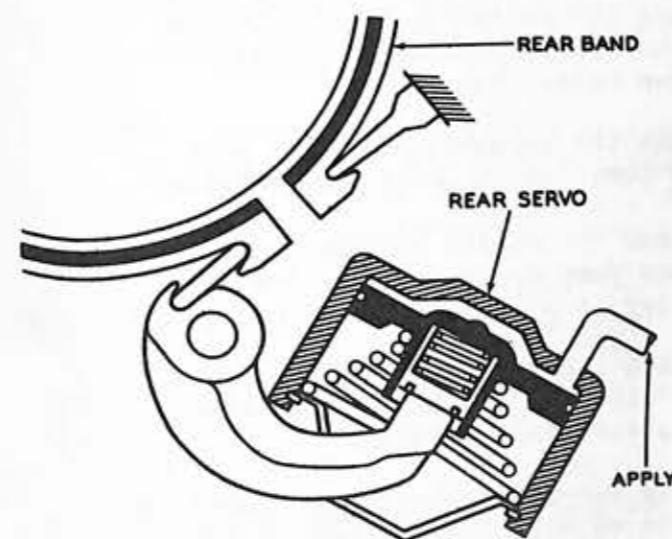

Fig.15- Rear Servo Operation

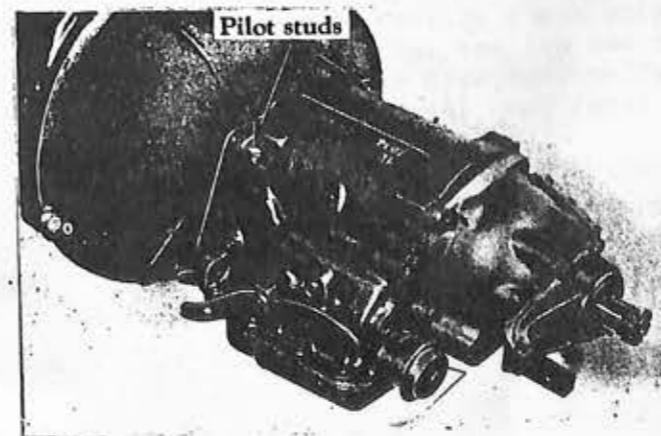
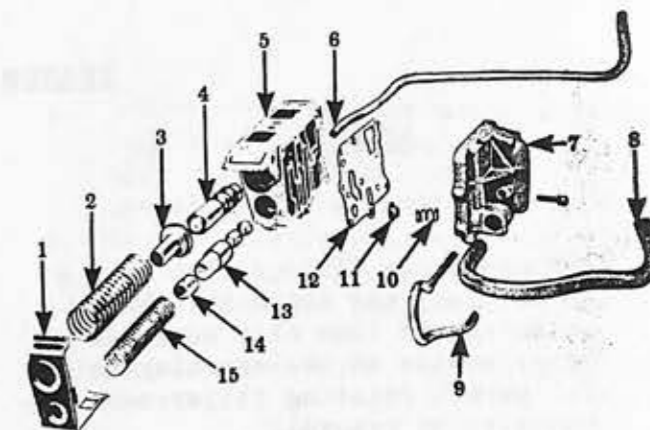

Fig.17- Removal of Transmission using Pilot Studs.



1. RETAINER.
2. SPRING, control pressure valve.
3. SLEEVE AND RETAINER.
4. VALVE, control pressure.
5. BODY, regulator.
6. TUBE, lubrication.
7. COVER.
8. TUBE, control pressure.
9. TUBE, compensator pressure.
10. SPRING, front pump check valve.
11. VALVE, front pump check.
12. PLATE, separator.
13. VALVE, converter pressure.
14. SPACER.
15. SPRING, converter pressure valve.

Fig.16- Oil Pressure Regulator Assembly.

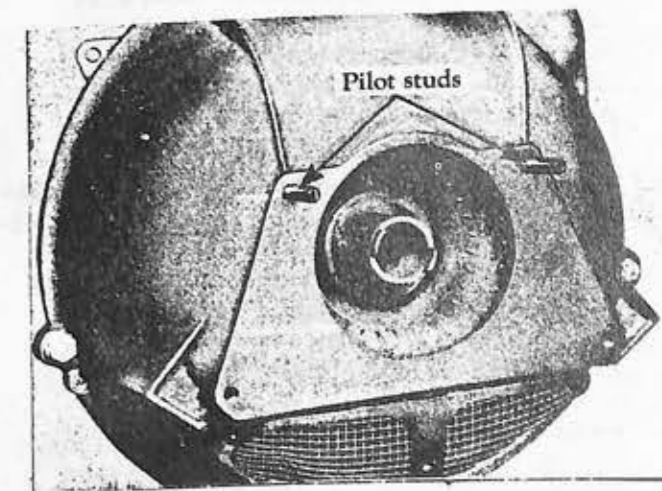

Fig.18- Installation of Studs for Mounting Transmission.

## TRANSMISSION

### REMOVAL

1. Raise the vehicle with a hoist.
2. Disconnect the fluid filler tube at the oil pan, and drain the fluid. Loosening the tube clip capscrew at the extension on the starting motor will permit rotating filler tube for transmission removal.
3. Disconnect the vacuum line at vacuum unit located at rear of transmission.
4. Disconnect the speedometer cable at speedometer adapter on transmission.
5. Disconnect the hand brake cable at drive shaft brake if chassis is so equipped.
6. Disconnect the shift linkage at manual shift lever on transmission.
7. Disconnect the two oil cooler lines on right side of transmission if chassis is so equipped.
8. Disconnect the propeller shaft at transmission companion flange.  
**NOTE:** Wire the end of the propeller shaft to the frame to permit transmission removal.
9. Place the hydraulic hoist with a suitable transmission lift cradle in position under the transmission oil pan. Adjust the hoist to align the cradle to the transmission oil pan flange so that the weight of the transmission case is supported by the hoist.
10. Remove the transmission case to converter housing upper capscrews and lockwashers. Install the two pilot studs into the capscrew holes (Fig. 17).
11. Remove the lower transmission case to converter housing capscrews and lockwashers.

12. With the hydraulic hoist and cradle adjusted so the transmission case is in alignment with the converter housing, pull the transmission rearward with the hydraulic hoist to disengage the transmission from the converter housing and converter assembly. Lower the assembly and remove it from the vehicle.

### INSTALLATION

1. Install the two transmission pilot studs in the two top transmission to converter housing attached capscrew holes (Fig. 18).
2. Mount the transmission on a jack and position it under the vehicle.
3. Rotate the engine to position the front pump drive lugs on the converter in a vertical position.
4. Rotate the front pump to position the slots in the pump drive gear in a vertical position.
5. Apply lubricant similar to lubricate to seal the surface on the converter impeller cover hub.
6. Raise the transmission and move it toward the front of the vehicle, positioning it into the converter housing and converter.  
**CAUTION:** Be sure to align the turbine shaft splines with the turbine hub splines and the converter impeller lugs with the slots in the front pump drive gear.

7. Install the lower transmission to converter housing attaching capscrews. Remove the two pilot studs and install the two upper attaching capscrews. Tighten the capscrews securely.

8. Connect the two oil cooler lines on the right side of the transmission if the chassis is so equipped.
9. Connect the shift linkage at the manual shift lever on the transmission. Make sure it is properly adjusted.
10. Connect the hand brake cable to the drive shaft brake if the chassis is so equipped.
11. Connect the speedometer cable to the speedometer adapter on the transmission.
12. Connect the vacuum line to the vacuum unit located at rear of transmission.
13. Connect the fluid filler tube to the oil pan. Tighten the fitting securely. Also tighten the tube clip capscrews at the extension on the starting motor.
14. Connect the propeller shaft to the transmission companion flange. Tighten the mounting capscrews securely and lock the capscrews with lockplates.
15. Lower the vehicle to the floor. Fill the transmission with five quarts of Automatic Transmission Fluid, Type "A", then check the fluid level with the transmission at normal operating temperature. Add oil if necessary.
16. Road test the vehicle to check performance and shift points.

### CONVERTER HOUSING

#### REMOVAL

1. Perform the necessary operation outlined under TRANSMISSION, "REMOVAL."
2. Disconnect the solenoid wires and the battery cable at the starting motor. **NOTE:** Protect the end of the battery cable to avoid a short circuit.

3. Remove the starting motor attaching capscrews and lockwashers and remove the starting motor.
4. Remove converter housing to crossmember mounting capscrews and lower insulators and retainers.
5. Remove converter housing adapter cover.
6. Raise engine sufficiently by adjusting the engine rear support, to permit removal of the converter housing upper insulators and retainers.
7. Remove the eight capscrews and lockwashers attaching converter housing to crankcase adapter. Then remove housing from adapter. **NOTE:** It may be necessary to lower the engine sufficiently to permit removal of the converter housing.

### INSTALLATION

1. Clean the rear engine plate and machined faces of the converter housing.
2. Install the converter housing and engage the dowels using care not to damage the dowels or the converter housing.
3. Install the converter housing eight attaching capscrews and lockwashers.
4. Install engine upper insulators and retainers between crossmembers and converter housing. Make sure holes in insulators and retainers are in line with holes in converter housing and crossmembers.
5. Install engine lower insulators and retainers under crossmember and attach to converter housing with bolts and lock plates. Lower converter housing and engine. Insulators must be firmly seated in retainers and crossmembers, and bolts pulled hand tight, after which they are to be



given one to one and one-half additional turns before locking.

6. Install converter housing adapter cover.
7. Install starting motor to converter housing.
8. Connect the solenoid wires and battery cable at starting motor.
9. Perform the necessary operations outlined under TRANSMISSION, "INSTALLATION."

#### CONVERTER ASSEMBLY

##### REMOVAL

1. Perform the necessary operations outlined under CONVERTER HOUSING, "REMOVAL."
2. Remove the six screws attaching the converter assembly to the drive plate and remove the converter.

##### INSTALLATION

1. Install the converter, being careful not to damage the bolt mounting threads. Coat the crankshaft pilot with lubeplate.
2. Install the six screws attaching the converter drive plate. Do not tighten at this time. NOTE: Be sure converter drain plugs have been installed and tightened.
3. Perform the necessary operations outlined under CONVERTER HOUSING, "INSTALLATION," Items 1 through 9. Be sure to space the transmission to the rear by adding four spacers between the converter housing and the transmission at each of the four mounting capscrews.
4. Perform the necessary operations outlined under TRANSMISSION, "INSTALLATION."
5. Rotate the engine and converter assembly through two complete revolutions to center the converter.

This may be accomplished by prying on the ring gear. To facilitate rotating the converter, it is advisable to remove the spark plugs in order to reduce engine compression.

6. With the converter aligned to the transmission, tighten the converter to converter drive plate attaching screws.
7. Install the converter housing adapter cover.

#### CONVERTER DRIVE PLATE

##### REMOVAL

1. Perform the necessary operations outlined under TRANSMISSION, "REMOVAL."
2. Perform the necessary operations outlined under CONVERTER HOUSING, "REMOVAL."
3. PERFORM THE necessary operations outlined under CONVERTER ASSEMBLY,
4. Remove the six attaching nuts securing the converter drive plate to the crankshaft.

##### INSTALLATION

1. Position the converter drive plate to the crankshaft, aligning all holes.
2. Apply a thin coat of a suitable sealer to the converter drive plate self-locking capscrew threads. Install and tighten to 55-65 foot-pounds.
3. Perform the necessary operations outlined under CONVERTER ASSEMBLY, "INSTALLATION."

#### TRANSMISSION OVERHAUL

##### REMOVAL OF SUB-ASSEMBLIES

Before removing any of the transmission sub-assemblies, thoroughly clean the outside of the transmission case to prevent dirt getting into the mechanism.

##### A. Oil Pan and Screen:

1. After the transmission has been removed from the vehicle, place the assembly in the transmission holding fixture (Fig. 19).

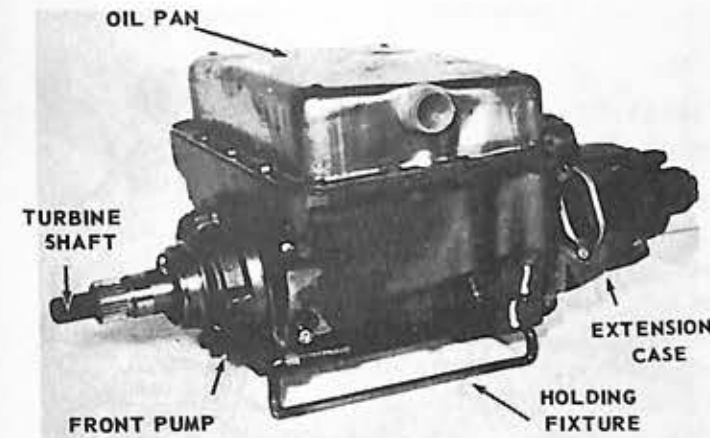

Fig. 19 TRANSMISSION MOUNTED IN HOLDING FIXTURE

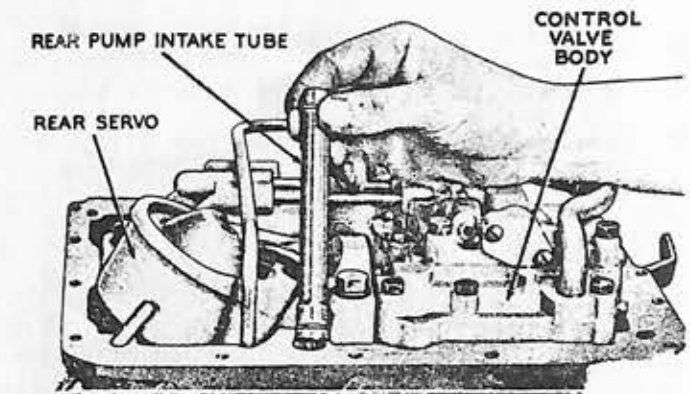

Fig. 22

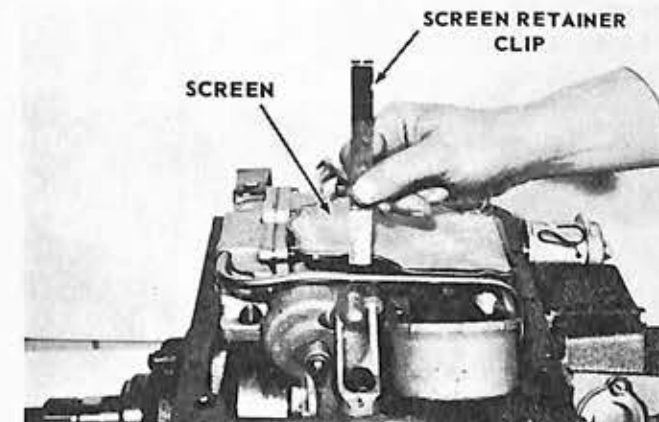

Fig. 20

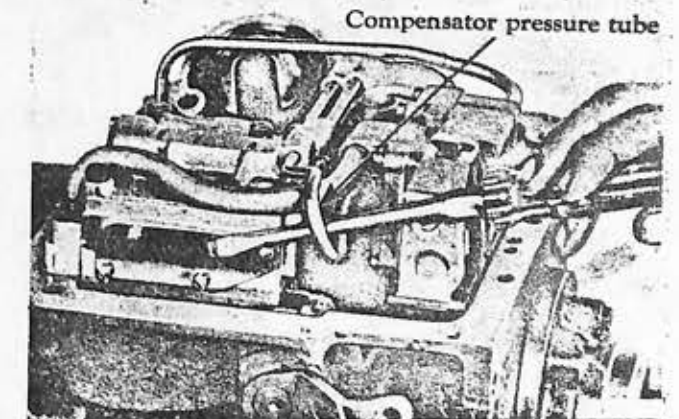

Fig. 23

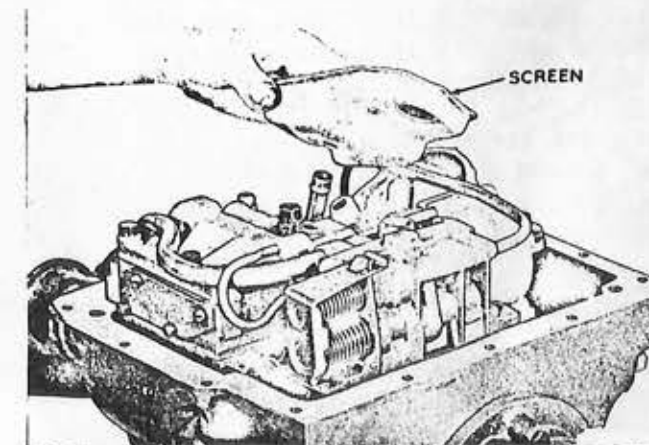

Fig. 21

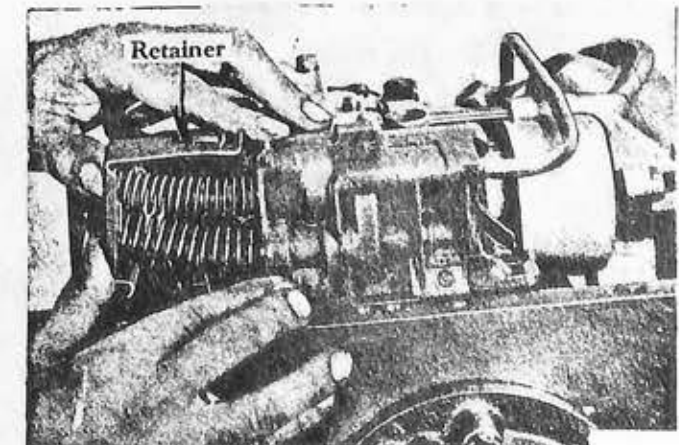

Fig. 24

2. Remove the oil pan and gasket.
  3. Remove the screen retaining clip, (Fig. 20) then lift the screen off the forward tube and off the rear tube (Fig. 21).
- B. Pressure Regulator Valve Assembly:
1. Remove the rear pump intake tube from the bore in the transmission (Fig. 22). Be careful not to bend the tube.
  2. Remove the small compensator pressure tube (Fig. 23). **NOTE:** When prying out tubes, exercise care not to distort or bend the tubes.
  3. Remove the pressure regulator valve spring retainer (Fig. 24). **CAUTION:** Maintain constant pressure on the retainer to prevent distortion of the retainer and sudden release of the springs.
  4. Remove the pressure regulator springs and pilots, but do not remove the valves (Fig. 25).
  5. Remove the large control pressure tube (Fig. 26) from the pressure regulator and the control valve body.
  6. Remove the lubrication tube (Fig. 27) from the pressure regulator and rear pump.
  7. Loosen the vacuum control and solenoid unit lock nut and remove the unit (Fig. 28).

- C. Control Valve Assembly:
1. Loosen the front and rear servo band adjusting screws five turns.
  2. Loosen the front servo attaching capscrews three turns (Fig. 29).
  3. Remove the control valve body attaching capscrews. Align the manual shift inner lever to permit removal of the valve body.

Pull the body off the servo tubes, then remove the valve body (Fig. 30). Remove the servo apply and release

by twisting and pulling at the same time.

4. Remove the regulator body attaching capscrews and washers, then remove the regulator body from the case (Fig. 31). **NOTE:** Keep the control pressure valve and the converter pressure regulator valve in the bores in the pressure regulator to avoid damage to the valves.

D. Servos:

1. Remove the front servo attaching capscrew, hold the front servo strut with the fingers, then lift the servo assembly from the case (Fig. 32).
2. Remove the rear servo attaching capscrews. Hold the actuating and anchor struts with the fingers, then lift the servo from the case (Fig. 33). **CAUTION:** Do not let the struts drop into the case.
3. With the use of snap ring pliers, remove the rear pump discharge tube (Fig. 34).

E. Check Transmission End Play:

1. Remove one of the front pump attaching capscrews. Mount the dial indicator support rod in the front pump capscrew hole. Mount a dial indicator on the support rod so that the contact rests on the end of the turbine shaft as shown in Fig. 35.
2. Pry the front clutch cylinder to the rear of the transmission with a large screwdriver (Fig. 36). Set the dial indicator to zero while maintaining a slight pressure on the screwdriver.
3. Remove the screwdriver and pry the units toward the front of the transmission by inserting the screwdriver between the large internal gear and the rear drum (Fig. 37).

Record the indicator reading for use during transmission assembly. End play should be .010 to .029 inches.

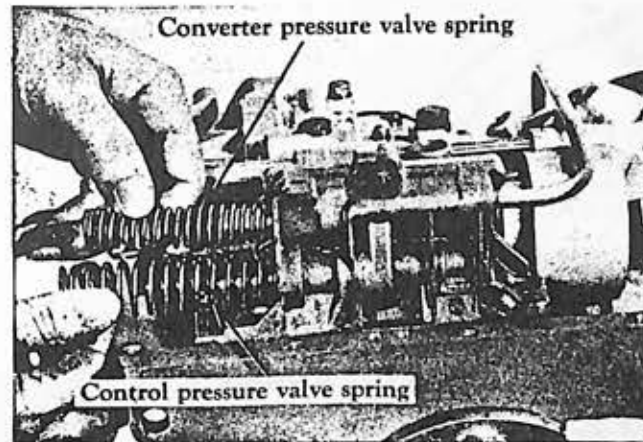

Fig. 25

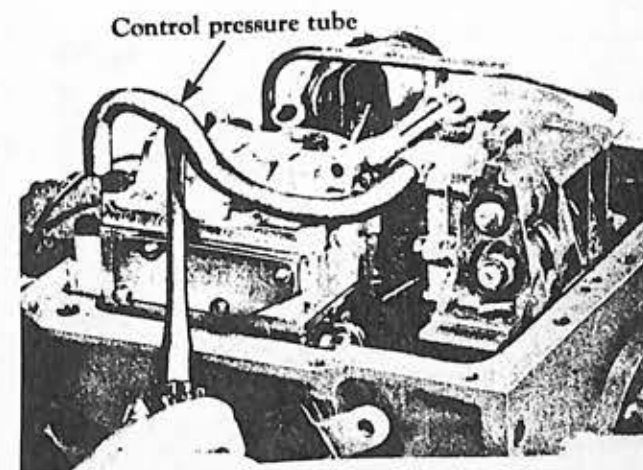

Fig. 26

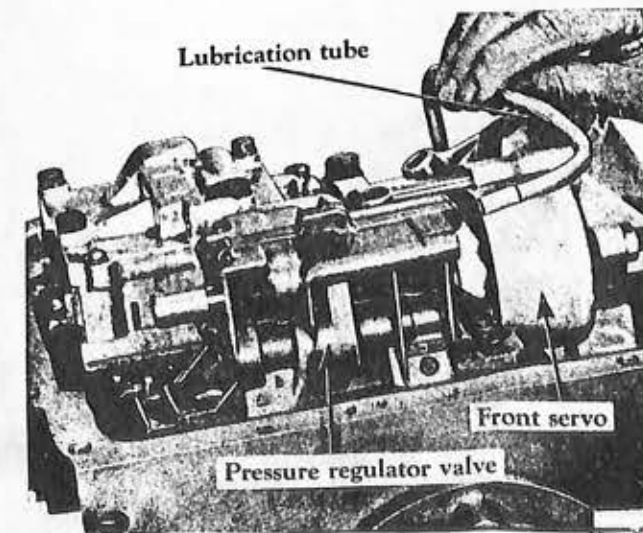

Fig. 27

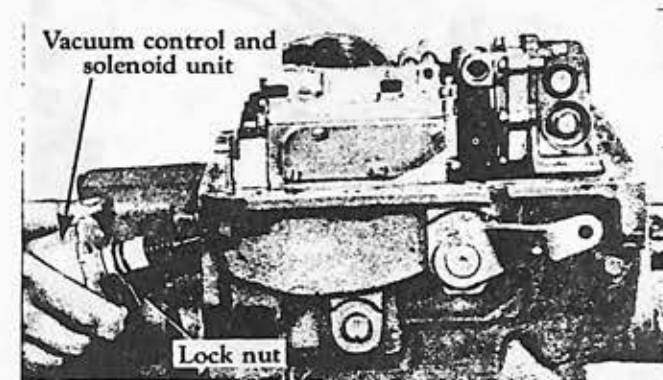

Fig. 28

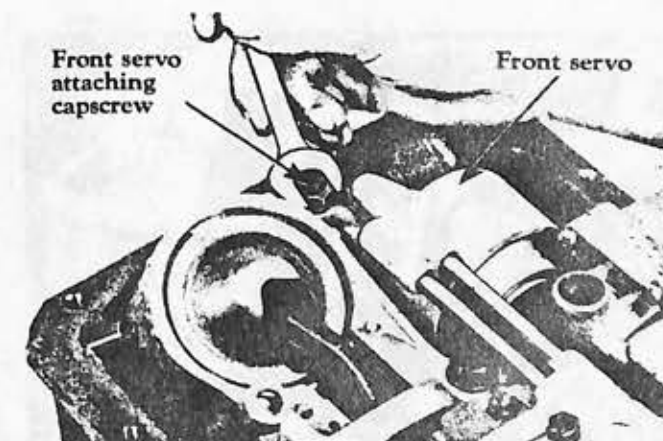

Fig. 29

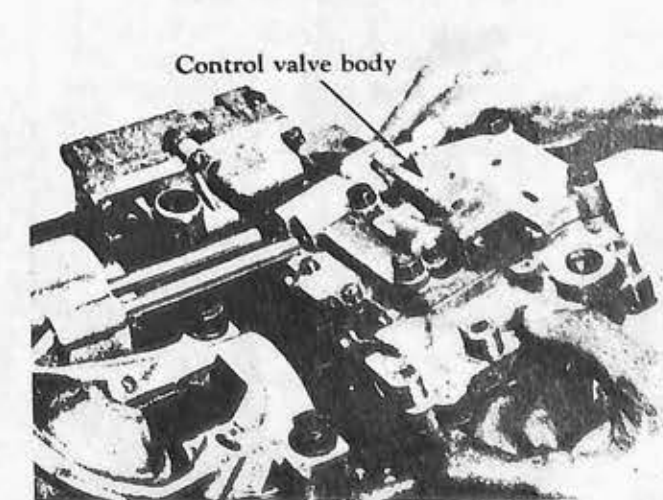

Fig. 30

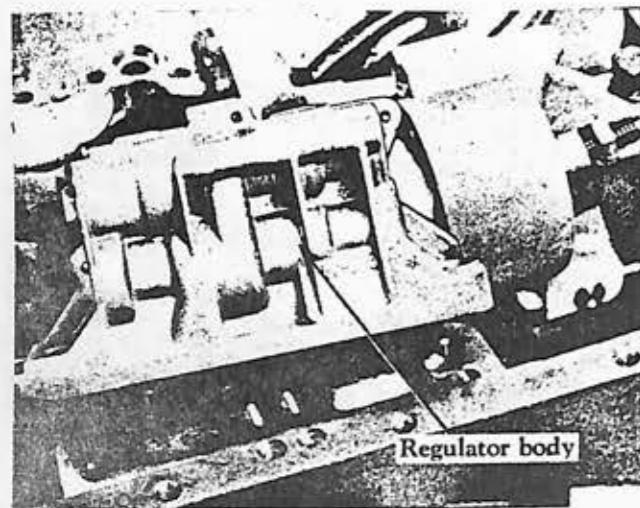

Fig. 31

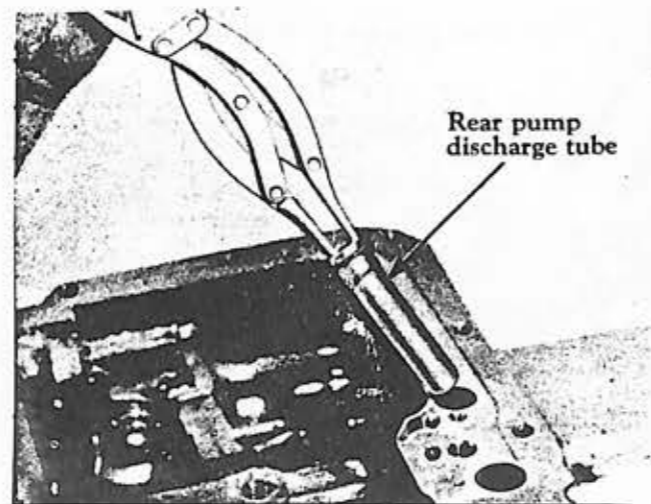

Fig. 34

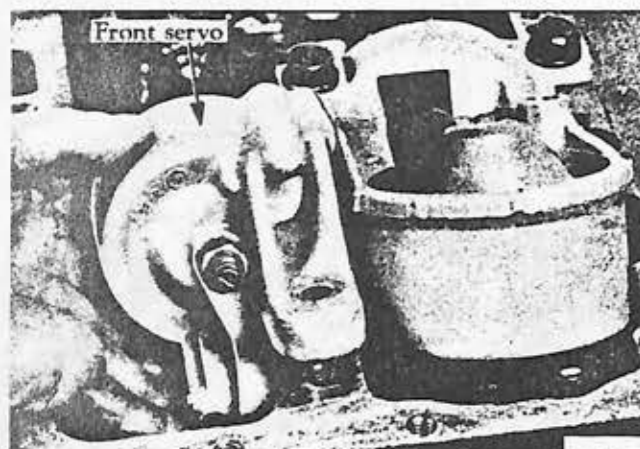

Fig. 32

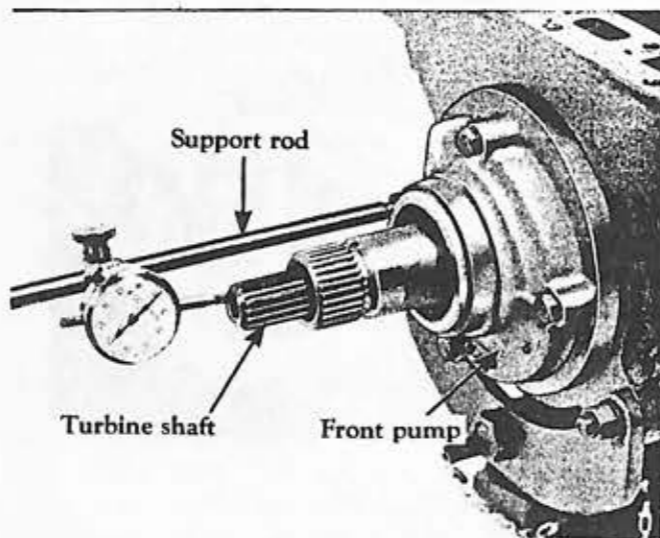

Fig. 35  
Installation of Support Rod and Dial Indicator.

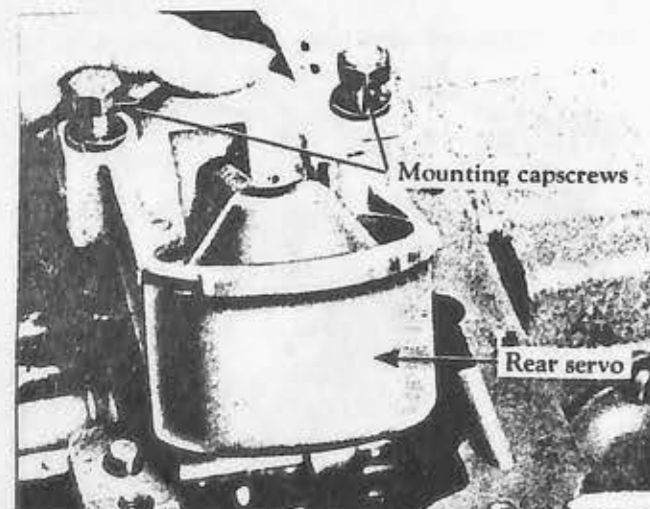

Fig. 33

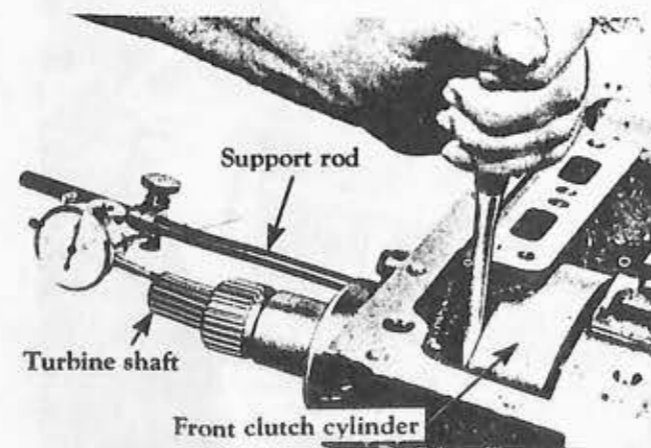

Fig. 36

4. Remove the indicator support.

F. Extension Housing:

1. Remove the governor inspection cover and gasket from the transmission extension housing (Fig. 38).
2. Pry the rear oil seal from the mainshaft bearing retainer and discard. Use a new seal upon reassembly.
3. Remove the mainshaft bearing retainer attaching capscrews and lockwashers. Remove retainer and gasket (Fig. 39).
4. Remove the speedometer drive gear (Fig. 40).
5. Remove rear bearing snap ring, using snap ring pliers (Fig. 41). Remove the bearing, using a suitable puller.
6. Remove the five transmission to extension housing capscrews. These capscrews also attach the rear pump to the case. Hold the rear pump in position and remove the extension housing and gasket (Fig. 42).
7. Remove the rear bearing spacer washer (Fig. 43).

G. Distribution:

1. Remove the distributor and tubes from the transmission (Fig. 44).
2. Remove the distributor sleeve from the output shaft, exercising care not to damage the oil seal rings (Fig. 45).
3. Remove the four oil seal rings from the output shaft with the fingers to prevent breaking the rings (Fig. 46).

H. Governor:

1. Remove the governor snap ring from the output shaft (Fig. 47).

2. Slide the governor assembly off the output shaft (Fig. 48) then remove the governor drive ball.

I. Rear Pump:

1. Remove the rear pump and gasket from the transmission case (Fig. 49).
2. Remove the rear pump drive key from the output shaft (Fig. 49).

J. Pinion Carrier:

1. Hold the rear drum forward, then remove the output shaft (Fig. 50).
2. Remove the selective thrust washer from the rear of the pinion carrier (Fig. 50).
3. Remove the pinion carrier from the primary sun gear shaft (Fig. 51).
4. Remove the two oil seal rings from the primary sun gear shaft (Fig. 51). **CAUTION:** Do not distort the rings.
5. Remove the bronze thrust washer from the primary sun gear shaft. **NOTE:** The thrust washer may come off with the pinion carrier.

K. Front Pump:

1. Remove the remaining front pump attaching capscrews, then remove the front pump assembly and gasket (Fig. 52). **NOTE:** If necessary, tap the capscrew bosses with a soft hammer to loosen the pump from the case.

L. Clutches and Primary Sun Gear Assembly:

1. The end of the rear band next to the adjusting screw has a depression in the center boss (Fig. 53). Note the rear band position for reference in assembly.

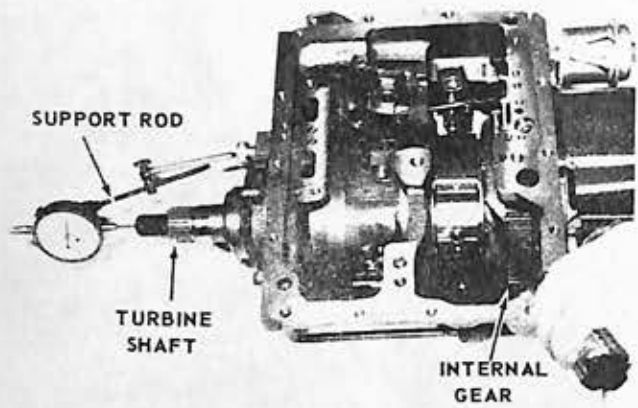

Fig. 37

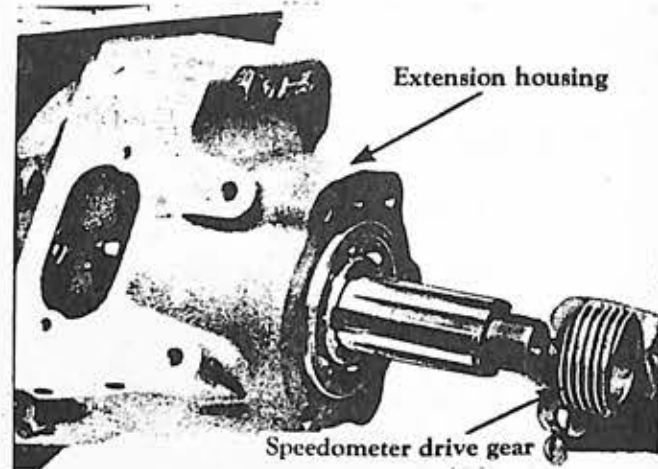

Fig. 40

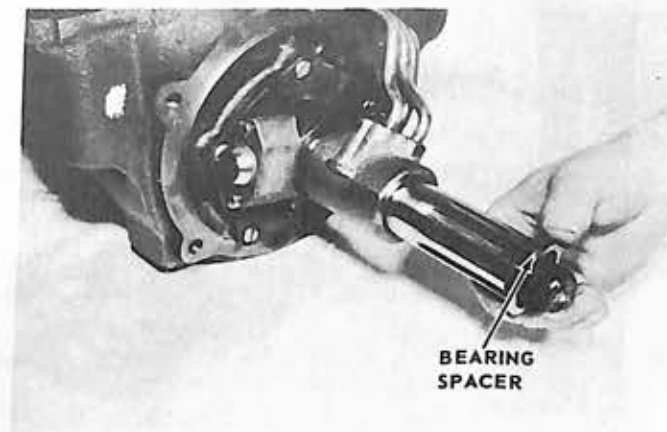

Fig. 43

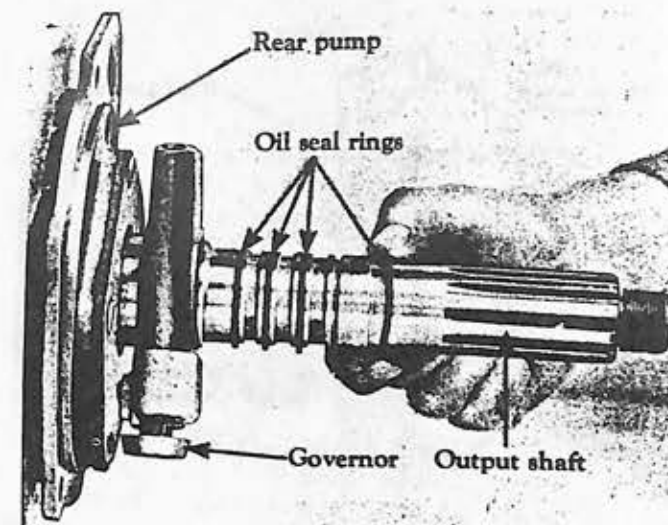

Fig. 46

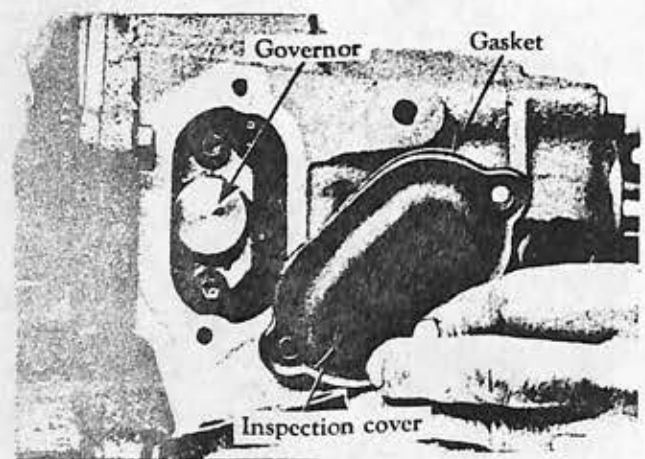

Fig. 38

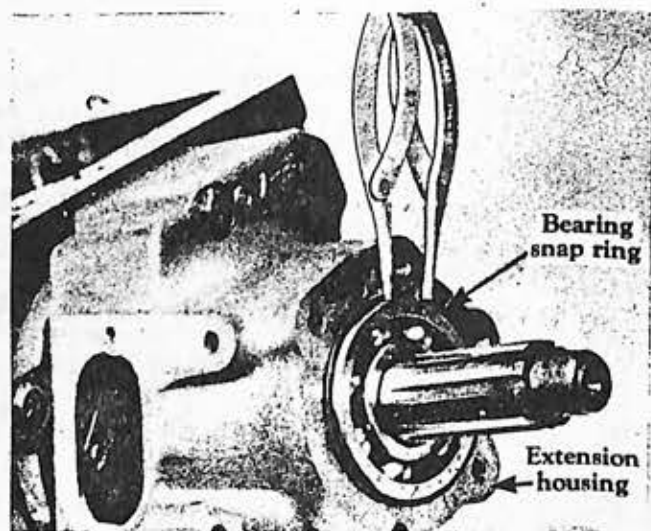

Fig. 41

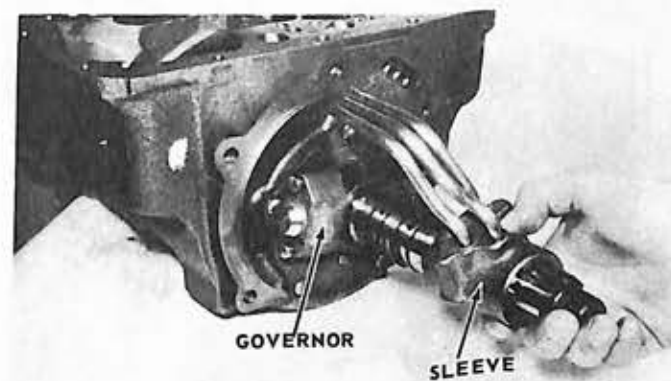

Fig. 44

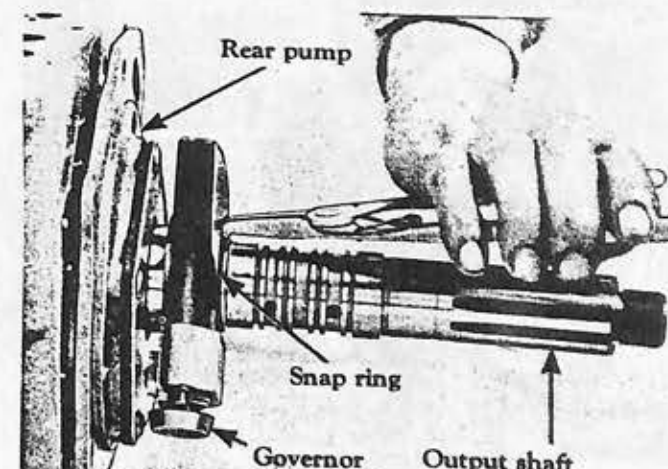

Fig. 47

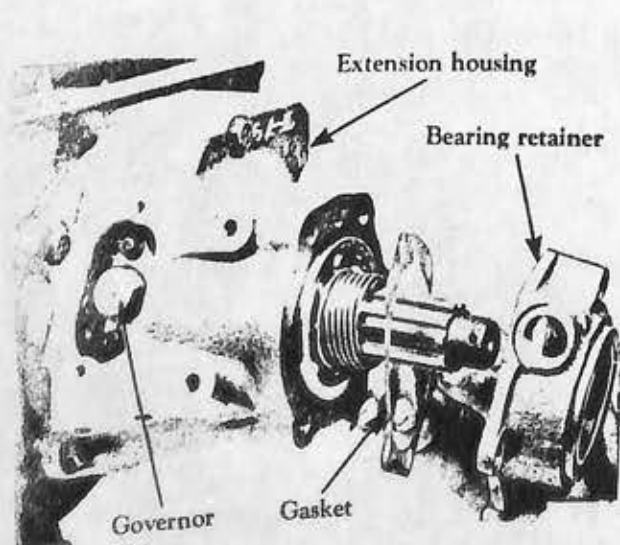

Fig. 39  
Removing Bearing Retainer or Brake  
Anchor Bracket.

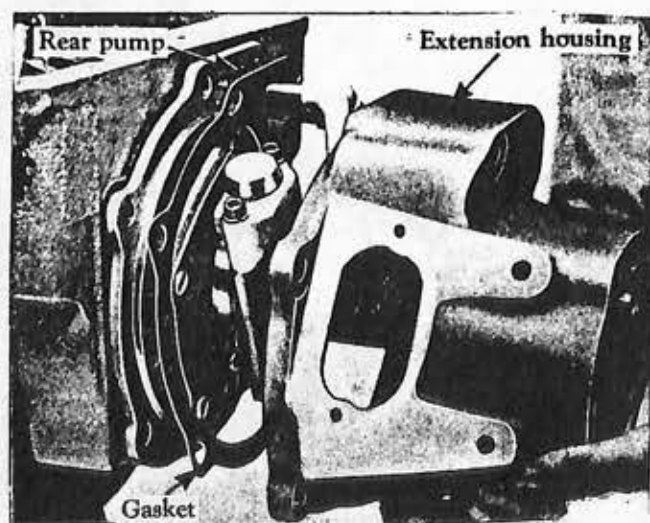

Fig. 42

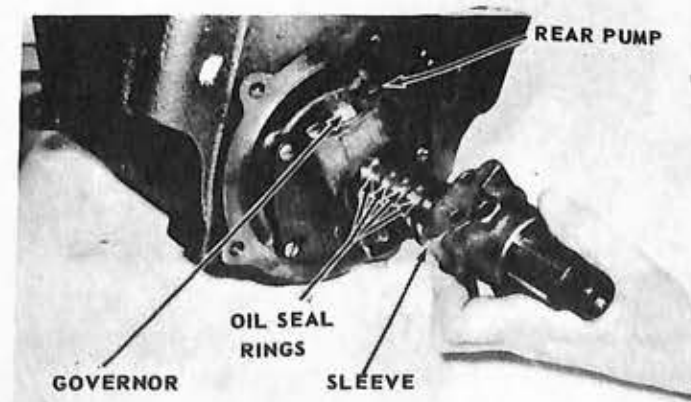

Fig. 45

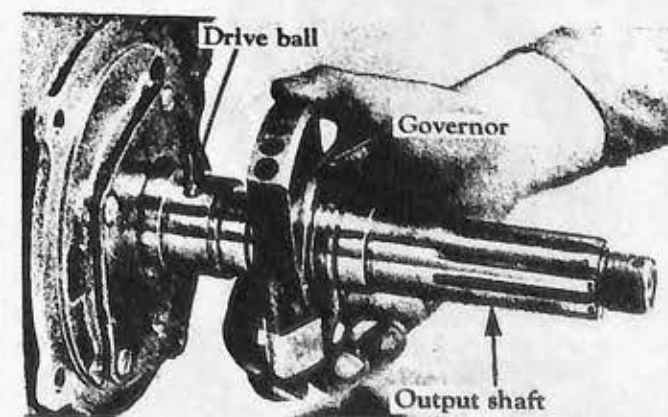

Fig. 48

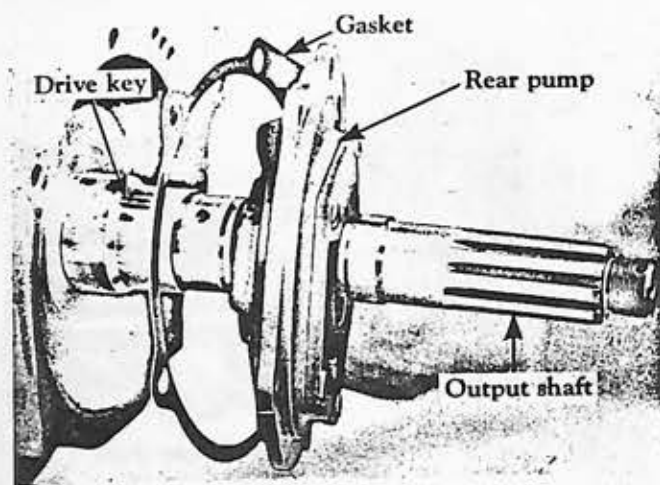

Fig. 49

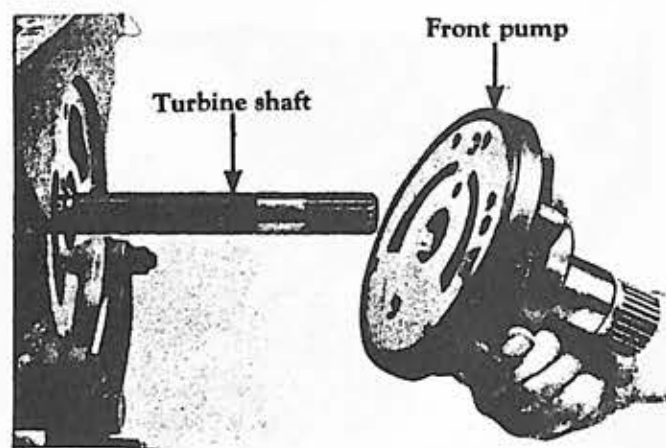

Fig. 52

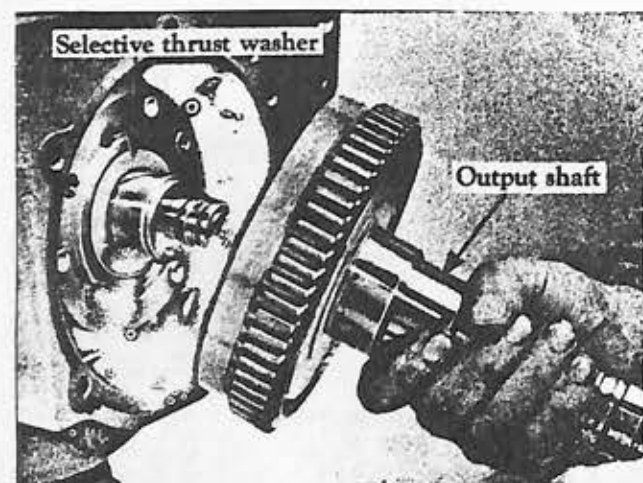

Fig. 50

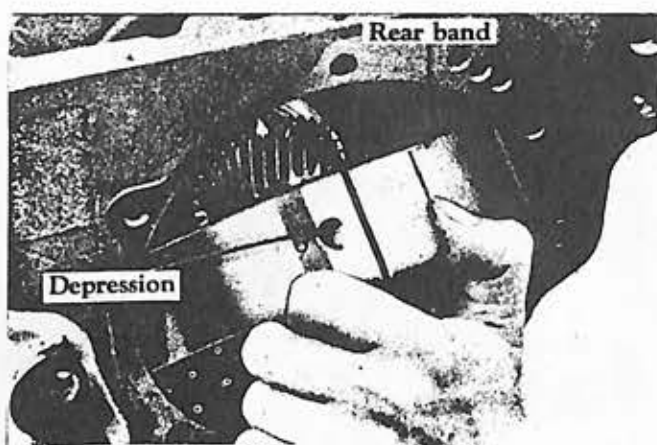

Fig. 53

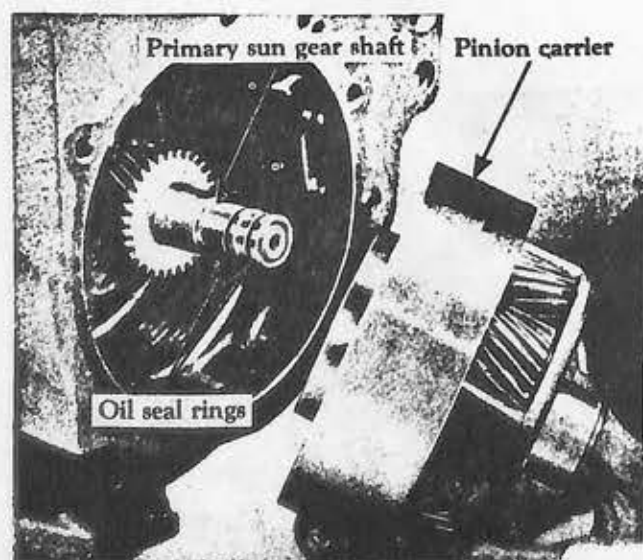

Fig. 51

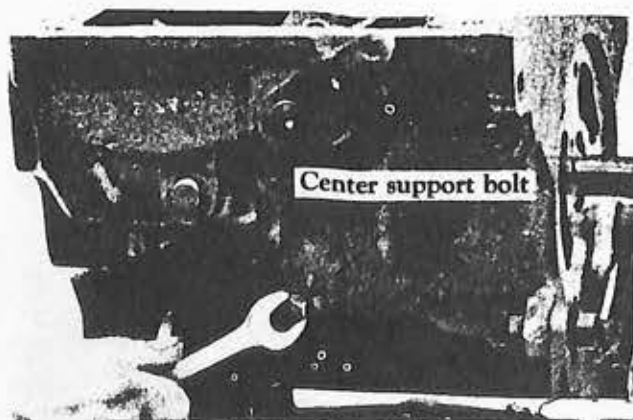

Fig. 54

2. Squeeze the ends of the band together, tilt the band to the rear, then remove the band from the case (Fig. 53).

3. Remove the two center support outer bolts (one each side) Fig. 54) from the transmission case.

4. Exert sufficient pressure on the end of the turbine shaft to hold the clutch units together, then remove the center support, front and rear clutch assemblies as a unit (Fig. 55). **CAUTION:** Hold the clutch assemblies together.

5. Install the clutch assemblies in the holders (Fig. 56).

M. Front Clutch (From Primary Sun Gear Shaft):

1. Remove the thrust washer from the turbine shaft (Fig. 56).

2. Remove the front band from the transmission case (Fig. 57).

3. Lift the front clutch assembly from the primary sun gear shaft (Fig. 58).

**CAUTION:** Do not rock the assembly while lifting to prevent damage to the oil seal rings.

4. Remove the bronze and steel thrust washer from the primary sun gear shaft (Fig. 59).

5. Remove the front clutch oil seal rings from the primary sun gear shaft (Fig. 60). **CAUTION:** Do not break the oil seal rings.

N. Rear Clutch (From Primary Sun Gear Shaft):

1. Lift the rear clutch assembly from the primary sun gear shaft (Fig. 61).

**CAUTION:** Do not rock the assembly while lifting to prevent damage to the oil seal rings.

2. Remove the rear clutch oil seal rings from the primary sun gear shaft (Fig. 62). **CAUTION:** Do not break the oil seal rings.

3. Remove the primary sun gear front thrust washer (Fig. 63).

#### GENERAL INSPECTION

The inspection procedures given in this section cover the oil distributor and a sleeve, pinion carrier, output shaft and transmission extension housing. Fig. 64 shows the relative positions of the output shaft, pinion carrier, oil distributor and sleeve.

#### OUTPUT SHAFT AND PRIMARY SUN GEAR SHAFT

Inspect the thrust surfaces and journals for scores. Inspect the internal gear for broken or worn teeth. Inspect the distributor sleeve for scores or leakage. Check the ring grooves for burrs. Inspect the keyway and drive ball pocket for wear and the splines for burrs or wear. Check the internal parking gear teeth for damage and the speedometer drive gear for burrs. The output shaft is a two-piece assembly and is serviced separately.

Inspect the primary sun gear and shaft as follows: Inspect the sun gear for broken or worn teeth. Inspect all thrust surfaces and journals for scores. Check all fluid passages (Fig. 65) for obstructions and leakage. Inspect the seal ring grooves for burrs. Inspect the sun gear shaft splines for burrs and wear. Inspect the front clutch lubrication valve for free movement.

#### DISTRIBUTOR & SLEEVE

Inspect the distributor sleeve bore for scores or excessive ring wear. Check the fluid passages for obstructions. Inspect the distributor mating surfaces for burrs and flatness.

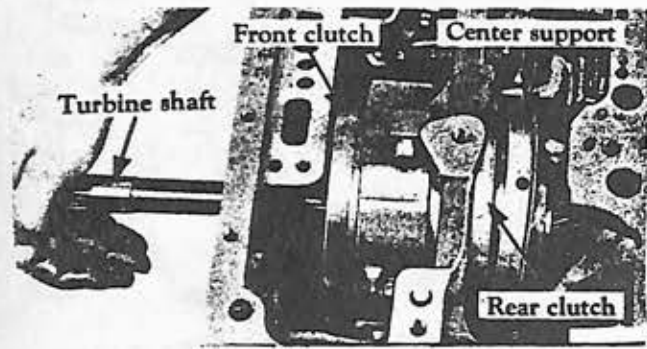

Fig. 55

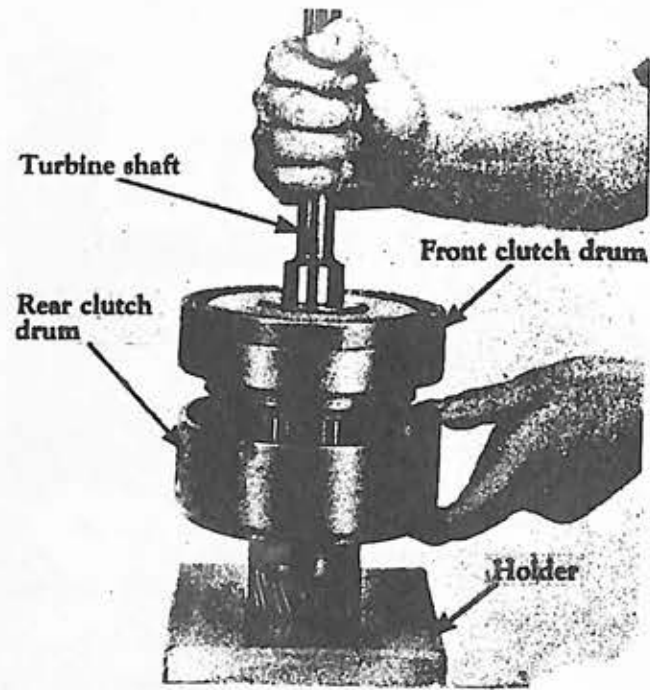

Fig. 58

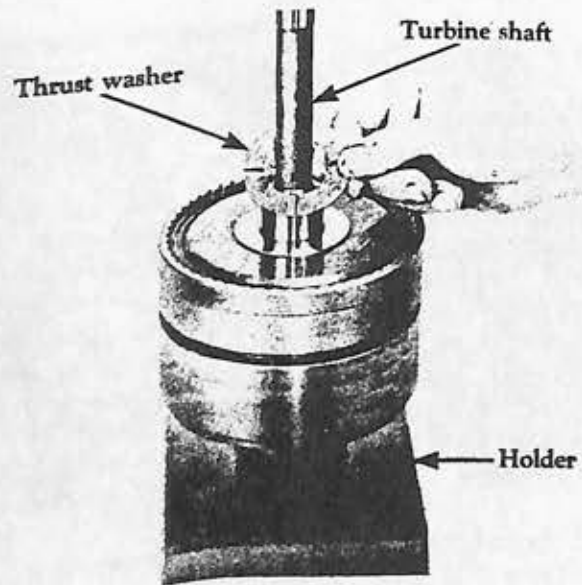

Fig. 56

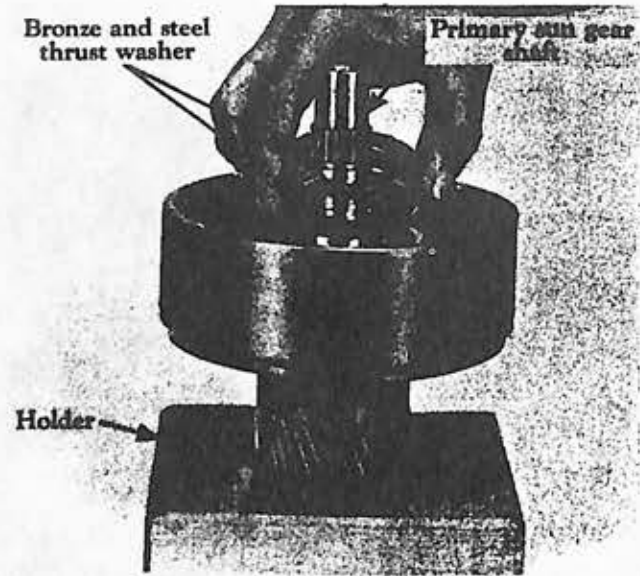

Fig. 59

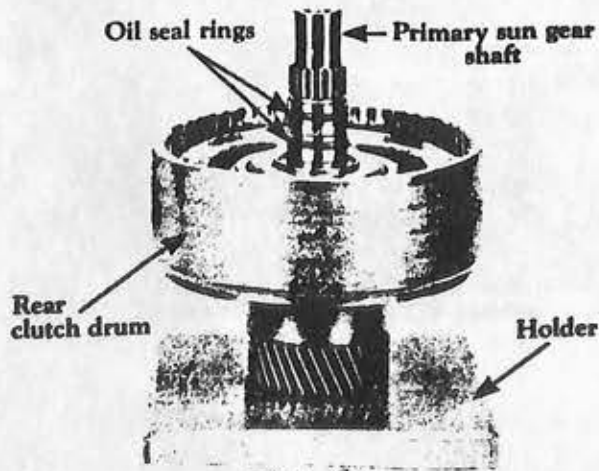

Fig. 60

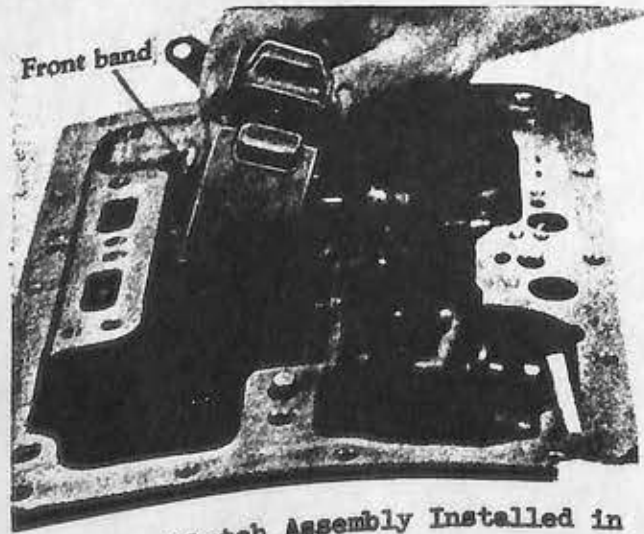

Fig. 57- Clutch Assembly Installed in Holder

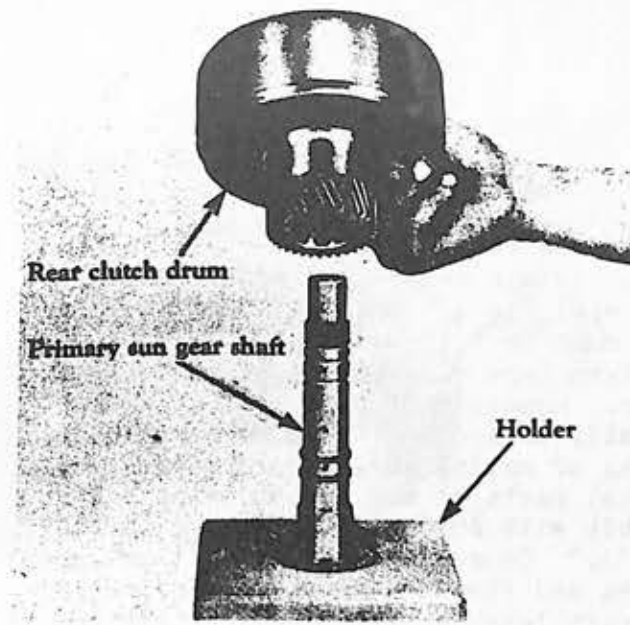

Fig. 61

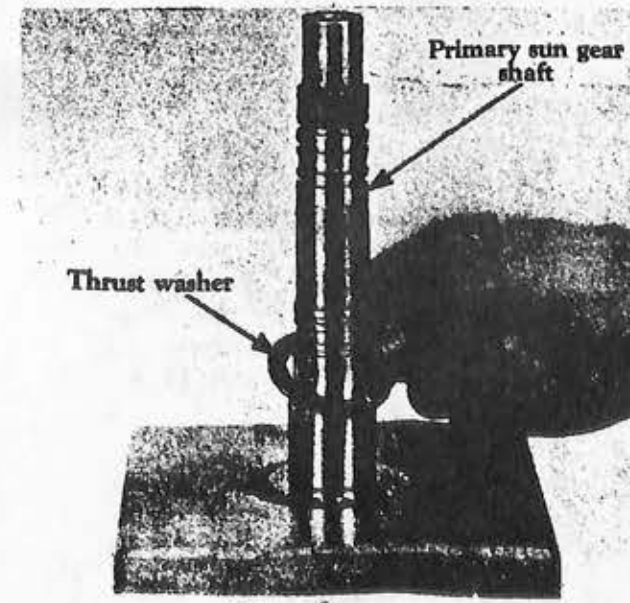
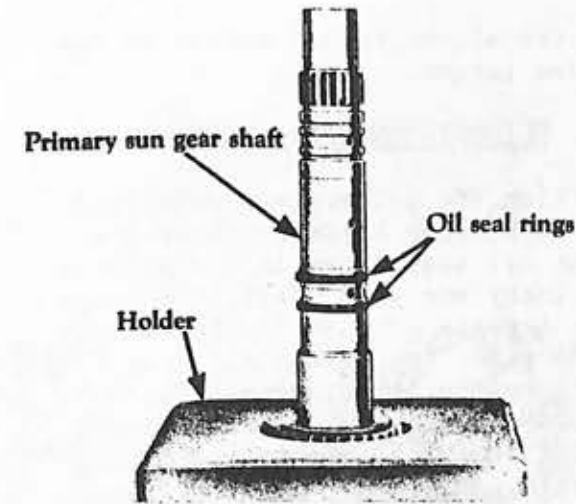

Fig. 63

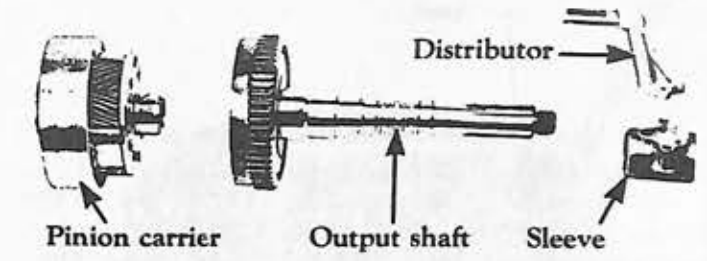

Fig. 64- Carrier, Output Shaft, and Distributor Assemblies.

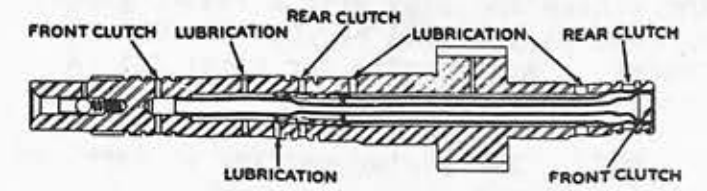

Fig. 65- Lubrication and Fluid Passages of Primary Sun Gear Shaft.

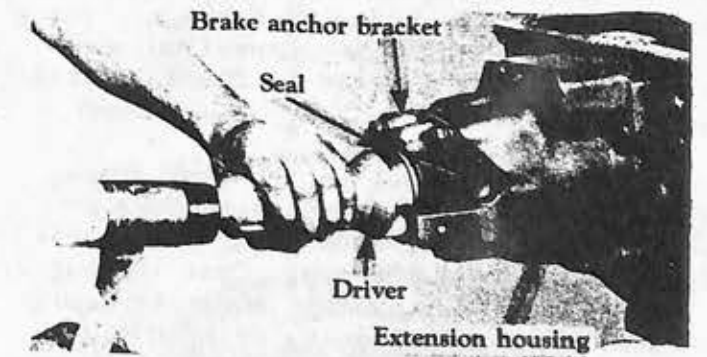

Fig. 66

Inspect the distributor passages for obstructions. Inspect the distributor sleeve mating surface for burrs and flatness. Check the fit of the fluid tubes in the distributor. NOTE: Make sure the spacer is on the center tube.

#### PINION CARRIER

Inspect the servo band surface, inner and outer bushings, and thrust surfaces for scores. Inspect the pinions for broken or worn teeth. Check for free movement of the pinions on their shafts. Check the pinion end play with a feeler gauge. The end play should be .010 to .020 inch. Inspect pinion shafts for tight fit in the carrier.

NOTE: The pinion carrier is serviced as an assembly.

#### EXTENSION HOUSING

Inspect the housing for cracks. Inspect the bearing for scores and the gasket surfaces for burrs or warpage. Check for leakage around the inspection cover and gasket. If leakage is found, install a new gasket.

Inspect the seal in the rear brake anchor bracket for hardness, cracks or wear. If the seal shows wear or deterioration, replace the seal. Coat the outer diameter of a new seal with non-hardening sealer, then position the seal in the brake anchor bracket counterbore with the lip side out. Drive the seal into place, using driver as shown in Fig. 66 until it is firmly seated in the counterbore.

#### REPAIR AND ASSEMBLY OF SUB-ASSEMBLIES

The following repair procedure includes the disassembly, inspection, and assembly of the sub-assemblies removed from the transmission case.

The proper installation of the various thrust washers used in the transmission is one of the most important steps in transmission build-up.

#### GENERAL INSTRUCTIONS

During the repair of the sub-assemblies, certain general instructions, which apply to all units of the transmission, must be followed. These instructions are given here to avoid unnecessary repetition. Handle all transmission parts carefully to avoid nicking or burring the bearing or mating surfaces. Lubricate all internal parts of the transmission before assembly with AUTOMATIC TRANSMISSION FLUID, TYPE "A." Do not use any other lubricants. Gaskets and thrust washers may be coated with petroleum jelly in order to aid the assembler. Always install new gaskets when assembling the transmissions or units of the transmission.

Tighten all bolts and screws to the recommended torque.

#### PRIMARY SUN GEAR SHAFT

Position the primary sun gear shaft in the clutch bench holder. Check the fit of the oil seal rings in the grooves of the primary sun gear shaft. The rings should center the grooves freely without bind. Check the fit of the oil seal rings in the respective bores. A clearance of .002 - .009 inches should exist between the ends of the rings. Install the rings on the shaft, then check for free movement in the grooves.

#### REAR CLUTCH

Position the rear clutch spring compressor, on the rear clutch (Fig. 68). Compress the spring and remove the snap ring. CAUTION: Guide the spring retainer while releasing to prevent the retainer from interfering with the snap ring groove. Remove the retainer and release spring as shown in Fig. 69. Remove the clutch pressure plate snap ring (Fig. 70), then remove the pressure plate from the drum (Fig. 71). Remove the four bronze and four steel plates from the drum (Fig. 72).

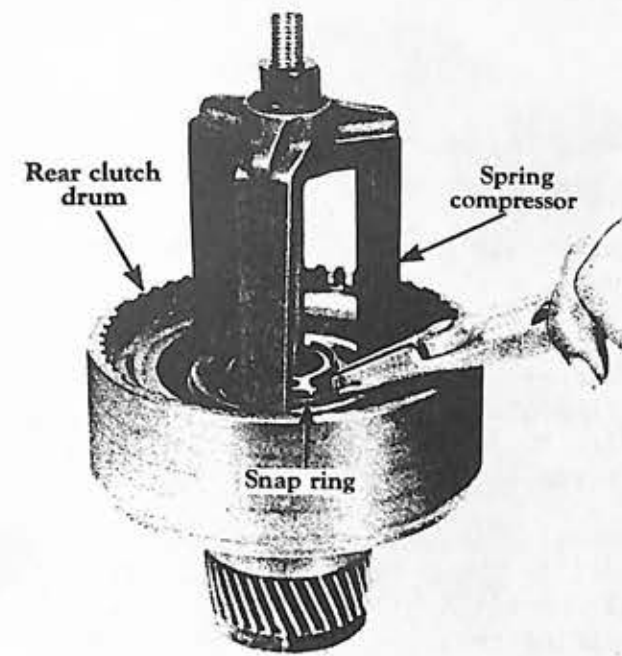

Fig. 68

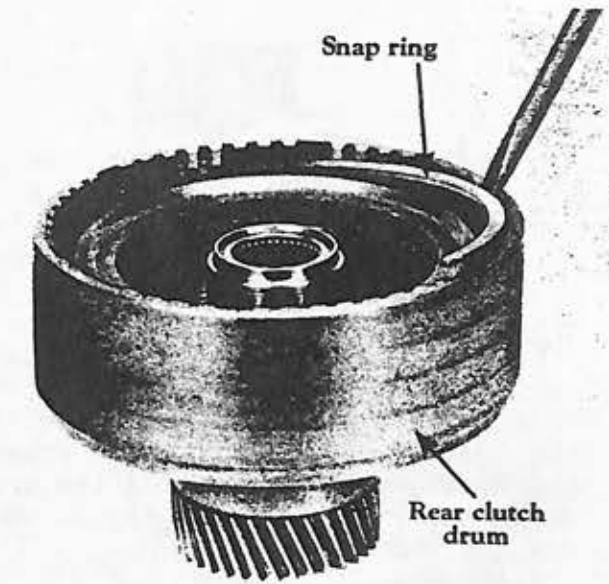

Fig. 70

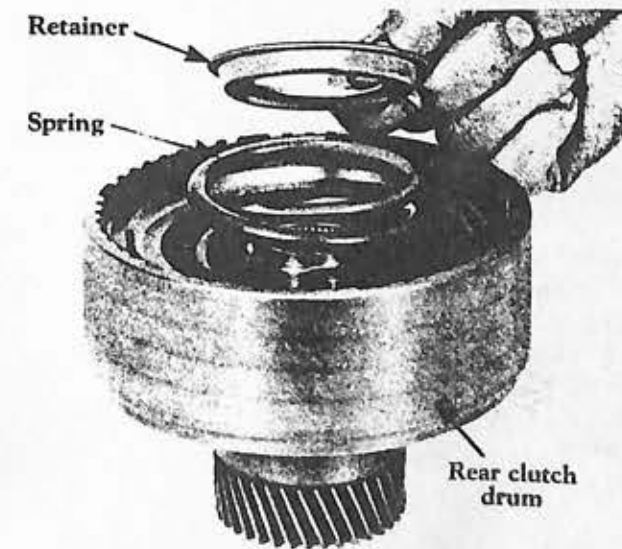

Fig. 69

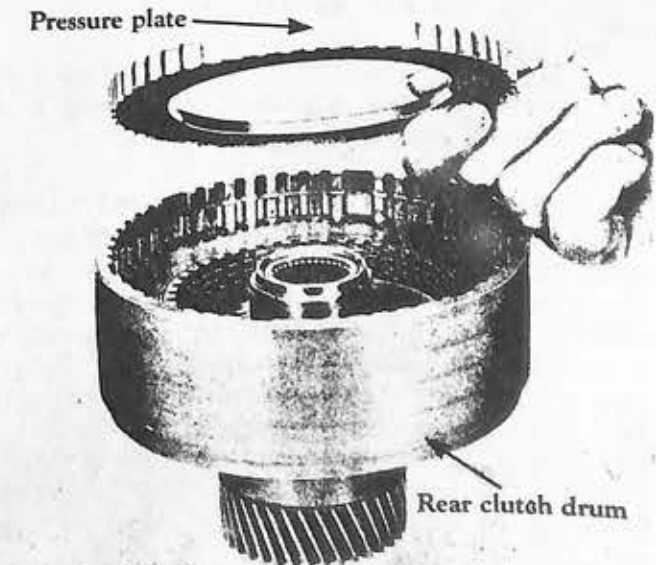

Fig. 71

Position the rear clutch on the primary sun gear shaft as shown in Fig. 73. Place an air hose nozzle on one of the holes in the shaft and hold one finger over the other hole, then force the clutch piston out of the clutch drum with air pressure (Fig. 73). Remove the clutch piston inner "O" ring from the hub of the clutch drum (Fig. 74). Remove the clutch piston outer seal ring from the groove in the piston (Fig. 75). Inspect the drum band surface, bushing, and thrust surfaces for scores.

Minor scores may be removed with crocus cloth. Badly scored parts must be replaced.

Inspect the needle bearing for worn or loose rollers. Inspect the gear teeth for burrs or wear. Inspect the clutch piston bore and the piston inner and outer bearing surfaces for scores. Check the fluid passages for obstructions. All fluid passages must be clean and free of obstruction. Inspect the clutch plates for scores, and check the plates for fit on the clutch hub serrations. Replace all plates that are badly scored or do not fit freely in the hub serrations.

**CAUTION:** The front clutch plates differ from the rear clutch plates and are not interchangeable.

Check the coning of the steel plates. Position the plates on a flat surface, then check the coning with a feeler gauge. The plates are coned to .010 inch clearance (Fig. 76). Discard any plates that are not coned at least .010 inch. Inspect the clutch pressure plates for scores on the clutch plate bearing surfaces. Replace the plate if deeply scored. Check the clutch release spring for distortion and discard if badly bent. Lubricate all parts to aid in assembly. Install a new clutch piston inner "O" ring in the groove in the drum (Fig. 74). Install a new outer seal ring on the piston (Fig. 75). Install the piston in the clutch drum (Fig. 77). Install the four steel and the four bronze clutch plates alternately, starting with

a steel plate, convex side up (Fig. 72).

**NOTE:** Lubricate the plates as they are installed.

Install the clutch pressure plates with the bearing surface down (Fig. 71). Install the clutch pressure plate snap ring (Fig. 70). Make sure the snap ring is fully sealed in the groove.

Install the clutch release spring, then position the retainer on the spring (Fig. 69). Position the clutch assembly on the spring retainer, using the spring compressor, as shown in Fig. 68. Compress the clutch spring, then install the snap ring.

**CAUTION:** While compressing the spring, guide the retainer to avoid interference of the retainer with the snap ring groove. Make sure the snap ring is fully seated in the grooves.

Install the bronze thrust washer on the primary sun gear shaft (Fig. 63). Install the rear clutch oil seal rings on the primary sun gear shaft (Fig. 62).

Lubricate all parts to aid in assembly. Install the rear clutch assembly on the primary sun gear shaft (Fig. 61). **CAUTION:** Center the oil seal rings on the primary sun gear shaft to prevent breakage.

Install the steel and bronze thrust washer on the primary sun gear shaft in the order shown (Fig. 59). Install the front clutch (two) oil seal rings in the grooves of the primary sun gear shaft (Fig. 60). Check the oil seal rings for free movement in the grooves and in their respective bores.

#### FRONT CLUTCH

Remove the clutch turbine shaft snap ring with a screwdriver (Fig. 78). Then remove the turbine shaft and thrust washer from the thrust surface of the clutch hub, then lift the hub straight up to remove the hub from the clutch drum (Fig. 80).

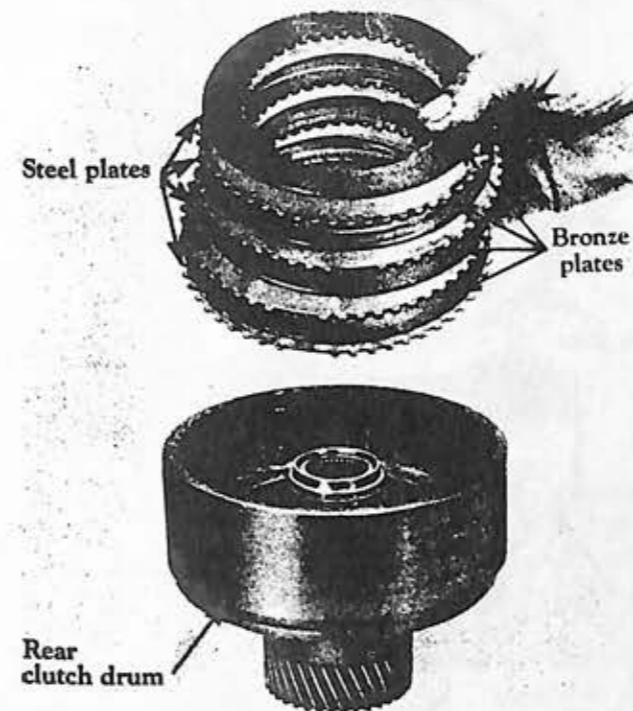

Fig. 72

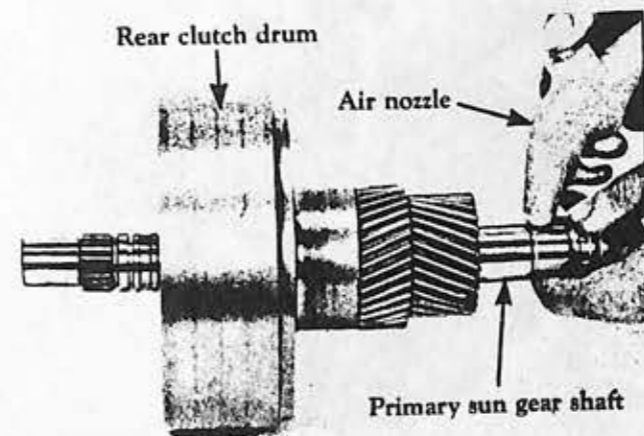

Fig. 73

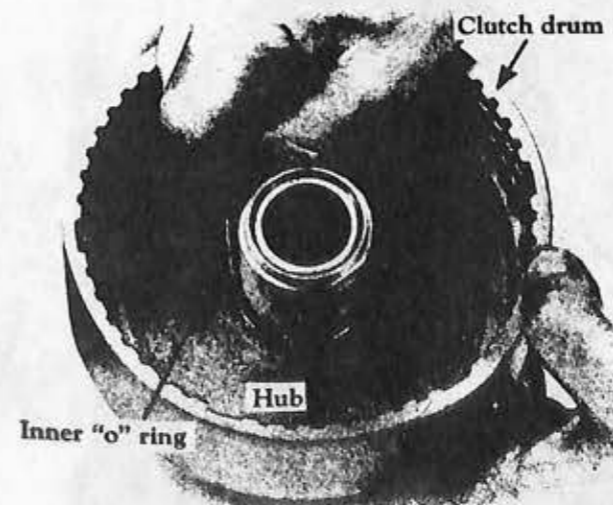

Fig. 74

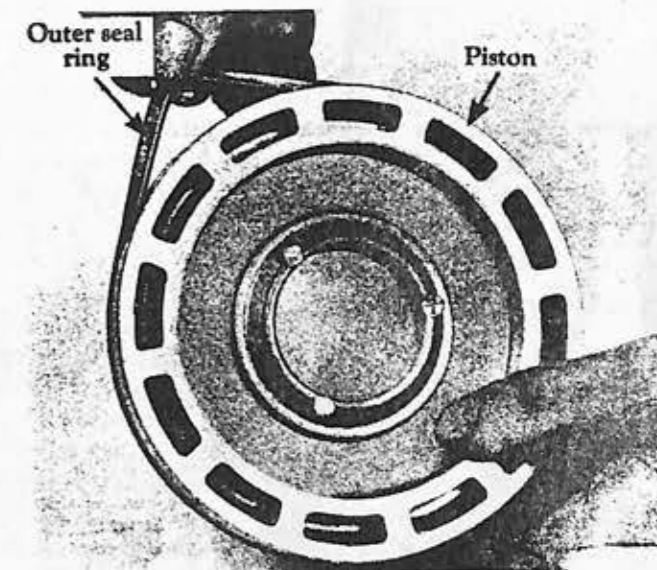

Fig. 75

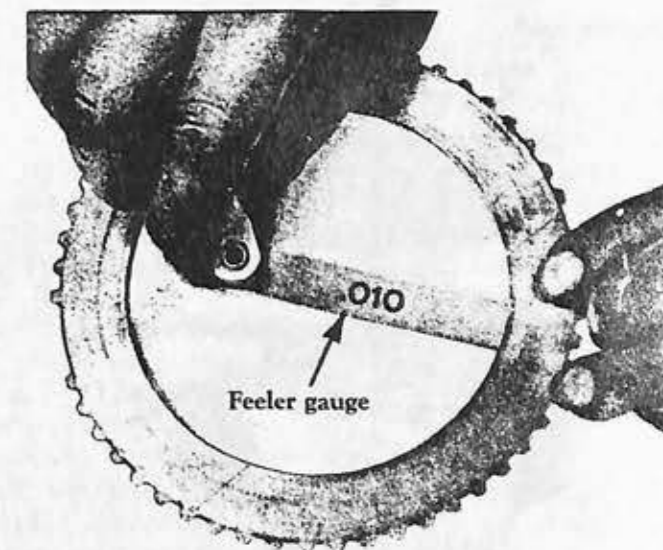

Fig. 76

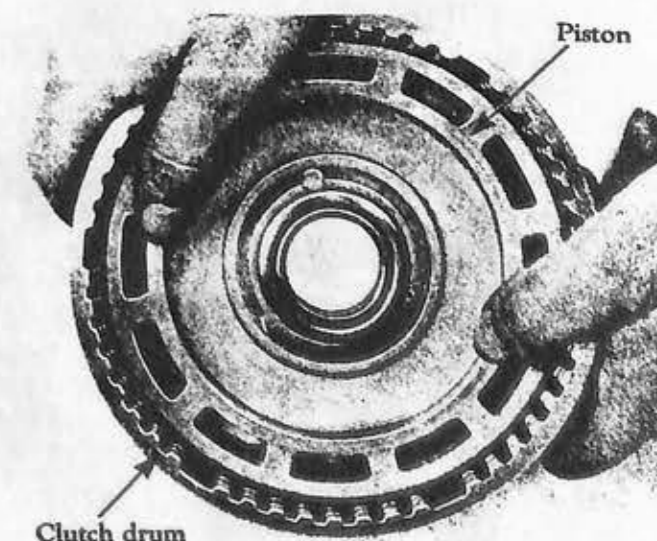

Fig. 77



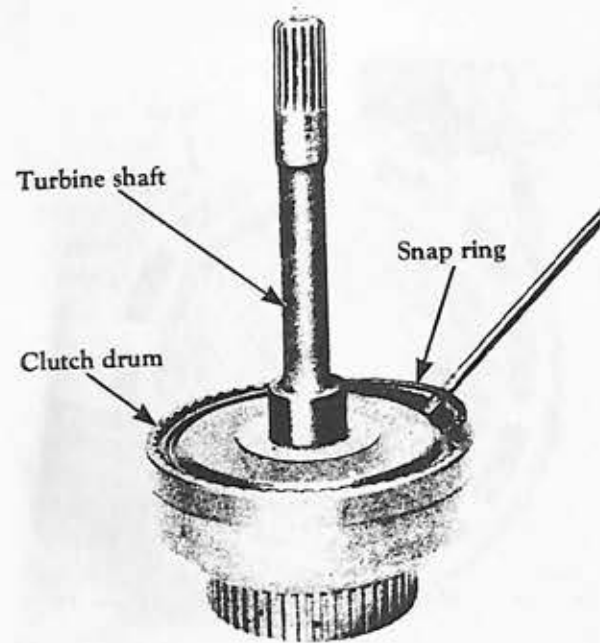

Fig. 78

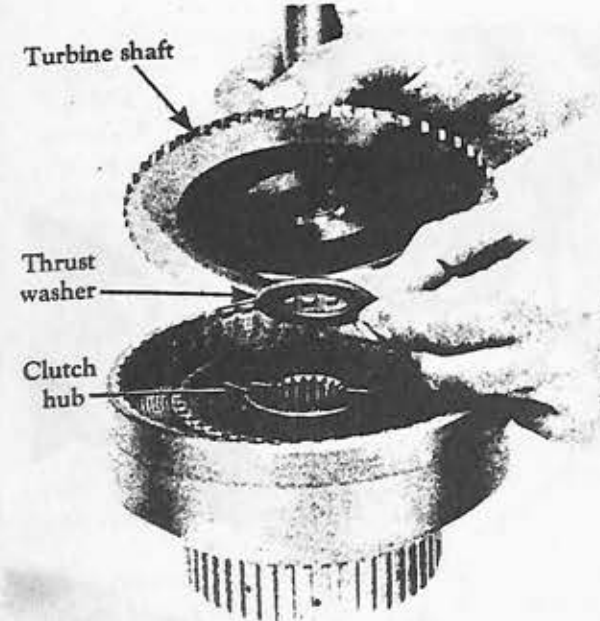

Fig. 79

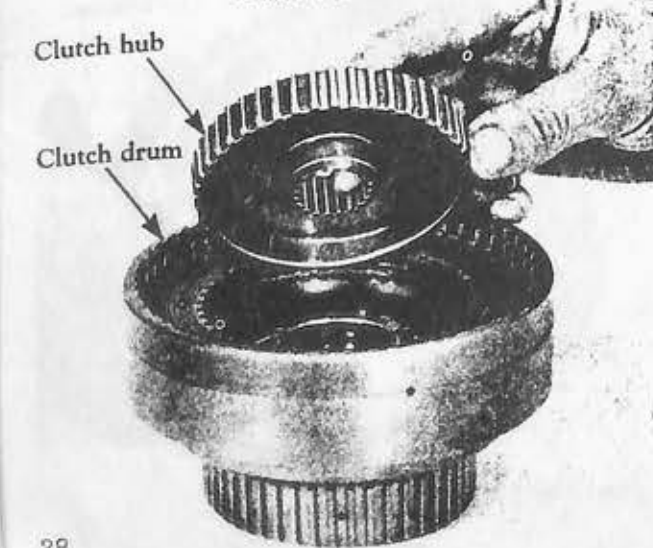

Fig. 80

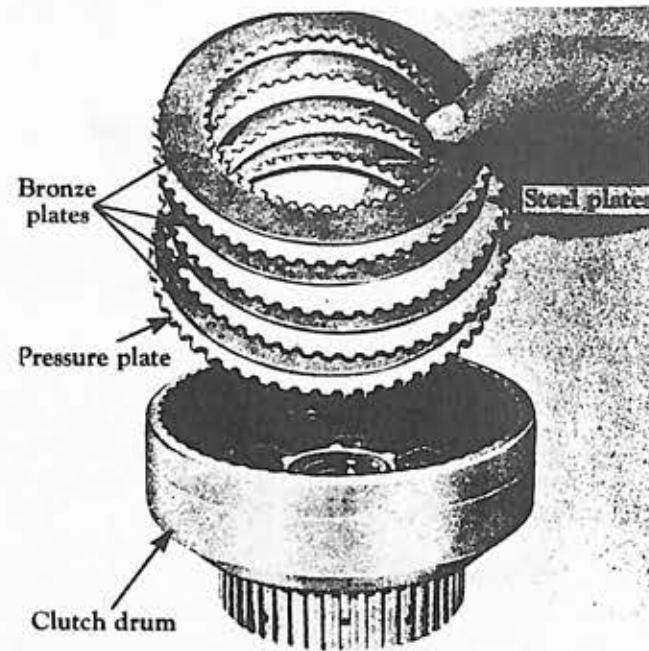

Fig. 81

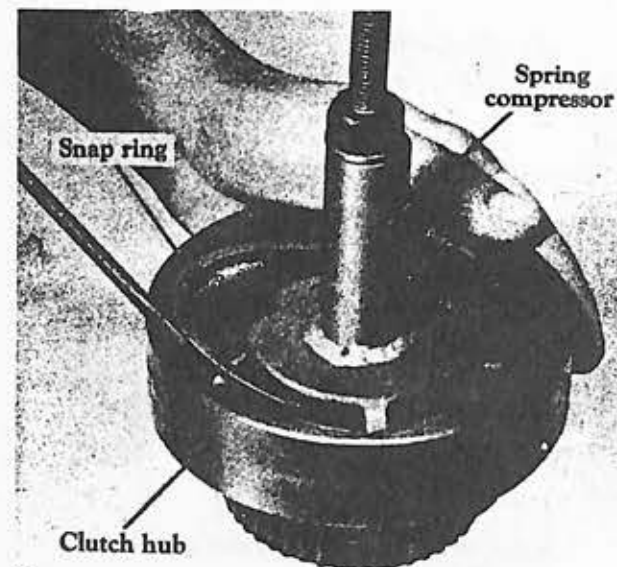

Fig. 82-Using Clutch Spring Compressor

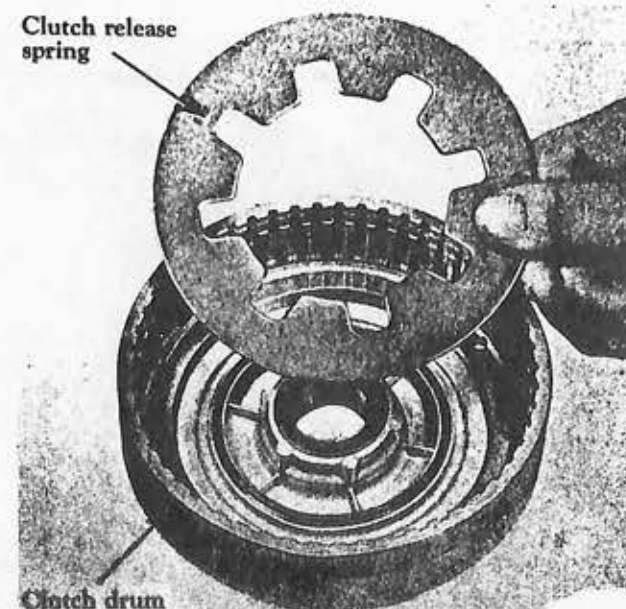

Fig. 83

Remove the four bronze and the three steel clutch plates, then remove the pressure plate from the clutch drum (Fig. 81). Place the front clutch release spring compressor, on the release spring, then compress the release spring until the release spring snap ring can be removed (Fig. 82). Remove the clutch release spring from the clutch drum (Fig. 83).

Place an air hose nozzle against the clutch apply hole in the front clutch housing and force the piston out of the housing with air (Fig. 84). Remove the piston inner "O" ring from the clutch housing as shown in Fig. 85. Remove the piston outer seal from the groove in the piston (Fig. 86).

Inspect the clutch cylinder thrust surfaces, piston bore and clutch plate serrations for scores or burrs. Minor scores or burrs may be removed with crocus cloth. Replace the clutch cylinder if it is badly scored or damaged. Check the fluid passage in the clutch cylinder for any obstructions. Clean out all fluid passages. Inspect the clutch piston for scores and replace if necessary. Check the clutch release spring for distortion and cracks. Replace the spring if it is distorted or cracked.

Inspect the bronze and steel clutch plates and the pressure plate for scored bearing surfaces. Replace all parts that are deeply scored. Check the clutch plates for flatness and for fit on the clutch hub serrations. Discard any plates that do not slide freely on the serrations or that are flat. **CAUTION:** The front clutch plates differ from the rear clutch plates and are not interchangeable.

Check the clutch hub thrust surfaces for scores and the clutch hub splines for wear. Check the bronze thrust washers for scores. Inspect the turbine shaft bearing surfaces for scores. Check the splines on the turbine shaft for wear and replace the shaft if excessively worn. If the bushing is deeply scored, replace the turbine shaft and bushing assembly.

Lubricate all parts with Automatic Transmission Fluid, Type "A." Install a new piston inner "O" ring in the clutch cylinder as shown in Fig. 85. Install a new piston outer seal ring in the groove in the piston as shown in Fig. 86. Install the piston in the clutch housing (Fig. 87). **NOTE:** Make sure the steel bearing ring is in place on the piston.

Position the release spring in the clutch cylinder with the concave side up (Fig. 83). Place the release spring compressor on the spring, compress the release spring, then install the snap ring as shown in Fig. 82. **NOTE: MAKE SURE THE SNAP RING IS FULLY SEATED IN THE GROOVE.**

Install the front clutch oil seal rings on the primary sun gear shaft (Fig. 60). Install the front clutch housing on the primary sun gear shaft by rotating the clutch units to mesh the rear clutch plates with the serrations on the front clutch cylinder (Fig. 88). **CAUTION:** Do not break the oil seal rings.

Install the clutch hub in the clutch cylinder with the deep counterbore down (Fig. 89). Install the thrust washer on the clutch hub (Fig. 90). Install the pressure plate in the clutch cylinder with the bearing surfaces up (Fig. 91). Install the four bronze and three steel clutch plates alternately, starting with a bronze plate (Fig. 92). Lubricate the plates as they are installed.

Install the turbine shaft in the clutch cylinder (Fig. 93), then install the snap ring (Fig. 94). **NOTE:** Make sure the snap ring is fully seated in the groove. Install the thrust washer on the turbine shaft (Fig. 56).

#### FRONT PUMP

Remove the stator support attaching screws and lockwashers (Fig. 95), then remove the stator support. Mark the top surfaces of the pump gears with prussian blue to assure correct assembly (Fig. 96).

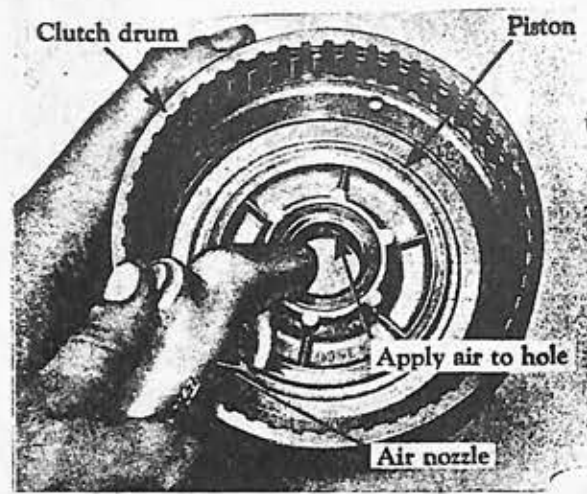

Fig. 84

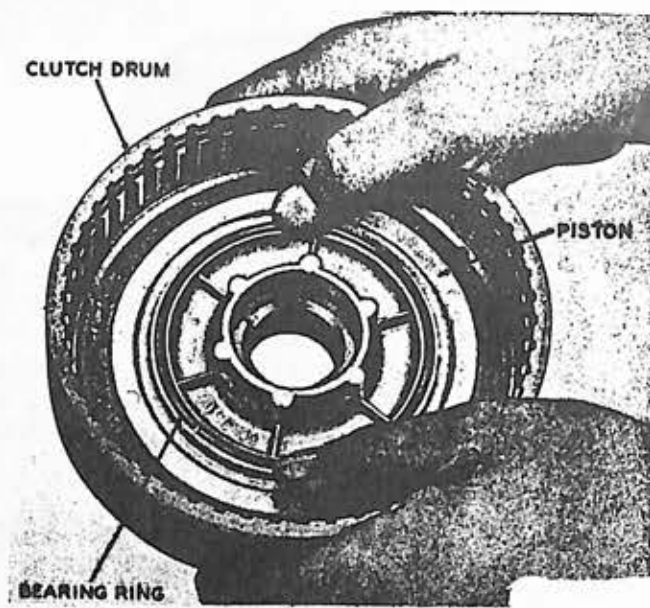

Fig. 87

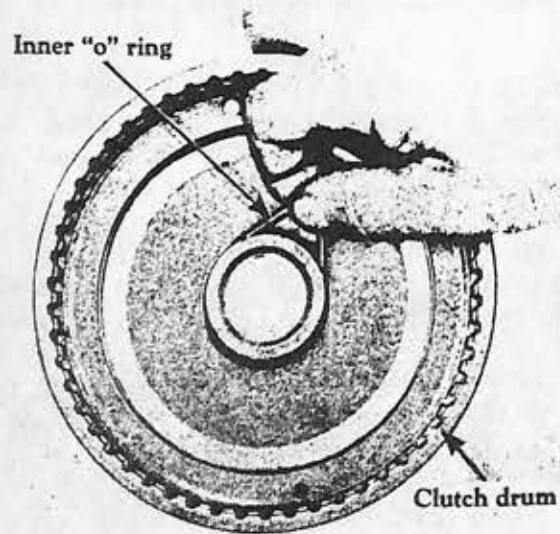

Fig. 85

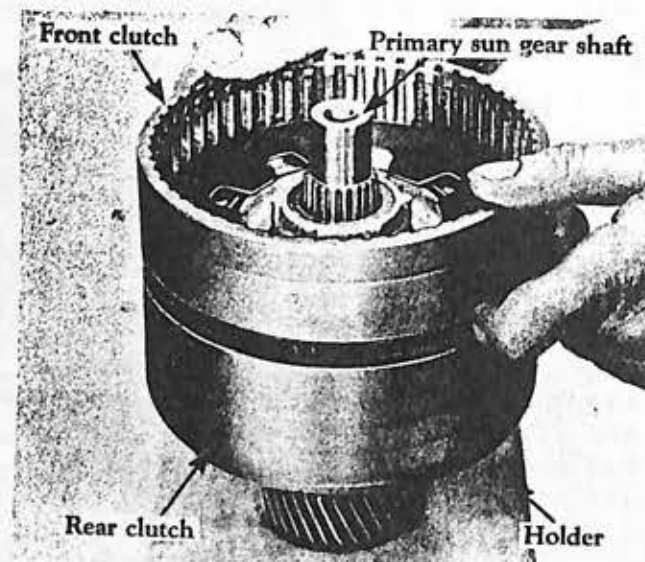

Fig. 88

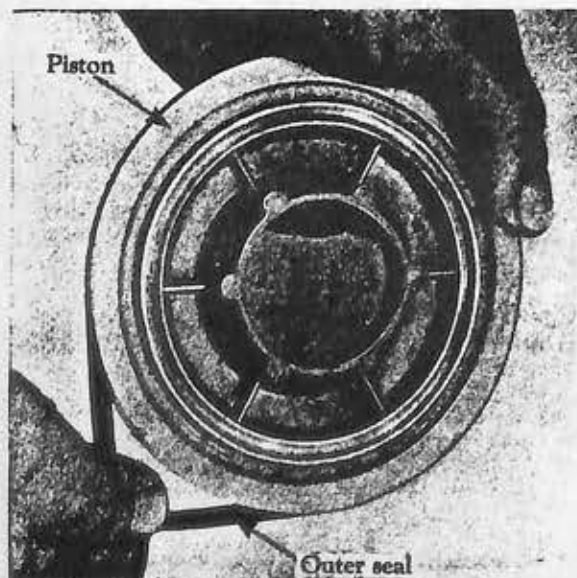

Fig. 86

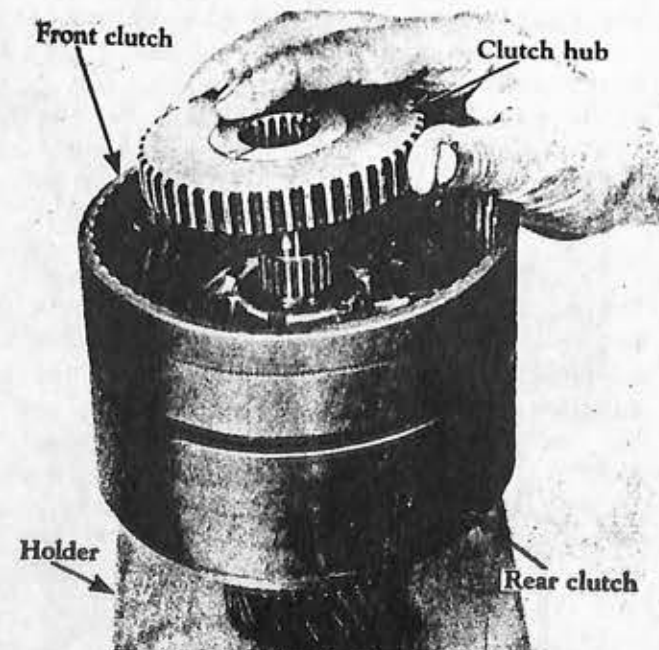

Fig. 89 Installing Clutch Hub. Deep Counterbore down.

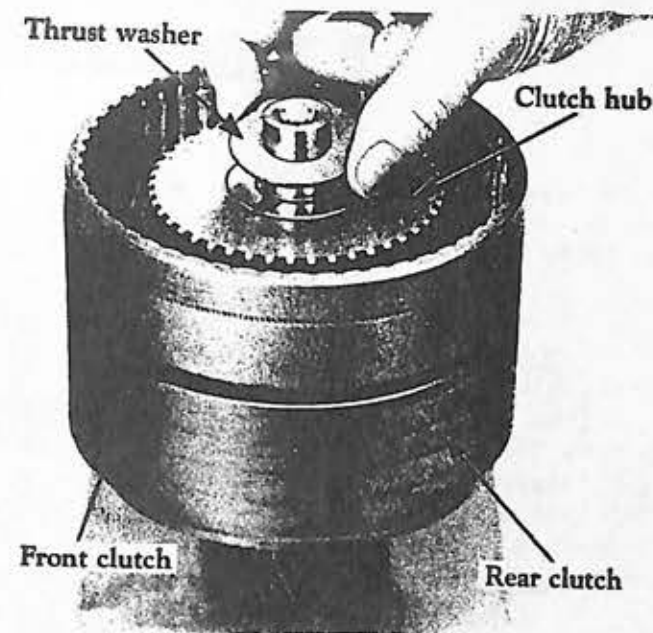

Fig. 90

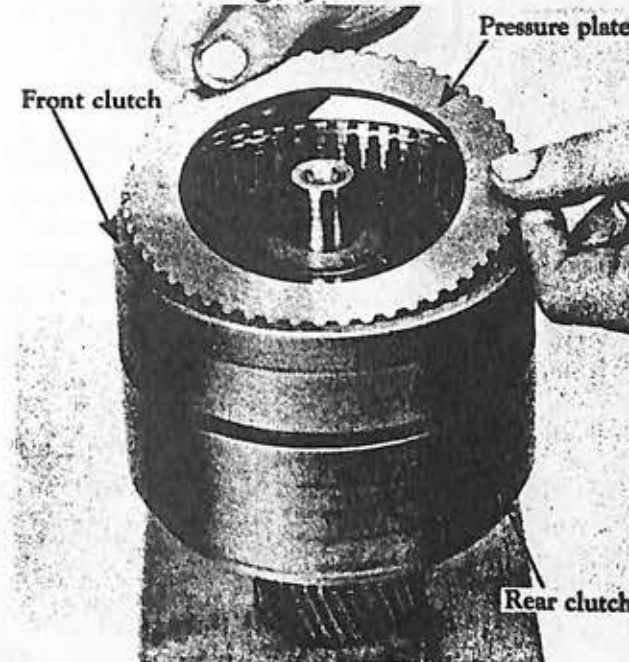

Fig. 91-Installing Pressure Plate. Bearing Surfaces Up.

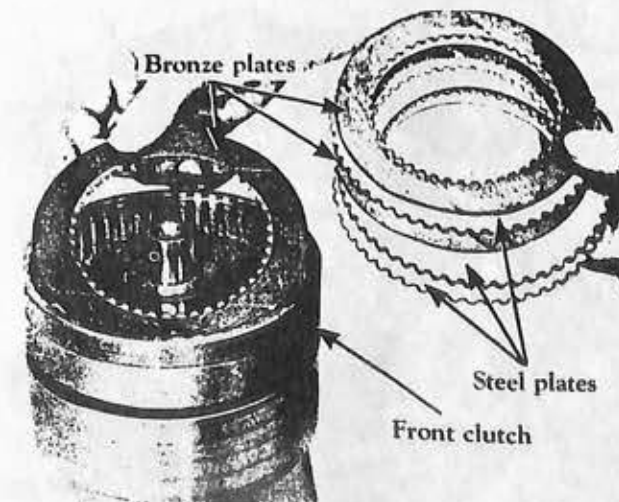

Fig. 92

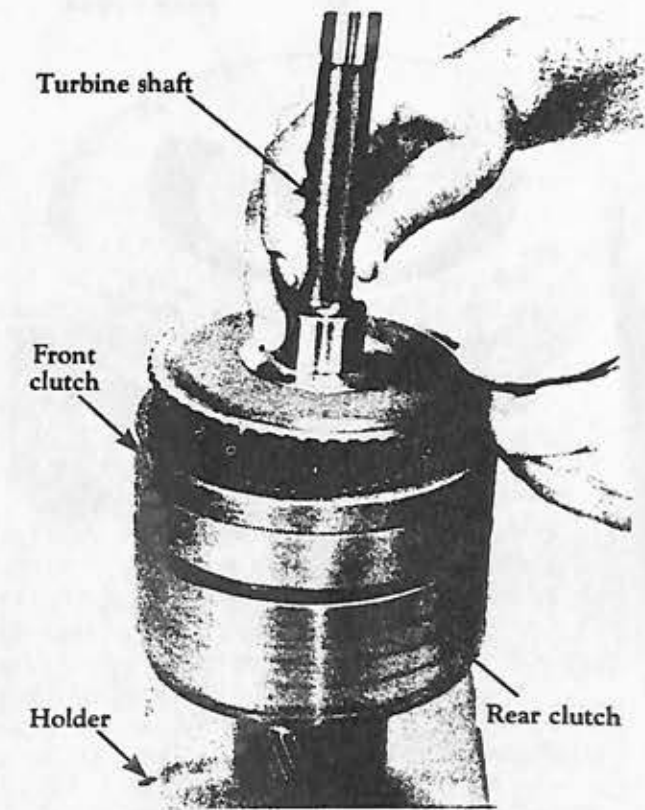

Fig. 93

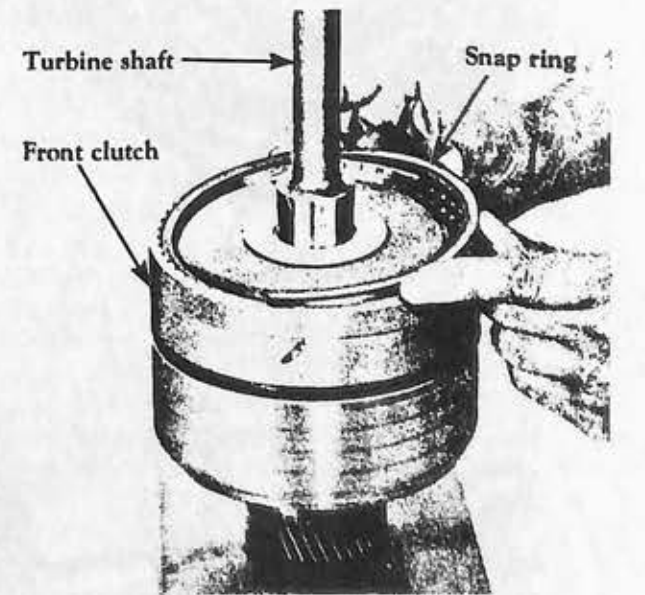

Fig. 94

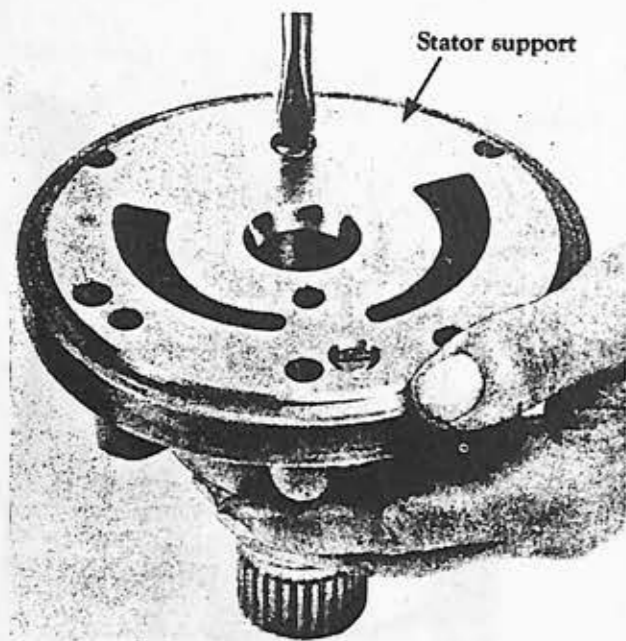

Fig. 95

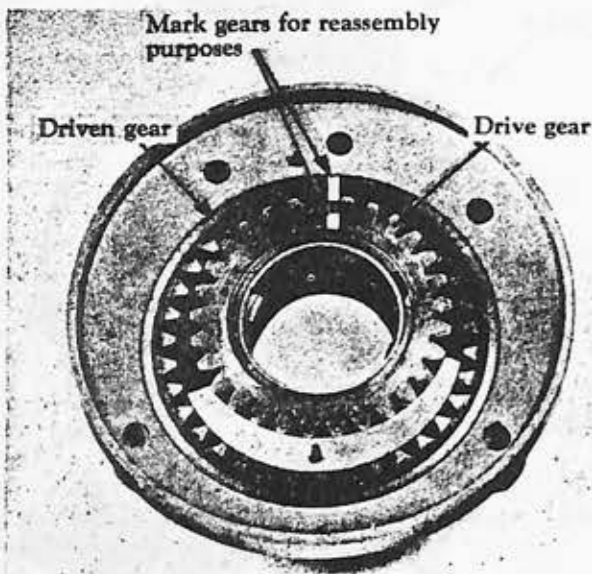

Fig. 96

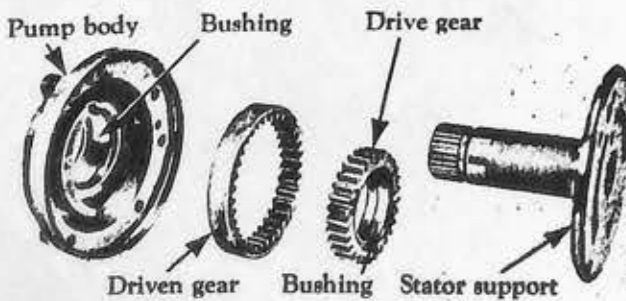

Fig. 97-Front Pump Disassembled

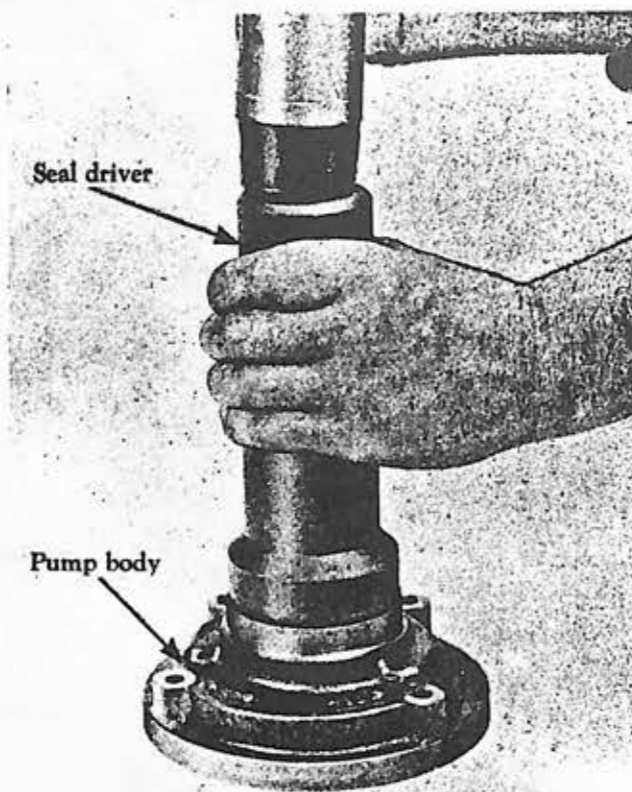

Fig. 98-Installing Seal in Pump Body using Tool.

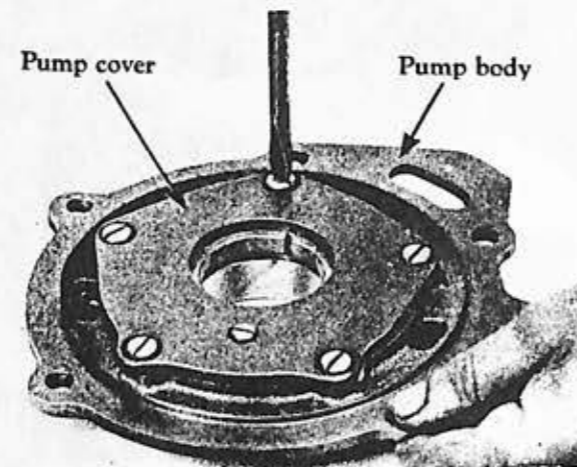

Fig. 99

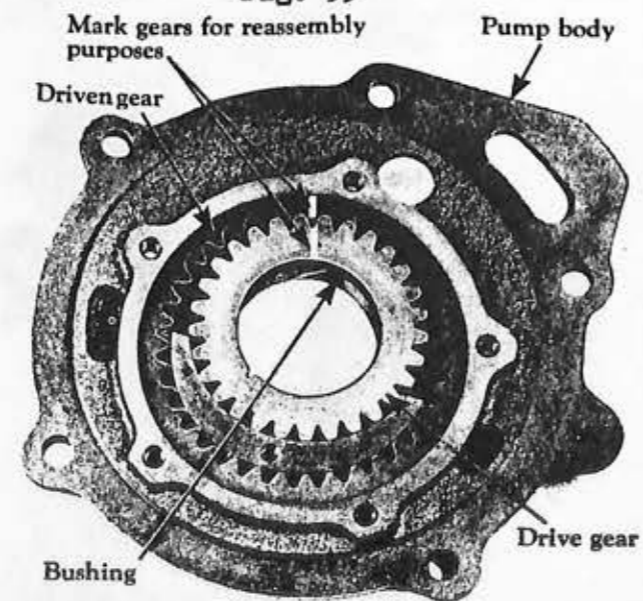

Fig. 100

Remove the drive and driven gears from the pump body. Refer to Fig. 97 for a disassembled view of the front pump. Inspect the pump body bushing, drive gear bushing, gear pockets, and crescent for scores. Inspect the mating surfaces of the pump body and cover for burrs. Inspect the drive and driven gear bearing surfaces for scores and check the gear teeth for burrs. Inspect the stator support bushing for scores. Check the stator support splines for burrs and wear. Check all fluid passages for obstructions.

If any pump parts other than the stator support are found defective, replace the pump as a unit. Minor burrs and scores may be removed with crocus cloth. The stator support is serviced separately. Pry the oil seal from the front pump body and discard. Clean the pump body counterbore, then inspect the bore for rough spots. Smooth up the counterbore with crocus cloth. Coat the outer diameter of a new seal with non-hardening sealer, then position the seal into the pump body with driver, until the seal is firmly seated (Fig. 98).

Place the pump driven gear in the pump body with the marks on the gear facing upward (Fig. 96). Install the drive gear in the pump body, aligning the marks together. Install the stator support attaching screws and lockwashers. Check the pump for free movement.

#### REAR PUMP

Remove the screws and lockwashers which secure the pump cover to the pump body (Fig. 99), then remove the cover. Mark the top face of the pump drive and driven gears with prussian blue to assure correct installation of gears upon reassembly (Fig. 100). CAUTION: Do not scratch the pump gears. Fig. 101 illustrates an exploded view of the rear pump. Remove the drive and driven gears from the pump body. Inspect the gear pockets and crescent of the pump body for scores or pitting.

Inspect the bushing and the drive and driven gear bearing surfaces for scores. Check all fluid passages for obstructions and clean if necessary. Inspect the gear teeth for burrs. Inspect the mating surfaces and gasket surfaces of the pump body and cover for burrs. If any pump parts are defective, replace the pump as a unit. Minor burrs or scores may be removed with crocus cloth.

Place the pump driven gear in the pump body with the mark facing upward. Install the drive gear in the pump body with the mark upward and in alignment with the driven gear marking (Fig. 100). Install the pump cover, attaching screws and lockwashers. Tighten the  $\frac{1}{4}$  inch screws to 50-60 inch-pounds torque and the No. 10-24 screw to 20-30 inch-pounds torque. Check the pump for free movement of the gears.

#### PRESSURE REGULATOR BODY

Remove the valves from the regulator body (Fig. 102). Remove the regulator body cover attaching screws and remove the cover (Fig. 103). Remove the check valve and spring from the separator plate (Fig. 104). Remove the separator plate from the regulator body (Fig. 105).

Wash all parts thoroughly in cleaning solvent and blow dry with compressed air. Inspect the regulator body and cover mating surfaces for burrs. Check all fluid passages for obstructions. Inspect the control pressure and converter pressure valves and bores for burrs and scores. Remove all burrs carefully with crocus cloth. Check free movement of the valves in their respective bores. The valves should fall freely into the bores when the valve and bore are dry. Inspect the valve springs for distortion.

When assembling the parts, avoid damaging them. Position the check valve spring and valve in the regulator cover. Position the separator plate on the regulator cover. Place the regulator

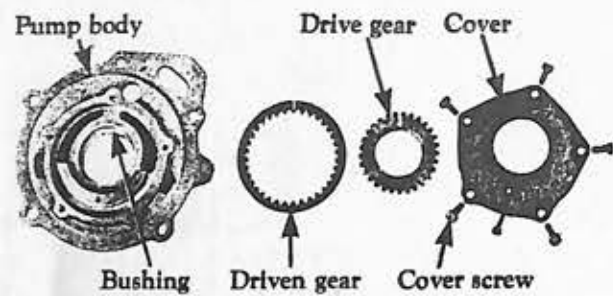

Fig. 101

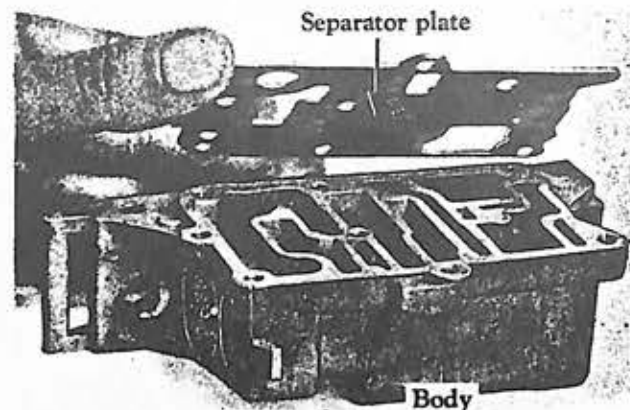

Fig. 105

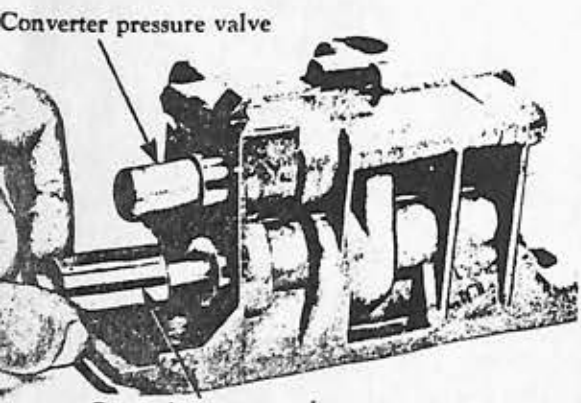

Fig. 102

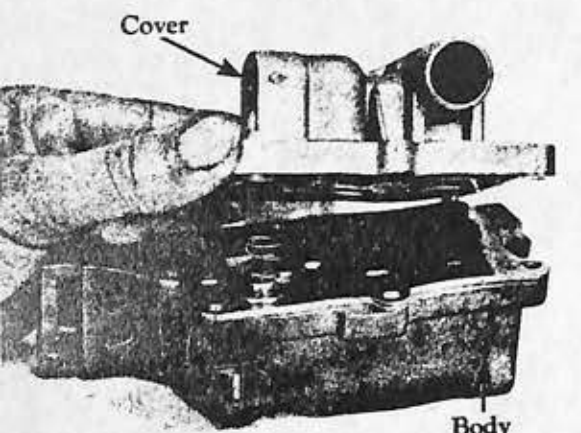

Fig. 103

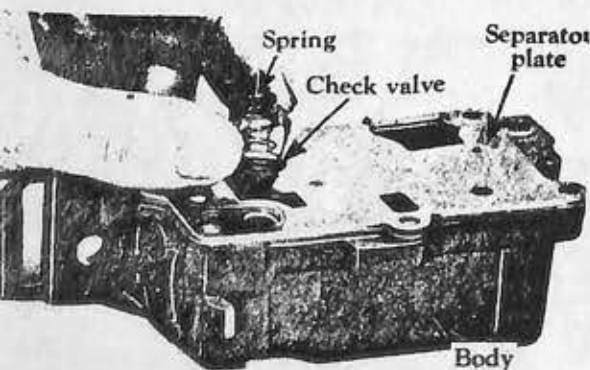

Fig. 104

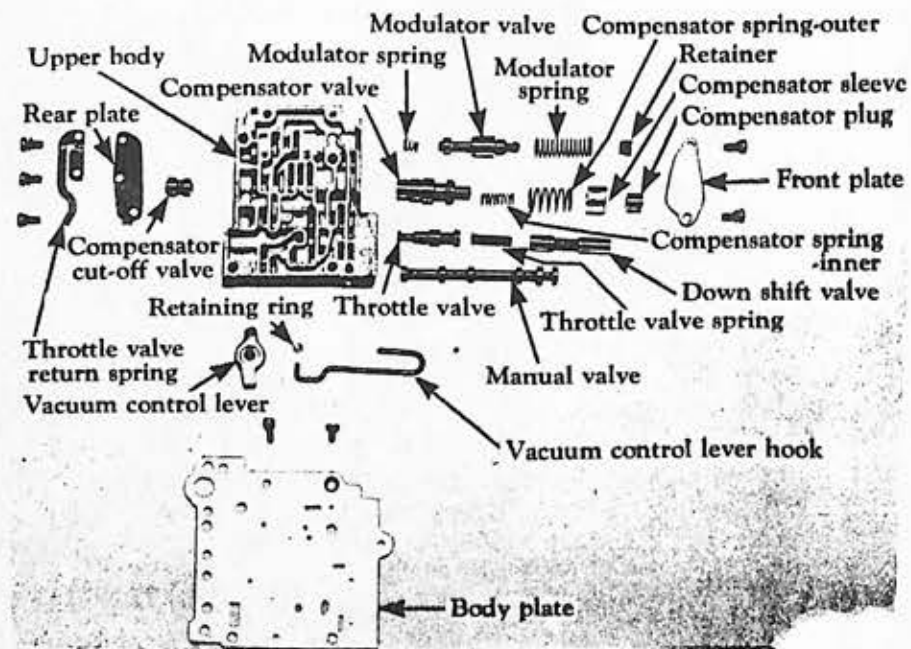

Fig. 106- Upper Control Valve Body

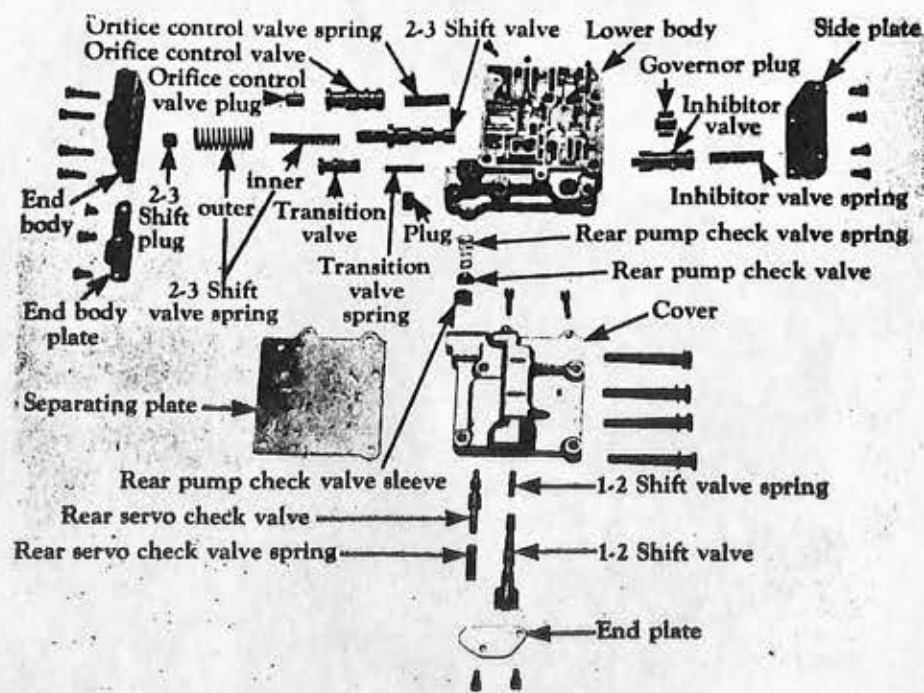

Fig. 107- Lower Control Valve Body and Cover

cover and separator plate on the regulator body, then install the attaching screws. Tighten the screws to 20-30 inch-pounds. Insert the valves in the pressure regulator body.

CONTROL VALVE BODY

During the disassembly of the control valve assembly, avoid damage to the valve parts and keep the valve parts clean. Place the valve assembly on a clean towel while performing the disassembly operation. NOTE: Do not separate the valve bodies until after the valves have been removed.

Remove the manual valve. Remove one screw attaching the separator plate to the lower valve body. Remove the upper body front plate (Fig. 106). NOTE: The plate is spring loaded. Apply pressure to the plate while removing the attaching screws.

Remove the compensator sleeve and plug, then remove the compensator valve outer spring. Remove the compensator valve. Remove the modulator valve retainer, large spring, valve and small spring. Remove the vacuum control lever hook retaining ring and push the downshift valve into its bore to remove the control lever hook. Remove the downshift valve and spring. Remove the two screws which attach the throttle valve return spring to the upper body, then remove the spring. Remove the remaining screw attaching the upper valve body rear plate to the body, then remove the plate. Remove the throttle valve, then the compensator cut-off valve. Remove the lower body side plate (Fig. 107). NOTE: The plate is spring loaded. Apply pressure to the plate while removing the attaching screws.

Remove the low inhibitor valve spring and valve, then remove the governor plug. Remove the end body. NOTE: The end body is spring loaded. Apply pressure to the body while removing the attaching screws. Remove the orifice control valve plug and the 2-3 shift valve plug from the end body. Remove the end body plate.

Remove the 2-3 shift valve outer and inner springs, then remove the shift valve. Remove the orifice control valve and spring. Remove the transition valve and spring. Remove the cover end plate. Remove the 1-2 shift valve and spring, then remove the rear servo check valve spring and valve. Remove the attaching bolts and screws, then separate the bodies.

Remove the valve body plate and separator plate from the upper and lower bodies. Remove the rear pump check valve sleeve, check valve and spring from the lower body. Clean all parts thoroughly in cleaning solvent, then blow dry with compressed air. Inspect all valve and plug bores for scores. Check all fluid passages for obstructions. Inspect the check valve for free movement. Inspect all mating surfaces for burrs and distortion. Inspect all plugs and valves for burrs and scores. NOTE: Crocus cloth can be used to polish the valves and plugs if care is taken to avoid rounding the sharp edges of the valves and plugs.

Inspect all springs for distortion. Check all valves and plugs for free movement in their respective bores. Valves and plugs, when dry, must fall from their own weight in their respective bores. When assembling the control valve body, always use the following procedure:

Arrange all parts in their correct position. Rotate the valves and plugs when inserting them in their bores, to avoid shearing of soft body castings.

Install the valve body plate on the upper body. Do not tighten the screws. Install the rear pump check valve spring, valve and sleeve in the lower body. Position the lower body on the upper body. Place the separating plate on the lower body. Install the lower body cover, then tighten the attaching bolts finger tight. Align the valve body attaching bolt holes in the valve body plate and lower body. Tighten the four valve body

bolts, equally, to 4-6 foot-pound torque (Fig. 108).

**CAUTION:** Excessive tightening of these bolts may distort the valve bodies, causing the valves or plugs to stick.

Install the two lower cover to lower body screws. Tighten cover and body screws to 20-30 inch-pounds. Install the plate on the lower end body, then tighten the attaching screws. **NOTE:** Lubricate all valves and plugs with Automatic Transmission Fluid, Type "A" before installing them in their respective bores. Install the orifice control and the 2-3 shift valve plugs in the end body. Install the transition valve spring and valve, the orifice control valve spring and valve, and the 2-3 shift valve in the lower body. Install the shift valve inner and outer springs. Install the end body on the lower body (Fig. 109). **NOTE:** Make sure the inner spring is piloted on the 2-3 shift valve plug.

Install the governor plug in the lower body. Install the low inhibitor valve spring in the valve and install the valve. Install the lower body side plate (Fig. 110). Install the 1-2 shift valve and spring in the cover, then install the rear servo check valve and spring. Install the end plate to the cover. Install the compensator cut-off valve in the upper body.

Install the throttle valve. Position the upper body rear plate on the upper body (Fig. 111), with the plate between the end bands of the throttle valve. Install one plate-to-body screw in the hole next to the throttle valve. Position the throttle valve return spring on the plate, and secure the plate in place with the remaining plate-to-valve body screws. Install the compensator valve and spring, the throttle valve spring and the downshift valve.

Install the modulator small spring, valve, spring and retainer as an assembly. Install the plug in the compensator

valve sleeve, castellated end out, and install the assembly in the body, with the smooth end toward the body.

Install the upper body front plate (Fig. 112). Install the manual valve. Pressing the downshift valve into its bore, insert the vacuum control lever hook into the downshift valve and control lever. Install the retaining ring on the hook at the vacuum control lever.

#### GOVERNOR

Remove the governor body cover plate attaching the screws and remove the plate. Remove the governor body attaching screws, then remove the body from the counterweight. Slide the retainer from the governor weight and remove the spring. Remove the valve and weight from the governor body (Fig. 113).

Inspect the governor weight, valve and bore for scores. Minor scores may be removed with crocus cloth. Replace the governor valve, weight or body if deeply scored. Check for free movement of the weight and valve in the bore. Inspect all fluid passages in the governor body and counterweight for obstructions. All fluid passages must be clean. Inspect the mating surfaces of the governor body and counterweight for burrs and distortion. Check governor spring retainer washer for burrs. The mating surfaces must be smooth and flat. Install the governor valve in the bore of the governor body. Install the weight in the governor valve. Position the spring over the stem of the weight and into the governor valve. Compress the spring and slide the retainer onto the stem of the weight and release the spring tension. Install the governor body on the counterweight. **NOTE:** Make sure the fluid passages in the body and counterweight are aligned.

Install the governor body attaching screws. Position the governor body cover plate on the body, then install the cover plate screws.

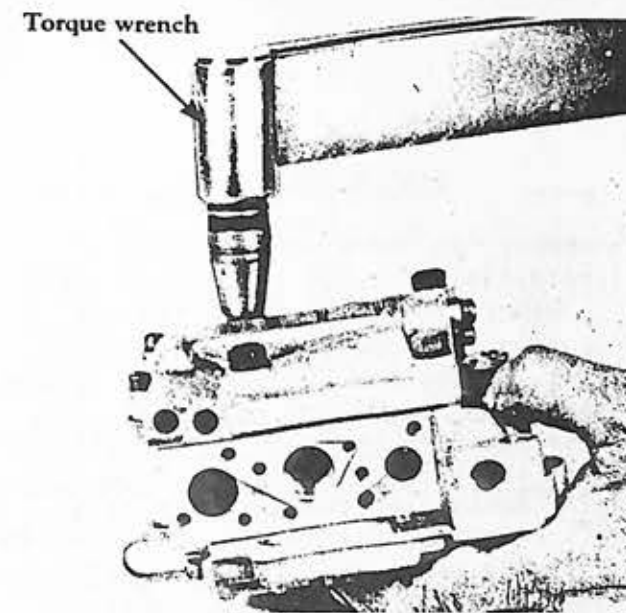

Fig. 108-Tightening Four Valve Body Bolts

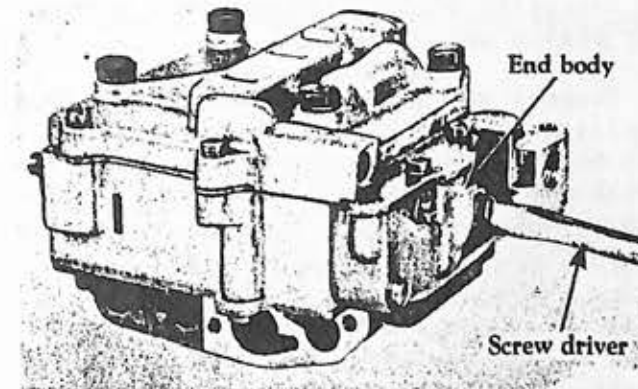

Fig. 109

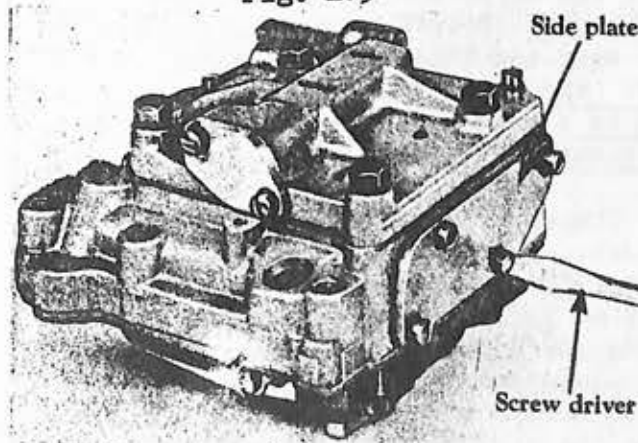

Fig. 110

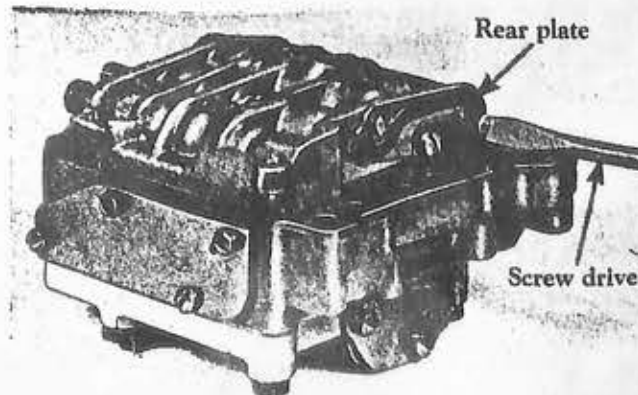

Fig. 111

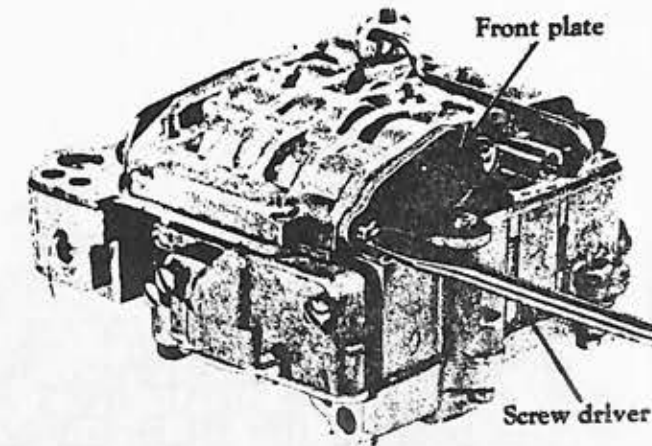

Fig. 112

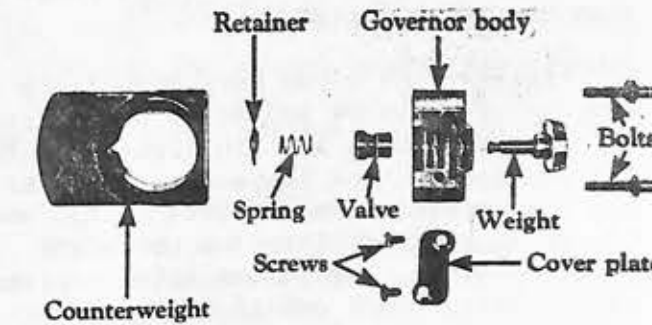

Fig. 113 Governor Disassembled

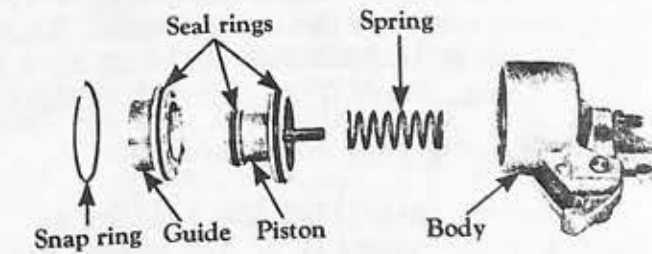

Fig. 114 Front Servo Disassembled

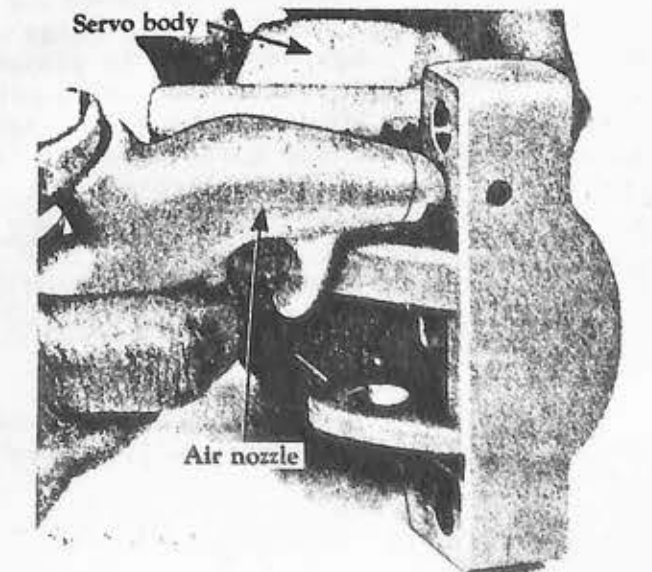

Fig. 115

## FRONT SERVO

Remove the servo piston guide snap ring (Fig. 114). CAUTION: The servo piston is spring-loaded, apply pressure to the piston when removing the snap ring. Remove the servo guide and piston from the servo body. NOTE: If necessary, tap the servo piston guide lightly with a soft hammer to remove it from the servo body. Remove the servo spring. Remove the guide from the servo piston, then remove the seal from the guide. Remove the rings from the servo piston.

Inspect the servo body for cracks and the piston bore and servo piston stem for scores. Check all fluid passages for obstructions. Check the actuating lever for free movement and inspect it for wear. If necessary to replace the actuating lever or shaft, remove the retaining pin and push the shaft out of the bracket. Inspect the adjusting screw threads and the threads in the lever. Check the servo spring and servo band strut for distortion. Inspect the servo band lining for excessive wear and bond to metal band. NOTE: The band should be replaced if worn to a point where the grooves are not clearly evident. Inspect the band ends for cracks and check the band for distortion.

Before installing the seal rings, make a trial assembly of the piston guide and body. Check the longitudinal and rotary movement of the member for freedom from binding. Install the servo spring in the servo body. Install new, large and small seal rings on the servo piston. Install a new seal ring on the servo guide, then install the guide on the servo piston. Install the piston and guide assembly in the servo body. NOTE: Lubricate the parts with Automatic Transmission Fluid, Type "A," before assembly. Press the guide down, then install the snap ring. CAUTION: Make sure the snap ring is fully seated in the groove.

Install the adjusting screw and lock-nut in the actuating lever if they were previously removed.

## REAR SERVO

Remove the servo actuating lever shaft retaining pin with a 1/8 inch pin punch. Remove the shaft and actuating lever needle bearings and thrust washers. (Fig. 14). Press down on the servo spring retainer, then remove the snap ring. NOTE: Release the pressure on the retainer slowly to prevent the spring from flying out. Remove the retainer and servo spring. Force the piston out of the servo body with air pressure (Fig. 115). CAUTION: Hold one hand over the piston to prevent damage. Remove the piston seal ring. Remove the accumulator piston snap ring from the servo piston. Remove the accumulator piston and spring.

Inspect the servo body for cracks and the piston bore for scores. Inspect the servo body-to-transmission-case mating surface for burrs. Check the fluid passages for obstructions. Inspect the fluid passage plugs for tightness in the body. Inspect the accumulator piston stem for scores. Inspect the actuating lever socket for scores and wear. Check the actuating lever and shaft for wear. Inspect the servo spring for distortion. Inspect the servo band lining for excessive wear and bond to metal band. NOTE: The band should be replaced if worn to a point where the grooves are not clearly evident.

Inspect the band and the struts for distortion. Inspect the band ends for cracks. Inspect the accumulator piston and bore for scores, and inspect the spring for distortion. Be sure the piston slides freely in the bore. Install the accumulator spring and piston. Compress the spring with a "C" clamp to install the snap ring. Install a new seal on the servo piston. NOTE: Lubricate the parts with Automatic Transmission Fluid, Type "A," before assembly.

Install the piston in the servo body. Install the servo spring with the small coiled end against the servo piston. Install the spring retainer. Compress the

spring with a "C" clamp, then install the snap ring. CAUTION: Make sure the snap ring is fully seated in the groove. Install the needle bearings in the actuating lever. Install the actuating lever and thrust washers with the socket in the lever bearing on the piston stem. Install the actuating lever shaft, aligning the retaining pin holes, and install the pin. Check the actuating lever for free movement.

## TRANSMISSION CASE AND LINKAGE

This section discusses the disassembly and assembly procedures concerning the transmission case and linkage.

### DISASSEMBLY

Remove the manual inner lever shaft nut (Fig. 116). Then remove the inner lever (Fig. 117). CAUTION: DO NOT ALLOW THE DETENT BALL TO FLY OUT OF THE CASE. Remove the detent ball and spring (Fig. 117). Remove the manual lever and shaft from the transmission case (Fig. 118). Remove the manual lever and shaft seal from the transmission case (Fig. 118). Remove the transmission vent.

## INSPECTION OF TRANSMISSION CASE AND CENTER SUPPORT

Clean the case thoroughly with cleaning solvent. Blow out all passages. Inspect the case for cracks and stripped threads. Inspect the gasket surfaces and mating surfaces for burrs. Check the vent for obstructions and leakage. Inspect the case bushing and center support bushing for scores.

## INSPECTION OF LINKAGE

Inspect the manual shaft inner lever, and manual shaft and lever for wear. Inspect the detent spring for distortion.

### ASSEMBLY

Coat the new manual shaft and lever seal with a non-hardening sealing compound, then install the seal in the transmission case, using seal driver as shown in Fig. 120. Install the manual lever and shaft in the case as shown in Fig. 118. Install the inner lever on the manual shaft and attach with nut. Tighten the nut to 35-40 foot-pounds torque. Install the detent spring and ball. NOTE: Use a piece of thin wall tubing to depress the ball and spring while rotating the inner lever.

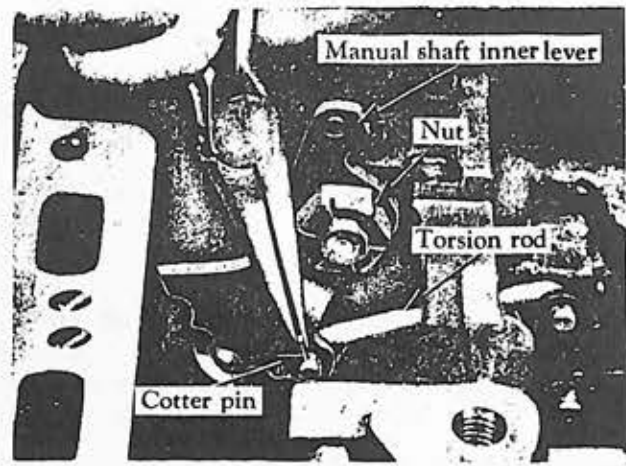

Fig. 116

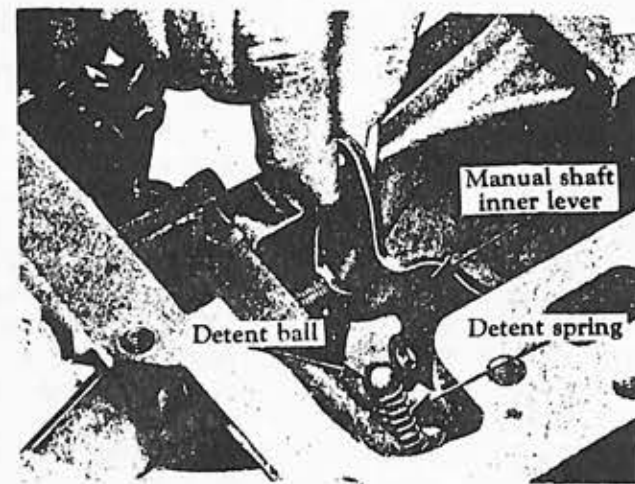

Fig. 117

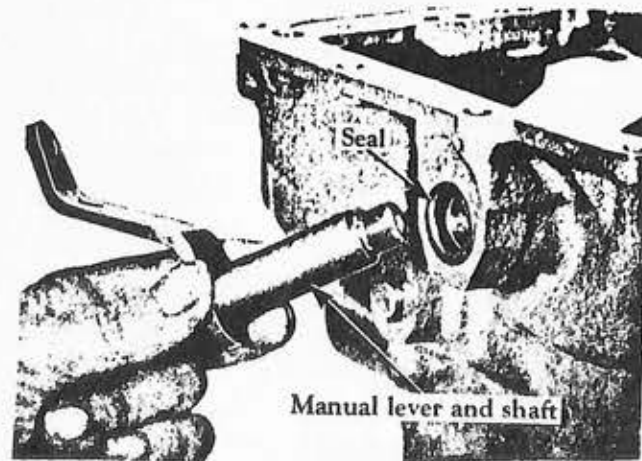

Fig. 118

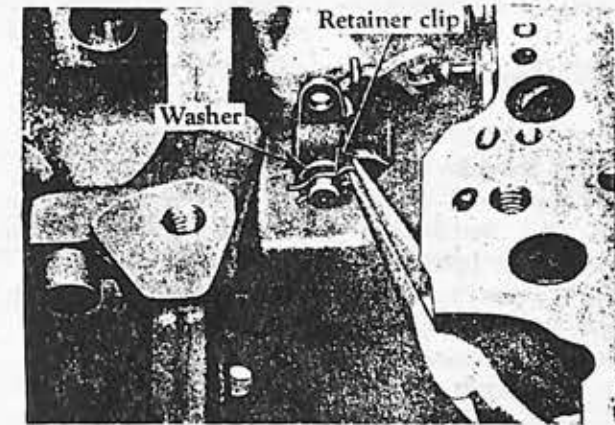

Fig. 119

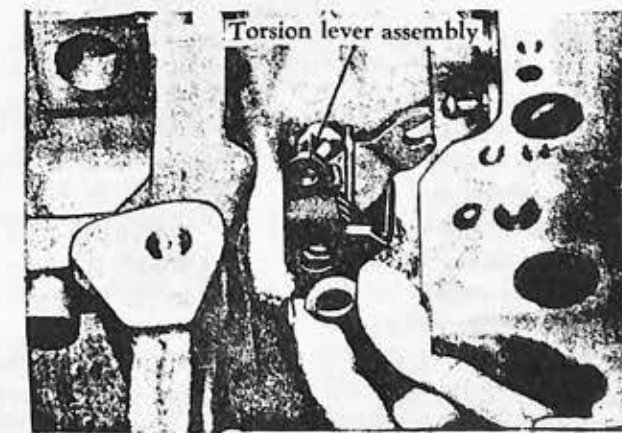

Fig. 120

Check the operation of the linkage. The linkage should operate freely without binding. Install the transmission vent.

#### INSTALLATION OF SUB-ASSEMBLIES

The transmission assembly procedures include the installation of the sub-assemblies in the transmission case, and checking the transmission end play. Do not use force to assemble the mating parts. If the parts do not assemble freely, examine them for the cause of difficulty. Always use new gaskets during the assembly operation. IMPORTANT: Use only Automatic Transmission Fluid, Type "A," to lubricate transmission parts. Never use any other type of lubricant.

#### CLUTCH ASSEMBLIES

Install the front band in the transmission case so the anchor end is aligned with the anchor in the case. Lift the clutch assemblies out of the holding block. NOTE: Do not allow the clutches to separate.

Install the sub-assemblies in the transmission case from the rear, while positioning the servo band on the drum. Hold the units together while making the installation (Fig. 55). Position the center support in the case, aligning the hole in the center support with the hole in the side of the case (Fig. 54). Install the right and left center support bolts and external tooth lockwashers as shown in Fig. 54. NOTE: The lockwashers must be installed with the rolled edge toward the transmission case to insure a tight seal.

#### PINION CARRIER AND OUTPUT SHAFT

Position the rear servo band in the transmission case, with the strut ends up (Fig. 53). Place the anchor end with the depression toward the adjusting screw. Install a bronze thrust washer on the thrust face inside the pinion carrier. To install the pinion carrier assembly, position the rear band over the drum while

meshing the planet pinions. Install the two seal rings on the primary sun gear shaft and check the rings for free movement in the grooves. Install the selective thrust washer on the rear of the pinion carrier (Fig. 50). Retain the washer with fluid. NOTE: If the end play was not within specifications, when checked prior to disassembly, replace the washer with one of proper thickness.

The following selective washers are available:

.061 - .063 inch;  
.074 - .076 inch;  
.092 - .094 inch;  
.105 - .107 inch;

Install the output shaft, carefully meshing the internal gear with the pinions (Fig. 50).

#### REAR PUMP

Position the rear pump drive key in the keyway on the output shaft. Position new front and rear gaskets on the pump body. Retain the gaskets with transmission fluid. Then install the rear pump. CAUTION: Be sure the drive key is aligned with the keyway in the pump drive gear.

#### GOVERNOR

Position the governor drive ball in the pocket in the output shaft. Retain the ball with transmission fluid. Install the governor assembly, aligning the groove with the ball in the output shaft (Fig. 48). Install the governor snap ring. NOTE: Install the governor with the governor cover plate toward the front of the transmission.

#### DISTRIBUTOR

Place the four seal rings in the distributor sleeve and check the ring gap. Check the fit of the seal rings in the grooves in the output shaft. The rings should rotate freely. Install the rings in the grooves of the output shaft.

Install the distributor sleeve on

the output shaft, chamfer forward (Fig. 45). Lubricate the parts to simplify assembly. Install the distributor and tubes on the distributor sleeve (Fig. 44). Make sure the fluid passages in the sleeve and the distributor are aligned. Install the attaching bolts and lockwashers. Tighten the bolts finger tight. Insert the distributor tubes in the transmission case until the spacer on the center tube is against the case; then tighten the distributor attaching bolts to 8-10 foot-pounds torque. Install a new seal on the rear pump outlet tube and install the tube in the transmission case and rear pump body.

#### EXTENSION HOUSING

Install the rear bearing space washer (Fig. 43). Position a new extension housing gasket to the transmission case. Retain the gasket to the case with transmission fluid. Install the extension housing to the transmission case as shown in Fig. 42. Secure the housing with attaching bolts and external tooth lockwashers. NOTE: The lockwashers must be installed with the rolled edge toward the transmission case to insure a tight seal. Tighten the extension housing attaching bolts to 28-30 foot-pounds torque. Install the governor cover and a new gasket on the housing. Drive the rear bearing on the output shaft and into the extension housing. Install the bearing snap ring.

#### BRAKE ANCHOR BRACKET

Position the speedometer drive gear on the output shaft. Using a suitable piece of tubing, drive the speedometer drive gear onto the output shaft until it bottoms against the rear bearing. Position a new anchor bracket gasket on the extension housing and install the anchor bracket, securing it to the housing with bolts and lockwashers. Install a new seal in the anchor bracket, using driver as shown in Fig. 66.

#### FRONT PUMP

Position a new front pump gasket in the counterbore of the transmission

case. Install the front pump, aligning the pump bolt holes with holes in the case (Fig. 52). Install three of the front pump attaching bolts. Tighten the bolts to 17-22 foot-pounds torque.

#### CHECK TRANSMISSION END PLAY

Mount the dial indicator support, in a front pump bolt hole. Mount a dial indicator on the support so the contact rests on the end of the turbine shaft (Fig. 35). Use a large screwdriver to pry the front of the clutch cylinder toward the rear of the transmission (Fig. 36). Set the dial indicator to zero. Remove the screwdriver and pry the units toward the front of the transmission by inserting a screwdriver between the large internal gear and the rear drum shown in Fig. 37. Note the indicator reading. End play should be .010 to .029 inch. Remove the indicator, then remove the indicator support from the front pump. Install the one remaining front pump attaching bolt. Tighten the bolt to 17-22 foot-pounds torque.

#### FRONT SERVO

Position the front band forward in the case with the ends up. Position the servo strut with the slotted end aligned with the servo actuating lever and the small end aligned with the band end. Rotate the band, strut, and servo into position, engaging the anchor end of the band with the anchor pin in the case. Locate the servo on the dowel in the case, then install the attaching bolt. NOTE: Tighten the attaching bolt only two or three threads. Install the servo tubes.

#### REAR SERVO

Position the servo anchor strut, then rotate the rear band to engage the strut. Position the servo actuating lever strut with a finger, then install the servo and attaching bolts (Fig. 33). Tighten the bolts to 40-45 foot-pounds torque.

#### PRESSURE REGULATOR BODY

Install the pressure regulator body and attaching bolts. Tighten the bolts to



17-22 foot-pounds torque. Install the control and converter valve guides and springs. Install the spring retainer (Fig. 24). Install a new seal ring on the rear pump intake tube, then install the tube in the case.

#### CONTROL VALVE BODY

Install the control valve assembly, using care to align the servo tubes with the control valve. Align the manual valve with the actuating pin in the manual shift inner lever. Do not tighten the attaching bolts. Install the large control pressure tube in the valve body and regulator. Install the small control pressure compensator tube in the valve body and regulator. Install the lubrication tube in the rear pump and regulator body. Tighten the control body attaching bolts to 8-10 foot-pounds torque. Tighten the front servo attaching bolt to 30-35-pounds torque.

#### FRONT SERVO ADJUSTMENT

Loosen the front servo adjusting screw locknut, then back the nut off three turns. Loosen the adjusting screw five complete turns. Using the front band adjusting wrench shown in Fig. 3, insert the  $\frac{1}{4}$  inch spacer, between the lever and the stem, then tighten the screw until the ratchet over-runs. Hold the adjusting screw stationary and tighten the locknut clockwise to 20-25 foot-pounds torque. Remove the gauge block.

#### REAR SERVO ADJUSTMENT

Loosen the adjusting screw locknut three turns with the  $\frac{3}{4}$  inch socket of the rear band adjusting wrench. Back off the adjusting screw until free travel is obtained. Use the special tool shown in Fig. 4, tighten the adjusting screw until the ratchet over-runs, then back off the adjusting screw one and one-half turns. Hold the rear servo adjusting screw stationary and tighten the locknut to approximately 40 foot-pounds torque.

#### FLUID SCREEN AND PAN

Position the fluid screen over the rear pump inlet tube, then over the front pump inlet tube. Press the screen down firmly. Install the screen retaining clip.

Place a new gasket on the transmission case, then install the pan. Install the attaching bolts and lockwashers. Tighten the bolts to 10-13 foot-pounds torque.

#### ADJUSTMENTS

The automatic transmission adjustments given in this section should be performed in the order in which they appear. Be sure that all specifications given here are closely adhered to.

##### A. ENGINE IDLE SPEED ADJUSTMENTS:

Place the selector lever in the "N" (neutral) position, then start the engine. Run the engine at idle speed until its normal operating temperature is reached.

Check the engine idle speed with a tachometer. The correct idle speed should be 450-500 r.p.m. If the idle speed is not within these limits, turn the carburetor idle adjusting screw until the correct idle speed is reached.

##### B. MANUAL LINKAGE ADJUSTMENT:

With the engine turned off, disconnect the manual shift rod from the selector lever on the steering column and the transmission lever.

Position the selector lever so the indicator is down against the stop in the "D" (drive) position. Place the transmission manual lever in the "D" (drive) detent (second from the top of the transmission).

Position the manual shift rod into

the ball joint on the steering column. The opposite end of the rod should be installed in the transmission shift lever and secured with a washer and cotter pin. Then tighten the ball joint nut at the steering column lever.

Move the selector lever through all positions, checking the alignment of the pointer in all positions.

##### C. STARTER NEUTRAL SWITCH ADJUSTMENT:

Check the starter circuit in all selector lever positions. The circuit must be open in all positions except "N" (neutral). To adjust, loosen the neutral switch to the steering column attaching screws. Position the switch so that the starter circuit is closed when the selector lever is at "N" (neutral).

##### D. KICKDOWN SWITCH ADJUSTMENT:

The kickdown switch is located in the toeboard under the throttle treadle.

To adjust the kickdown switch, loosen the two nuts, one above and one below the toeboard and turn the upper nut clockwise or counterclockwise to obtain the proper clearance of approximately  $\frac{1}{4}$  inch between the switch and throttle treadle when the throttle plates are in a wide open position.

##### E. VACUUM CONTROL UNIT:

The vacuum control and solenoid unit located at the rear of the transmission (Fig. 28) should be installed so that the distance between its front face and the case is  $\frac{3}{8}$  inch. This is the factory setting. Tighten locknut.

If, after operating the vehicle, shifts are delayed or are soft allowing the engine to "runup" or get away, operation of the vacuum control can be checked as follows:

Connect a tachometer on the engine. Remove the  $\frac{1}{8}$  inch pipe plug located on the left side of the case near the front of the transmission. Install a pressure gauge line connector at this location, then connect the pressure gauge at this point and place the gauge inside the cab. Start the engine and move the selector lever in "D" (drive) position. Apply hand and service brakes and accelerate the engine until 1,000 r.p.m. is reached. At this time check the reading on the pressure gauge. In most installations, the correct pressure reading is 90-105 p.s.i.

NOTE: Do not operate the engine under the above conditions over 10 seconds at any one interval when performing this check.

If correct oil pressure is not indicated, place a vacuum gauge in the line from the manifold to the vacuum unit at the vacuum unit. Repeat the above check. The vacuum gauge should show 10.5 - 12.0 inches of mercury at 1,000 r.p.m. A low reading indicates a vacuum leak. While a high reading indicates a plugged or flattened vacuum line. Leaks can occur in the fittings, the vacuum line or the vacuum unit. A correct reading should be obtained before proceeding further.

To allow for tolerance buildup, the vacuum unit can be set closer to the case which will raise the control pressure slightly at the 1,000 r.p.m. check point or farther away which will lower the control pressure at the check point. Dimensional limits are  $\frac{11}{32}$  inch to  $\frac{13}{32}$  inch;  $\frac{1}{2}$  turn of vacuum unit moves it in or out  $\frac{1}{32}$  inch. This means that the allowable adjustment on the vacuum unit is  $\frac{1}{2}$  turn either way from the factory setting of  $\frac{3}{8}$  inch. Any vacuum unit setting outside of these limits will be ineffective; it may actually cause transmission malfunction which could result in damage to clutches or bands.

After setting, be sure the locknut and

the vacuum line are tight and that the electrical connection to the kickdown switch has been made.

**CAUTION:** Do not operate the engine, under these conditions, over 10 seconds at any one interval.

- For normal converter stall speed consult vehicle or transmission manufacturer.

**F. CONTROL PRESSURES:**

Control pressure varies with throttle opening and with road speed. When the vehicle is held stationary with the brakes, control pressure varies with throttle opening only. There are definite specifications covering control pressures in each model of the transmission built. They cover the following:

In general, if pressures are below specifications, an internal leak or a bad front pump is indicated. If pressures are above specifications, sticking valves in control valve or regulator valve assemblies are indicated, except as noted below.

**NOTE:** When idle pressures are found to be above specifications, the vacuum control unit should be checked for proper operation before proceeding with further checks.

- Control pressures in all manual selector positions with engine at idle, and vehicle stationary.
- Control pressures in all manual selector positions with vehicle stationary and throttle wide open.

**G. CHECKING CONVERTER OPERATION:**

Connect a tachometer on the engine, apply hand brakes and service brakes. Start the engine and place the manual selector lever at "D" (drive) or "L" (low) range. Accelerate the engine to wide open throttle and observe the tachometer reading.

- A reading of 400 or more r.p.m. below the normal stall speed indicates a slipping one-way clutch in the converter or a broken stator support shaft.
- A stabilized reading at the specified normal stall speed (one which remains steady for 5 to 10 seconds) indicates the converter is operating normally.
- A reading which will not stabilize and continues to increase to over 2,000 r.p.m. sometimes accompanied by whirring or scraping noises indicates internal damage to the converter which causes it to be inoperative. Extreme caution must be observed in making this check so as not to assume the converter is inoperative without first making the other checks listed under "inoperative in all ranges" in the diagnosis section of the manual.

- Do not operate the engine at wide open throttle over 10 seconds at any one interval while performing this check.

**DRIVING UNITS**

|              | Neutral | Drive First | Drive Intermediate | Drive Direct | Low     | Reverse |
|--------------|---------|-------------|--------------------|--------------|---------|---------|
| Front Band.. | Free    | .....       | Applied            | .....        | .....   | .....   |
| Rear Band... | Free    | Applied     | .....              | .....        | Applied | Applied |
| Front Clutch | Free    | Applied     | Applied            | Applied      | Applied | .....   |
| Rear Clutch. | Free    | .....       | .....              | Applied      | .....   | Applied |

**TORQUE SPECIFICATIONS**

| Name  | Torque (Ft-Lbs) | Name   | Torque (Pt. Lbs) |
|---|-----------------|--|------------------|
| Converter Cover to Converter Pump Nuts.....                 | 15-28           | Oil Pan Drain Plug.....                          | 20-25            |
| Converter Pump Hub to Converter Pump Housing Bolts.....     | 8-10            | Rear Band Adjusting Screw Locknut.....           | 35-40            |
| Front Pump to Transmission Case Bolts.....                  | 17-22           | Front Band Adjusting Screw Locknut.....          | 20-25            |
| Front Servo to Transmission Case Bolts.....                 | 30-35           | Detent Lever Attaching Nut.....                  | 35-40            |
| Rear Servo to Transmission Case Bolts.....                  | 40-45           | Front Pump Cover Attaching Screws.....           | 25-35 *          |
| Planetary Support to Transmission Case Bolts.....           | 20-25           | Rear Pump Cover Attaching Screws (1/4").....     | 60-60 *          |
| Oil Distributor to Oil Distributor Sleeve Bolts.....        | 8-10            | Rear Pump Cover Attaching Screws (#10-24).....   | 20-30 *          |
| Upper Valve Body to Lower Valve Body Bolts.....             | 4-6             | Governor Inspection Cover Attaching Screws.....  | 50-60 *          |
| Control Valve Body to Transmission Case Bolts.....          | 8-10            | Converter Cover Drain Plug.....                  | 7-10             |
| Pressure Regulator Assembly to Transmission Case Bolts..... | 17-22           | Transmission Vent Assembly... ..                 | 7-10             |
| Extension Assembly to Transmission Case Bolts.....          | 28-33           | Governor Valve Body to Counterweight Screws..... | 50-50 *          |
| Oil Pan to Transmission Case Bolts.....                     | 10-13           | Governor Valve Body Cover Screws.....            | 20-30 *          |
| Case Assembly - Gauge Hole Plug.....                        | 7-15            | Pressure Regulator Cover Attaching Screws.....   | 20-30 *          |
|   |                 | Control Valve Body Screws.....                   | 20-30 *          |
|   |                 | Control Valve Body Plugs.....                    | 10-14            |
|   |                 | Control Valve Lower Body Plug.....               | 7-15             |

\* Inch Pounds

## ROAD TEST AND PERFORMANCE CHECKS

A thorough road test should be made to determine the shift speeds and performance of the transmission (Shift speed specifications for the specific application furnished by Warner Gear).

The initial application of the various bands and clutches should be checked in all driving ranges by stopping the vehicle and moving the selector lever to the "D" (drive), "L" (low), and "R" (reverse) ranges.

A driving test should be made in the "D" (drive) range to check shift speeds. The shift speeds that should be determined are:

- A. Light throttle upshift speed from 1st to 2nd.
- B. Light throttle upshift speed from 2nd to 3rd.
- C. Kickdown upshift speed from 1st to 2nd.
- D. Kickdown upshift speed from 2nd to 3rd.
- E. Maximum kickdown speed 3rd to 2nd.
- F. Maximum kickdown speed 2nd to 1st.
- G. Closed throttle downshift speed 3rd to 2nd.
- H. Closed throttle downshift speed 2nd to 1st.

## FINAL DIAGNOSIS

After the initial checks and the road checks have been made, the conditions noted should be checked against the conditions below to determine the cause of the difficulty.

### A PRELIMINARY CHECK OF THE FOLLOWING ITEMS WILL OFTEN ISOLATE THE DIFFICULTY:

- 1. Fluid Level
- 2. Engine Idle
- 3. Control Pressure
- 4. Vacuum Control Unit
- 5. Manual Linkage

If none of the preliminary checks and subsequent corrections eliminate the difficulty, the following list of causes and corrections will provide a guide for further investigation:

| <u>CAUSE</u>                               | <u>INITIAL ENGAGEMENT TOO ROUGH</u>                              | <u>CORRECTION</u> |
|--|--|-------------------|
| 1. Control pressure too high.              | 1. Clean control valve assembly and pressure regulator assembly. |                   |
|  | <u>INITIAL ENGAGEMENT DELAYED</u>                                |                   |
| 1. Rear band loose.                        | 1. Adjust rear band.   |                   |
| 2. Control pressure too low at idle speed. | 2. Clean control valve assembly and pressure regulator assembly. |                   |
|  | (a) Check front pump for wear.                                   |                   |
|  | (b) Check fluid circuits for leaks, and correct.                 |                   |

## INOPERATIVE IN ALL RANGES

| <u>CAUSE</u>   | <u>CORRECTION</u>  |
|--|--|
| 1. No control pressure.  | 1. Check front pump and front pump drive tangs on converter.<br>(a) Inspect and clean pressure regulator assembly.               |
| 2. Rear band and/or servo inoperative. (Applies only to transmissions with 1st gear start in "D" (drive) range.) | 2. (a) Check band adjustment.<br>(b) check rear servo action with air pressure.<br>(c) inspect and clean control valve assembly. |
| 3. Converter failure.  | 3. Check converter operation.  |

### NO DRIVE IN "D" OR "L" POSITION

|                                 |  |
|---------------------------------|--|
| 1. Control pressure low.        | 1. Clean control valve assembly and pressure regulator valve assembly. |
| 2. Front clutch will not apply. | 2. Check front clutch action with air pressure.                        |
| 3. Rear band will not apply.    | 3. Check rear servo and band with air pressure.                        |
| 4. Transition valve stuck.      | 4. Clean control valve assembly.                                       |

### NO DRIVE IN "R" POSITION

|                                |  |
|--------------------------------|--|
| 1. Control pressure low.       | 1. Clean control valve assembly and pressure regulator valve assembly. |
| 2. Rear clutch will not apply. | 2. Check rear clutch action with air pressure.                         |
| 3. Rear band will not apply.   | 3. Check rear servo action with air pressure.                          |
| 4. Transition valve stuck.     | 4. Clean control valve assembly.                                       |

### LOCKS UP IN "D" POSITION (1ST)

|  |   |
|--|---|
| 1. Rear clutch applied.  | 1. (a) Clean control valve assembly.<br>(b) Clean governor valve assembly.<br>(c) Check clutch for mechanical failure.<br>(d) Check for broken seal rings on primary sun gear shaft and output shaft. |
| 2. Front band applied. (This applies to transmissions with 1st gear start in "D" range.) | 2. (a) Clean control valve assembly.<br>(b) Clean governor valve assembly.<br>(c) Check band and servo for mechanical failure.  |

### LOCKS UP IN "D" POSITION (2ND)

|                         |   |
|-------------------------|---|
| 1. Rear band applied.   | 1. Check band and servo for mechanical failure. |
| 2. Rear clutch applied. | 2. Check clutch for mechanical failure.         |

LOCKS UP IN "D" POSITION (3RD)

CAUSE

1. Rear band applied.
2. Front band applied.

CORRECTION

1. (a) Clean control valve assembly.  
(b) Check band and servo for mechanical failure.  
(c) Check for broken seal rings and primary sun gear shaft and output shaft.
2. Check band and servo for mechanical failure.

LOCKS UP IN "R" POSITION

1. Front clutch applied.
2. Front band applied.

1. Check clutch for mechanical failure.
2. (a) Check band and servo for mechanical failure.  
(b) Clean control valve assembly.

SLIPS IN "D" OR "L" POSITION

1. Control pressure low.
2. Rear servo travel limited.
3. Front clutch slips.
4. Rear pump check valve stuck open.

1. Clean control valve assembly and pressure regulator valve assembly.
2. Check servo band for mechanical failure.
3. Check front clutch for mechanical failure.
4. Clean control valve assembly and check rear pump check valve.

SLIPS IN "R" POSITION

1. Control pressure low.
2. Rear servo travel limited.
3. Rear clutch slips.
4. Rear pump check valve stuck open.

1. Clean control valve assembly and pressure regulator valve assembly.
2. Check servo and band for mechanical failure.
3. (a) Check rear clutch for mechanical failure.  
(b) Check for broken seal rings on primary sun gear shaft and output shaft.
4. Clean control valve assembly and check rear pump check valve.

1-2 UPSHIFT ROUGH

1. Band adjustments.
2. Governor valve stuck.

1. Check and adjust bands.
2. Clean governor valve assembly.

1-2 UPSHIFT SLIPS

1. Control pressure low.
2. Band adjustments

1. Clean control valve assembly and regulator valve assembly.
2. Adjust bands.

1-2 UPSHIFT CLIPS

CAUSE

3. Governor valve stuck.
4. Front servo piston travel limited.

CORRECTION

3. Clean governor valve assembly.
4. Check with air pressure and correct.

NO UPSHIFT 1-2

1. Governor valve stuck.
2. 1-2 Shift valve stuck.

1. Clean governor valve assembly.
2. Clean control valve assembly.

1-2 UPSHIFT TOO EARLY

1. Governor valve stuck.

1. Clean governor valve assembly.

1-2 UPSHIFT TOO LATE

1. Governor valve stuck.
2. Leak in governor circuit.

1. Clean governor valve assembly.
2. (a) Clean control valve assembly and regulator valve assembly.  
(b) Check for broken seal rings on output shaft.

3. Control pressure too high.

3. Clean control valve assembly and regulator valve assembly.

2-3 UPSHIFT SLIPS

1. Control pressure low.
2. Front band adjustment.
3. Governor valve stuck.
4. Internal leaks.

1. Clean control valve assembly.
2. Adjust front band.
3. Clean governor valve assembly.
4. Check and correct.

NO UPSHIFT 2-3

1. Governor valve stuck.
2. 2-3 shift valve stuck.

1. Clean governor valve assembly.
2. Clean control valve assembly.

2-3 UPSHIFT EARLY

1. Governor valve stuck.

1. Clean governor valve assembly.

2-3 UPSHIFT LATE

1. Governor valve stuck.
2. Leak in governor circuit.
3. Control Pressure too high.

1. Clean governor valve assembly.
2. Check and correct.
3. Clean control valve assembly and regulator valve assembly.

3-2 DOWNSHIFT ROUGH (CLOSED THROTTLE)

1. Closed throttle control pressure too high.

1. (a) Adjust vacuum can as outlined in vacuum control unit section.  
(b) Clean control valve assembly and regulator valve assembly.

2. Orifice control valve stuck.

2. Clean control valve assembly.

3-2 KICKDOWN EARLY

- |                               |  |
|-------------------------------|--|
| 1. Control pressure too high. | 1. Adjust vacuum as outlined in vacuum control unit section. |
|-------------------------------|--|

NO KICKDOWN

- |  |   |
|--|---|
| 1. No electric current to vacuum can solenoid. | 1. Check and correct.   |
| 2. Vacuum can out too far.                     | 2. Adjust vacuum can as outlined under "Vacuum Control Unit" section. |

2-1 DOWNSHIFT ROUGH (CLOSED THROTTLE)

- |   |  |
|---|--|
| 1. Closed throttle control pressure too high. | 1. (a) Adjust vacuum can as outlined in vacuum control unit section.<br>(b) Clean control valve assembly and regulator valve assembly. |
| 2. Rear servo check valve stuck.              | 2. Clean control valve assembly.   |

NO PUSH START

- |                                    |   |
|------------------------------------|---|
| Q. Rear pump inoperative.          | 1. Check and correct.                       |
| 2. Pressure regulator valve stuck. | 2. Clean pressure regulator valve assembly. |

NO PARK POSITION

- |                                |                           |
|--------------------------------|---------------------------|
| 1. Manual linkage misadjusted. | 1. Check and correct.     |
| 2. Damaged internal linkage.   | 2. Check and correct.     |
| 3. Damaged park pawl.          | 3. Check and install new. |

The servicing or repair of the Automatic Transmission should be done only by an authorized passenger car or truck dealer. It is recommended, to insure continued satisfactory operation of the unit, that the front and rear bands of the transmission be adjusted after 1,000 miles of operation and at 15,000 mile intervals thereafter or as operation of the transmission indicates.

It is recommended that Type "A" Automatic Transmission Fluid be used. The oil level should be checked frequently and oil added as required.

---

IT IS RECOMMENDED, TO INSURE CONTINUED SATISFACTORY OPERATION OF THE DRIVERMATIC, THAT THE FRONT AND REAR BANDS OF THE TRANSMISSION BE ADJUSTED AFTER 1,000 MILES OF OPERATION AND AT 15,000 MILE INTERVALS, OR AS OPERATION OF THE TRANSMISSION INDICATES.

IT IS RECOMMENDED THAT TYPE A-SUFFIX A AUTOMATIC TRANSMISSION FLUID BE USED. THE OIL LEVEL SHOULD BE CHECKED FREQUENTLY AND OIL ADDED AS REQUIRED.

