

1938  
**PACKARD**  
**EIGHT**



**OWNER'S MANUAL**

**DRIVING, CARE, ADJUSTMENT  
AND EMERGENCY DATA**

**FOR CARS BEGINNING ENGINE NO. A-300001**

1938  
**PACKARD**  
**EIGHT**



**OWNER'S MANUAL**

**DRIVING, CARE, ADJUSTMENT  
AND EMERGENCY DATA**

**FOR CARS BEGINNING ENGINE NO. A-300001**

**A Shop Manual containing complete maintenance  
data is available gratis on request about January first**

**First Edition-1601-9-37**

# 1938 Packard Eight

Models 1601, 1601A, 1601D and 1602

## Alphabetical Index

	PAGE
BRAKES.....	45
CARBURETOR.....	28
CHASSIS SUSPENSION.....	40
CLEANING UPHOLSTERY.....	12
CLUTCH.....	37
COOLING SYSTEM AND ANTI-FREEZE.....	24
COURTESY + SKILL = SAFETY.....	8
ELECTRICAL SYSTEM.....	30
ENGINE.....	22
FUEL SYSTEM.....	26
FUSES—LOCATION, SIZE.....	32
HEARSE CHASSIS VARIATIONS.....	48
INSTRUMENTS AND CONTROLS.....	14
LAMP BULBS.....	35
LICENSE DATA.....	3
LUBRICATION CHART.....	21
LUBRICATION—GENERAL.....	18
LUBRICATION SCHEDULE.....	20
NEW CAR BREAK-IN INSTRUCTIONS.....	5
NUMBER INFORMATION.....	48
OWNER'S MAINTENANCE SCHEDULE.....	16
PARTS ORDERING.....	48
READY REFERENCE DATA.....	3
REAR AXLE.....	38
SERVICE TO PACKARD OWNERS.....	6
SHIPPING WEIGHTS.....	3
STARTING INSTRUCTIONS.....	16
STEERING GEAR.....	43
TIRES.....	47
TRANSMISSION.....	37
UNIVERSAL JOINT.....	37
WARRANTY.....	5
WASHING AND POLISHING.....	11
WIRING DIAGRAM.....	36

## Ready Reference Data

### Capacities

Cooling system... 16 quarts	Rear axle oil..... 6.0 pints
Crankcase oil..... 6 quarts	Transmission.... 2.0 pints
Gas tank..... 21 gallons	

### License Data

Car serial number location.....	Transfer at front of dash
Engine serial number location.....	Stamped on upper rear left side of block
Engine bore and stroke.....	3 $\frac{1}{4}$ " x 4 $\frac{1}{4}$ "
Engine horsepower A. M. A. rating..	33.8
Engine piston displacement.....	282.04 cu. in.
Wheelbase.....	1601—127"; 1602—148"

### Shipping Weights

	1601	1601-D	1602
Touring Sedan—4-Door.....	3650	3685	—
Touring Sedan—2-Door.....	3600	3630	—
Touring Sedan—4-Door, 7-Pass....	—	—	4195
Touring Sedan—Limousine, 7-Pass..	—	—	4245
Coupe—2-4 Pass.....	3550	—	—
Convertible Coupe, 2-4 Pass.....	3625	—	—
Convertible Sedan.....	3775	—	—
Coupe—2-Pass.....	3570	—	—

If weight of car ready for the road is desired, add 197 lbs. to cover gas, water and spare tire.

### Miscellaneous

Fuses—location.....	See page 32
Tire size.....	16 x 7.00—4 ply
Spark plugs.....	10 mm.—AC-103 or Champion Y4
Spark plug gap.....	.028" + or - .002"
Camber.....	$\frac{1}{2}^{\circ}$ + or - $\frac{1}{2}^{\circ}$
Caster.....	1 $\frac{1}{2}^{\circ}$ + or - $\frac{1}{2}^{\circ}$
Toe-in.....	$\frac{1}{32}$ " to $\frac{1}{16}$ "
Breaker point gap.....	.015"
Ignition timing—7 to 1 Head.....	2 $\frac{1}{2}^{\circ}$ to 4° B. T. D. C.
Ignition timing—Standard Head.....	6° to 8° B. T. D. C.
Tappet clearance—warm.....	Inlet .007", exhaust .010"

	1601	1602
Tire pressure—front—cold*.....	22 lbs.	24 lbs.
Tire pressure—rear—cold*.....	23 lbs.	27 lbs.
Over-all length.....	200 $\frac{13}{32}$ "	221 $\frac{13}{32}$ "
Over-all length with trunk rack.....	204 $\frac{31}{32}$ "	225 $\frac{31}{32}$ "

\*Meaning at atmospheric temperature.

## As Soon as You Take Delivery, Please Make Sure

1. Is the transfer, located on the forward side of the dash, stamped in the space marked Delivered by—City—Date—? If not ask the dealer to take care of this at once. You will not receive the benefits of the Owner's Service Policy unless this transfer is stamped.
2. Have you received your Packard Owner's Service Card? This card should be made out by the seller of the car. It enables you to obtain the service described in the Owner's Service Policy, should you require this at other than the service station delivering your car.
3. Has your dealer reported your purchase to the factory by means of the postal card supplied for this purpose?
4. Have you read the starting instructions for this particular car on page 16, and are you familiar with the "breaking in" information? This is on the next page.

The occasion may arise where your car must be serviced by other than a Packard dealer. In such cases, this book should be handed the shop proprietor so that it may serve as a guide, enabling him to maintain correct adjustment.

## When Parking, Lock Your Car

Locking is part of parking. Lock whenever you park. The greater the number of cars stolen the higher insurance rate you pay.

**Make a record of the key numbers.**

## New Car "Break-in"

The Manner in Which Any New Car is Driven for

### THE FIRST 250 MILES

has a very pronounced effect upon its subsequent operation and this applies to the brakes, gears, rear axle and other units, as well as to the engine.

All friction surfaces will burnish themselves to that high surface polish so essential to quietness, smoothness and durability, if not too highly stressed or loaded during the "break-in" period.

The best procedure is to refrain from even momentary wide-open throttle operation. Unless emergency demands it, do not fully open the throttle for acceleration or hill climbing and limit speed to 50 miles per hour until at least 250 miles have been driven. Observance of this advice will pay big dividends in ultimate satisfaction.

## Packard Warranty

*Packard Motor Car Company has warranted that for a period of ninety days from the date of original delivery to the purchaser of each new Packard car or before such car has been driven 4,000 miles, whichever event shall first occur, it will replace, free of charge, any part or parts thereof, including all equipment or trade accessories, except tires, supplied by it as standard equipment, claimed within that period to be defective and found by the Company upon examination to be so, provided such part or parts are returned to the Company within that period for credit or replacement. Such free replacement does not include transportation charges to or from the Packard factory.*

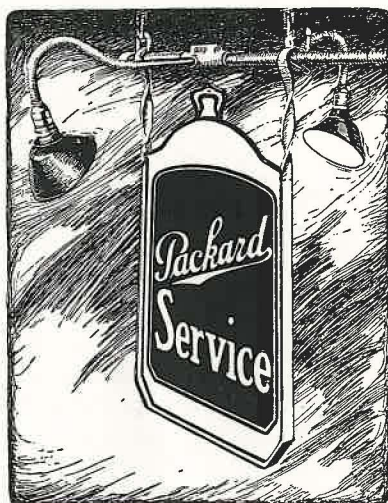

## Service to Packard Owners

### by Distributers and Dealers

It is intended that every owner of a Packard motor car shall receive fair and satisfactory treatment. Should any owner not receive it, we will appreciate being advised.

The original purchaser of a new Packard car will be entitled to the following services:

1. **Parts and Labor:** For 90 days after the original delivery of such motor car to the owner, provided the car has not been driven to exceed 4,000 miles, any parts, including all standard equipment, except tires, that may be adjudged by Packard Motor Car Company to be defective under its warranty will be replaced or repaired by any Packard dealer or distributor in the United States and Canada without charge to the owner for material or labor.

2. **Adjustment:** The owner is entitled during this period to receive two inspections and two necessary adjustments of his new car at any Packard Service Station, provided such

adjustments are not made necessary by accident, neglect or misuse.

3. **Inspections:** Throughout the life of the car, the owner is entitled to have it tested and inspected without charge every 30 days or 1,000 miles by an authorized Packard Service Station, provided such inspection requires no removal or dismantling of parts or units.

4. **Owner's Service Card:** At the time of delivery, the owner is provided with an Owner's Service Card which will introduce him to any authorized Packard Service Station and entitle him to receive service in accordance with this policy. The owner should carry the card with him at all times so he can present it when necessary.

5. **Tourist Privileges:** When touring, the owner is entitled, upon presentation of the Owner's Service Card, to all of the benefits of this policy during the warranty period at any authorized Packard Service Station in the United States and Canada, provided the date of delivery and name of the dealer from whom the car was purchased are stamped on the transfer provided for that purpose on the front face of the dash.

6. **Change of Residence:** In case the owner changes his residence from one location to another before the warranty period has expired, the Packard Service Station serving the locality into which the owner moves will, upon presentation of the Owner's Service Card, render any no-charge service to which the owner may be entitled.

7. **Service Charges:** Every authorized Packard Service Station is provided with a Manual containing the correct charges for service work. In order that maintenance costs may be kept as low as possible, these rates are based on careful studies of the shortest times for doing the service operations consistent with proper workmanship. Guaranteed Packard Parts are sold through authorized Packard Service Stations in the United States at the published list.

## Courtesy + Skill = Safety

Automobile engineering has always been devoted to safety and tremendous advances have been made. The modern motor car is, in itself an amazingly safe machine—ininitely more safe than cars of a few years back and yet, in spite of this, automobile accidents continue to reach shocking totals. A moral seems to be pointed in the fact that in nearly all parts of the civilized world educational campaigns are being conducted to make the public—both motoring and pedestrian—safety conscious.

Undoubtedly there are many drivers who need improvement. In most cases, fortunately, driving skill can be cultivated if there is any desire to become proficient. Deliberate indifference is an unfortunate attitude. Driving can be and is a lot of fun for those who do it well. Think of driving as a game—such as golf or tennis—and approach it with the same enthusiasm and expectancy. The ability to handle a motor car adroitly will give as much pleasure as does ability in any other sport.

A list of items considered essential in respect to skill, safety and comfort will be briefly discussed in the following paragraphs. We sincerely hope they will be helpful.

### Smooth Driving

Car operation can be smooth and graceful or it can be harsh and jerky. Acceleration and deceleration can be smooth even though rapid. Smooth operation is the mark of a finished driver.

### Anticipation

Ability to "anticipate" what "the other fellow" is going to do may sound like a fanciful illusion but it can be developed to a remarkable degree and is valuable in promoting safety and smooth driving. It proceeds, of course, from the practiced habit of being highly alert for indications of what is likely to occur.

### Speed

Modern cars perform so smoothly and quietly that there is no distinct sensation or impression of speed. Even at high speeds they seem to be "floating." It is advisable to glance at—and be guided by—the speedometer.

### Negotiating Curves

Inexpert drivers apparently consider it advantageous to maintain speed right up to the entrance, close the throttle, apply the brakes and "man-handle" the car through the curve. This method involves the danger of complete loss of control and does not save any time. A more skillful driver approaches and enters the curve at reduced speed. When the car is safely in the turn, a slight throttle opening will give a stabilizing

effect. From about the middle of the turn, the throttle opening can be gradually increased to give maximum acceleration out of the turn. The latter method is decidedly more safe, easier on tires and also faster.

### Passing Overtaken Cars

Many accidents proceed from errors in judgment of speed and distance. It is thought that many drivers make but **one** observation of the respective distances between their own car, the car to be passed and the oncoming car. **One** observation is not enough. Develop the habit of making **numerous careful appraisals** of the gap (think of it in terms of feet or yards) between your car and the car to be passed and the gap between the car to be passed and the on-coming car. **Repeated** observations of the **two** gaps will tell you reliably whether you have room to pass. Persistence in this method will develop a fine sense of "pace and distance" that will add to the safety and pleasure of driving.

### Mountains and Hills

Safety in mountainous or hilly country **demands** keeping always to the right side of the road. Do not "cut" curves and **never** pass a car at or near the brow of a hill. To attempt to do so is wantonly criminal.

### Low or Soft Shoulders

Concrete highways having low or soft shoulders present very definite hazards to fast drivers. To bring a car from such a shoulder back onto the pavement involves—in effect—**climbing a curb stone** and this cannot be done safely at speed. Under such conditions, cars are not responsive to light steering effort and the thoughtless driver who turns the steering wheel sharply in an effort to retain the pavement without first slowing down is courting serious disaster. Remember, too, that on such roads safety for passengers burdens the driver with the responsibility of being alert for any indication of a dangerous maneuver on the part of an oncoming driver.

### Skidding

Turn the front wheels in the direction of the skid, i. e., if the rear wheels are skidding to the right—turn the front wheels toward the right. To avoid a second though less violent skid in the opposite direction, the front wheels should be turned back gradually, as the speed of the rear wheel skid is diminishing, so that at the instant the rear wheels stop sliding, the front wheels will have been returned to the straight ahead position.

### Over-Steering

A fault common to nearly all drivers is a marked tendency to over-steer. Under certain conditions, over-steering is decidedly disadvantageous to say the least. The technique in skidding has been explained but most drivers seem unable to bring themselves to carry out the execution

accurately. In the case of skidding, failure to bring the front wheels back as indicated usually results in a greater reverse skid than is necessary. A sharp turn of the wheel in climbing from a low or soft shoulder at speed is difficult to correct rapidly enough and may send the car directly across the highway. Steering has been made slower to compensate for the tendency to oversteer but other difficulties are encountered if it is made too slow.

### Tire Blow-Out

Perhaps the best advice that can be given is to urge that nothing whatever be done until the necessity arises. The reason for this is that in many cases a blow-out produces nothing more than a mild tendency to skid and should be handled accordingly, but many persons suffer under the delusion that a blow-out demands heroic measures and proceed to make a harmless situation serious, or even dangerous. It is not possible to predict exactly what will happen in the event of tire failure because it depends entirely upon the conditions that exist at the time. Ordinarily, a blow-out results in skidding that may be mild or severe. If the car is intelligently handled, a blow-out is not apt to cause serious trouble.

### Applying Brakes

Violent braking is never advisable unless emergency demands it. It imposes terrific strains on all parts of the car including brakes and tires. Where slippery pavement, skidding or tire blow-out are involved, brake application should be **very cautiously** made.

### Dusty Road Ventilation

When driving over very dusty roads, the admission of dust to the front and rear compartments may be quite effectively prevented by closing all the windows and opening the cowl ventilator.

### Starting the Car on Ice

Getting the car under way on icy pavement can be more readily accomplished if care is taken not to spin the wheels. Use second or even high gear and open the throttle only slightly.

### Starting in Mud or Sand

In getting out of mud or sand, spinning of the wheels should be avoided to prevent them from "digging in." First speed may be necessary but don't open the throttle more than is necessary.

### Safety First

Public officials who shoulder the responsibility of motor car regulation quite logically look to the better class of drivers to set an example for others. May we, in the interest of all concerned, sincerely request that Packard owners "Always Drive Safely."

## Washing and Polishing

Fine lacquers applied under ideal conditions give Packard cars a beautiful finish of high luster that can be maintained indefinitely if given proper attention.

### Washing

Periodic cleaning is, of course, necessary. Fine dust may be safely removed by dusting with a soft clean cloth but "scrubbing" a dirty car with dry cloths is almost certain to scratch the highly polished surfaces.

Ordinarily, it is better practice to clean the car by washing with plenty of cold or lukewarm water. Soak the dirt off as much as possible and rinse sponges frequently to remove grit and dirt. Dry with a clean chamois. The use of an ordinary garden hose nozzle—adjusted to give a high velocity stream—will be very useful in removing dirt from the under side of the car and the inside of the wheels. A stiff brush may also be necessary. Avoid washing the car in the direct rays of hot summer sun or at any time when the lacquered surfaces are hot. Never wash the car with hot water.

In sections where salt, calcium chloride or similar chemicals are used on the roads, frequent washing of the car is necessary to preserve the finish. Where cars are to be exposed to freezing temperatures immediately after washing, all water must be removed from the edges of the adjustable windows to prevent them from becoming inoperative due to the formation of ice.

### Polishing

Natural weathering and an accumulation of traffic film will, in time, produce a dull appearance that washing will not correct. The original high luster can be fully restored by a thorough cleaning with Packard Body Polish or any other properly formulated body polish. The presence of color on the rubbing cloths simply indicates the removal of chalked or dead surface pigment loosened by exposure. All body striping is applied on top of the lacquer and requires careful treatment. Prolonged, vigorous rubbing will damage or may even remove the striping.

Oil or grease spots may also be removed with body polish. With a clean cloth, apply polish to the area of the spot only and polish out with a dry soft clean cloth. Special preparations are available that will remove tar or road oil without damage to the lacquer. Hardened lumps of tar can be more readily removed if first softened with lard or butter. If tar remover dulls the finish, use body polish to bring back the luster. Lacquer is resistant to many chemicals but alcohol will cause serious damage if allowed to remain. Any laquered surface upon which alcohol solutions have been spilled should immediately be flushed with water.

## Care of Glass

Although a relatively hard material, plate glass can quite easily be scratched. Cleaning a dirty windshield when dry by operation of the wiper blade or with dry cloths is apt to cause minute surface scratches that will increase eye strain. Wet or moisten glass before cleaning.

## Care of Chromium Plating

Owners of modern cars are aware of the advantages of chromium plating but the very ability of chromium to withstand exposure has created the impression that it requires no service attention. Actually, the finest chromium plating is subject to deterioration if neglected.

Among the more common elements that attack chromium plating are: sulphur dioxide present in the air, especially in large industrial centers, calcium chloride used on city streets to melt ice and on dirt roads to prevent dust, also the salt air of coastal territories. When plating is scratched or scuffed to the base metal, ordinary moisture becomes a damaging agent. Rust, originating at the root of a scratch will continue to spread **underneath** the plating unless attended to when it first appears.

Chromium plating is very easy to clean and frequent cleaning is all that is necessary to keep it in first-class condition. First, go over all plated surfaces with a clean cloth moistened with kerosene, follow this with a clean cloth wet with clear water and then rub dry with a soft clean cloth. The rough treatment given car bumpers is apt to damage the plating. Should rust appear, use a mild scouring compound to remove every trace of rust and prevent further oxidation by applying a coat of wax, varnish or clear lacquer over the damaged area.

## Interior

A clean car unquestionably adds to the enjoyment of motoring. In respect to personal comfort, it is particularly important that the inside of the car be kept clean. At least occasionally, the whole interior should be given a thorough vacuum cleaning.

## Cleaning Upholstery

Where the use of cleaning fluid is indicated, use Packard Fabric Cleaner or a cleaning fluid in which carbon tetrachloride is the principal ingredient. To avoid rings, work from the outside toward the center.

## Battery Acids

Battery acids will destroy upholstery if allowed to remain. Neutralize the acids as soon as possible by pouring enough household ammonia water directly on the spot to saturate the fabric as far as the acid extends. Give the ammonia water a full minute to neutralize the acid and then rinse the fabric with a wet clean cloth. Use cold water.

## Blood Stains

Rub the stain with a clean cloth wet with cold water.

## Candy or Fruit Stains

Candy stains that do not contain chocolate and all fruit stains should be rubbed with a clean cloth wet with very hot water. If chocolate is present, use lukewarm water. After drying, sponge with a clean cloth wet with cleaning fluid.

## Chewing Gum

Moisten gum with cleaning fluid and remove with a dull knife.

## Ice Cream

Rub with a clean cloth wet with very hot water. If this is not satisfactory, use a cloth wet with warm soap suds and rinse with a cloth wet with cold water. After drying, sponge with cleaning fluid.

## Lipstick

Pour cleaning fluid directly on spot and immediately after hold a clean blotter on the stain. Repeat until clean.

## Shoe Polish

For black or tan polish, use a cloth wet with cleaning fluid. If white polish cannot be brushed off, wet with cold water, allow it to dry and then brush off.

## Grease or Oil

Spots should be rubbed with a cloth wet with cleaning fluid. If a considerable amount of grease or oil is present, pour cleaning fluid on stained area and blot with clean blotters.

## Tar

Moisten with cleaning fluid and remove with dull knife. Sponge with cloth wet with cleaning fluid.

## Paints and Lacquers

Rub with a cloth wet with turpentine and then sponge with a cloth wet with cold water.

## Water Spots

Sponge the entire panel with a cloth dampened with cold water and then sponge the spots with a cloth moistened with cleaning fluid.



## Instruments and Controls

Familiarize yourself with the operation of controls and learn how to interpret the instrument readings before driving your car. The following paragraphs will help you.

**The ignition lock** is located at the lower right of the center panel. Make it a habit to withdraw key when leaving car.

**The starter button** is of the remote control type and is located at the lower left of the center panel.

**The hand throttle** is located at the lower right of the center panel.

**The foot accelerator** is of the treadle type, rubber covered and "soft" in action. The mechanical linkage has been designed to give a modulated opening of the throttle that promotes smooth operation and ease of control. Depressing the accelerator once or twice may assist in **cold** starting but will interfere seriously with **hot** starting. **Hold** accelerator in wide open position when starting a hot engine but **do not pump** the treadle.

**The light control switch** is located at the lower left of the center panel. It is of the push-pull type having three positions. Pulling out to the first notch provides parking and map reading lights, second notch city or country driving lights and third notch country driving or passing lights. There is also a foot control switch located on the toe-board to the left of the clutch pedal. With the light switch in second notch, depressing the toe-board switch raises both beams to "Country Drive" while a subsequent depression tilts both beams for city driving. In a similar manner, with the light switch in third notch, successive movements of the toe-board switch alternately tilt the left hand beam for country passing or raise it for country driving. A tell-tale light on the face of the speedometer indicates when country driving beam is in use.

**Instrument lighting** is controlled by a combination switch and rheostat located to the right of the speedometer. With the main light switch "On" instrument illumination can be regulated in small steps by turning the rheostat knob.

**The oil pressure gauge** is mounted with the temperature gauge at the right of the speedometer. This gauge does **not** indicate the quantity of oil in the engine. Normal reading is 25 to 40 at 30 miles per hour. **CAUTION**—Failure of the gauge to show pressure while engine is running indicates either a lack of oil or some derangement that should be corrected immediately to avoid serious damage to the engine.

**The water temperature gauge** is located with the oil pressure gauge at the left of the speedometer. Most efficient operating temperature is between 150 and 185 degrees. Water at sea level boils at 212 degrees.

**The ammeter** is located with the fuel gauge at the right of the speedometer. This gauge indicates whether the battery is being charged or discharged. The generator regulator is so designed that the ammeter

will be nearly at **zero** when battery is **fully charged**. To determine whether generator is charging, turn on the headlights with engine stopped. Now run engine at a speed equivalent to 30 miles per hour. If the ammeter hand now moves to "Charge" side of dial, the generator is charging.

**The gasoline gauge** with the ammeter is located at the right of the speedometer. The gauge is electrically operated and will register only when the ignition switch is "On."

**A 100 mile speedometer** is located in the center of the left instrument panel. Fuel consumption at 60 miles per hour is approximately 50 per cent greater than at 20 miles per hour.

**The windshield wiper control** is mounted on top of the panel above the ash tray. Turn the knob to start wiper and regulate its speed. **Do not pull up on the knob.**

The Packard crest plate at the center panel and the medallion in right hand panel are for installation of a radio and clock respectively.

**The rear view mirror** is eccentrically mounted on a friction type ball and socket swivel and may be adjusted for height or angle.

**Front seat adjustment** is controlled by a latch located at the left end of front seat. Nine separate positions are available. Moving the seat forward elevates the cushion and decreases the seat-back inclination to provide greater comfort and better vision for persons of small stature.

**Sun visors** are swiveled in such a manner that they can be moved to shade either the windshield or the front doors.

**Ventilating windows** of the pivot type built into the front doors of all closed body types are operated by a convenient crank. Rear quarter windows in the Sedan and Touring Sedan are also of the pivot type.

**Duplicate sets of keys** are provided with each car. One set fits the ignition and right front door locks, the other set fits the package compartment and rear trunk locks. For greater protection against car theft, lock-cylinders are not numbered. **A record of key numbers** should be made by every owner to facilitate purchase of duplicate keys from Packard dealers in event original keys are lost.

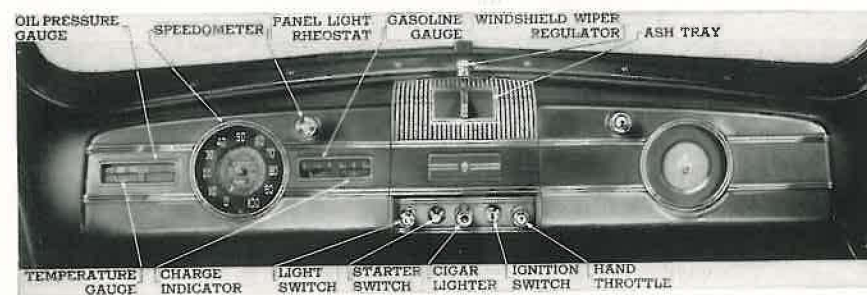

Fig. 1—Front View of Instrument Board

## Starting the Engine

All Packard cars are equipped with automatic carburetor chokes which provide proper mixture for starting and warm-up in cold weather and prevent unnecessary choking when warm. For completely satisfactory cold weather operation, Packard's lubrication recommendations must be followed:

For cold weather starting:

1. Turn on ignition switch.
2. Depress accelerator pedal once and allow it to return to the closed position. This engages the low-temperature idle control.
3. Depress clutch pedal fully.
4. Press starter button located on the instrument panel.

**NOTE:** In cold starting, should excessive choking result from failure to turn on ignition—or from any other cause—hold the accelerator pedal in the wide-open position until engine starts, but do not allow cold engine to race.

**When hot**, engines with down-draft carburetors start more readily with fully opened throttle. **Hold** accelerator in wide-open position until engine starts. **Do not pump** accelerator pedal.

## Carbon Monoxide Gas

Open garage doors wide before starting the engine. Poisonous carbon monoxide gas is present in the exhaust of all gasoline engines. Don't take chances—provide lots of fresh air.

## Owner's Maintenance Schedule

Adherence to this chronological maintenance schedule will be found very helpful in securing uninterrupted and pleasurable use of your car. Although not listed, owner should have the chassis lubricated every 5,000 miles.

### *Every Week*

#### Tires

Check air pressure and inflate to specifications. Page 3.

### *Once a Month or Every 2,000 Miles*

#### Battery

In the case of HiLevel batteries, distilled water (rain water in an emergency) should be added to each cell until the star disappears.

#### Oil Bath Air Cleaner

Should be cleaned and proper amount of new S. A. E. 30 or S. A. E. 50 oil added at intervals of not more than 5,000 miles. Page No. 27.

#### Engine Lubrication

See "When Should Oil be Changed" on next page.

### *Twice a Year*

#### Cooling System

The cooling system should be reverse flushed twice a year. Page No. 24.

#### Shock Absorbers

Check for proper oil level and refill, if necessary, with Packard Hou-daille Shock Absorber Fluid. Other fluids may change the ride characteristics.

#### Brakes

Master cylinder fluid level should be checked twice a year at least, or whenever pedal goes all the way to the floor. Use Packard Special Brake Fluid or, if not available, Lockheed No. 5 Fluid. Page No. 47.

#### Engine Tune-Up

In the spring and fall, the engine should be completely tuned which will include a check of the carburetor and ignition system.

#### General Tightening

The car should be given a "general tightening" occasionally, especially if driven over rough roads, to keep it free of rattles.

### *Once a Year*

#### Rear Axle

Lubricant must be changed in advance of cold weather. Use only Packard Approved Lubricants. **This is important.**

#### Transmission

The lubricant should be changed in the spring.

#### Front Wheel Alignment

Check to assure easy steering and long tire life. Page No. 40.

#### Engine Oil Pan and Filter

Remove and thoroughly clean pan and oil pump strainer screen. External filter should be renewed every 8,000 miles.

## General Lubrication

The subject of lubrication of the complete automobile should be given careful attention. It is important that the lubrication schedule be followed and that the proper lubricant be used if the car is to give quiet and efficient performance. The use of high grade lubricants will prolong the life of the wearing parts and prove most economical in the long run.

It is now common practice of oil companies to designate their oil by the S. A. E. classification, instead of the old method of designation as light, medium or heavy. The application of the S. A. E. viscosity number to a lubricant is intended only to indicate the body or fluidity of the oil and has no bearing on the quality of the product. Only high quality oils furnished by reputable companies should be used and for accuracy they should be ordered by S. A. E. numbers.

It is essential to add oil, as required, to maintain the correct oil level.

Choose the proper viscosity from the following table in accordance with the lowest temperature expected to be encountered.

### Engine Oil Viscosity

Below minus 10°F.....	10-W plus 10% kerosene
Minus 10°F.....	10-W
Plus 10°F.....	20-W
32°F.....	S. A. E. 30
90°F. average daylight temperature....	S. A. E. 40

The best performance of the engine will be obtained by using the correct body (S. A. E. number) of engine oil in the engine crankcase as specified in the above table. The oil should be of a low S. A. E. number in cold weather to provide proper starting and a higher number in warm weather to provide economical consumption.

### When Should Oil Be Changed

The engine oil should be changed in accordance with temperature variations rather than according to seasons. In some localities variations in temperature are so extreme that several grades may be required during the course of a year.

Low maintenance costs, long engine life and best performance will be insured by changing the crankcase oil when it becomes contaminated. Driving over dusty roads or through dust storms with dirt-clogged air cleaners, introduces abrasive material in the crankcase. If this is not removed immediately by draining the crankcase, harmful engine wear may result.

Hard driving in warm weather causes chemical changes in the oil. Accumulation of the products of these changes is undesirable and may prove harmful to the engine.

In winter, water accumulates in the crankcase from condensation of moisture produced by the burning of the fuel and may freeze and interfere with proper oil circulation. It also promotes rusting and causes clogging

of oil screens and passages. While on long continuous drives this water may be removed by the crankcase ventilator, draining is a safer procedure. Light oils should be used for easy starting but very hard driving may thicken them and cause starting trouble.

Obviously the time between crankcase drains depends entirely upon the driving conditions. In considering the above factors as to when to change the oil it should be kept in mind that good lubrication is cheap insurance against high maintenance costs.

The first change should be made at low mileage, thereafter, 2,000 to 3,000 mile changes are recommended as that most closely approximating average conditions, but the changes should be controlled by the driving conditions pointed out above.

### Engine Oil Pan and Filter

To prevent the accumulation of sludge which is injurious to the engine, the lower oil pan and screen should be removed and cleaned at least once a year.

The external oil filter on left side of engine should be renewed every 8,000 miles—in no case should it be used beyond 10,000 miles.

### Clutch Shifter Bearing

The clutch shifter thrust bearing is packed with lubricant and sealed and should not require attention. Should bearing become noisy, a hand oiler with long curved nozzle may be used to reach the well in bearing housing after removing the steel pan at bottom of bell housing. A teaspoonful of oil is sufficient for one oiling. Do not overoil.

### Clutch and Brake Pedals

The clutch and brake pedal bearings are lubricated by a single pressure gun fitting.

### Universal Joints

The roller bearing type universal joint journals are packed with lubricant and sealed. Every 30,000 miles the joints should be taken apart, repacked and new cork seals installed. Lubricate slip yoke spline with pressure gun every 5,000 miles.

### Rear Axle

Oil should be changed in the fall. A special rear axle gear oil is necessary for hypoid gears and the use of alternate lubricants may ruin the gear set. See Packard Dealer for approved lubricant.

### Rear Wheel Bearings

Unless a leak develops at the oil seals, bearings will not require lubrication for at least 30,000 miles. At this mileage the shafts should be removed and the bearings packed with No. 3 fibre grease. Renew any leaking seals.

## Steering Gear and Transmission

The oil level in the transmission should be checked at every 5,000 mile greasing operation to make certain oil level is up to filler opening. Use S. A. E. 160. Dilute with kerosene or change to S. A. E. 90 for winter if desired. Change oil in spring.

Follow same directions on steering gear.

## Distributor

Refill and turn grease cup every 5,000 miles. Apply one drop of oil to the breaker arm pivot, a few drops to the wick under the rotor and a small amount of vaseline to the breaker cam.

## Lubrication Schedule

### 5000 Miles

Knuckle pins	Pressure gun grease	2 lubrication connections
Steering connecting rod	Pressure gun grease	2 lubrication connections
Steering cross tubes	Pressure gun grease	4 lubrication connections
Universal yoke spline	Pressure gun grease	1 lubrication connection
Water pump shaft	S. A. E. 30 or 20-W	1 oiler
Generator	S. A. E. 30 or 20-W	2 oilers
Starter motor	S. A. E. 30 or 20-W	2 oilers
Distributor	No. 3 cup grease	Refill cup and turn
Clutch and brake pedal	Pressure gun grease	1 lubrication connection

Add a few drops of light oil to the clevis pins, door hinges, dovetails and locks. Grease hood lacing and hinges as needed.

Crankcase—refer to "When Should Oil be Changed" on page 18.

### 10,000 Miles

Support arm outer pin	Pressure gun grease	2 lubrication connections
Front wheel bearings	Fibre grease	(2) Repack
Transmission	S. A. E. 160—Dilute with kerosene or use S. A. E. 90 for winter if desired.	Fill to level
Steering gear	Same as transmission	Fill to level
Rear axle	See note	Drain and refill

NOTE: Rear axle gears require a special lubricant, see Packard dealer.

### 30,000 Miles

Rear wheel bearings	No. 3 fibre grease	(2) Repack
Universal journals	S. A. E. 160	(8) Repack

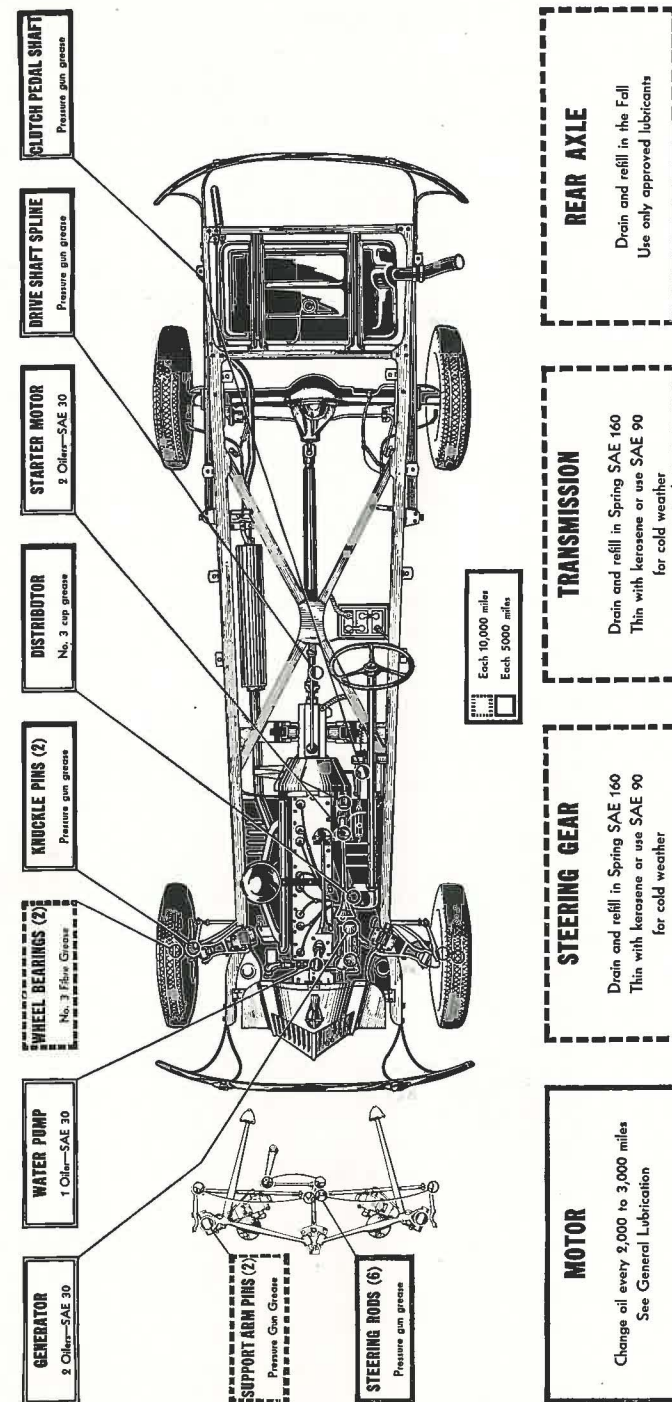

Fig. 2—Lubrication Chart Showing Points to Lubricate and Type of Lubricant Needed

## Engine

Cylinders and upper crankcase are cast as an integral unit from an iron alloy of high wear resistance. The heat treated aluminum alloy cylinder head is attached to the top face of the block by means of studs. Valves are actuated by pressure lubricated mushroom type lifters operating directly in guide holes machined in the block. The camshaft is driven by a non-adjustable silent chain at the forward end of the engine. Compression ratio 6.6 standard, 7.05 optional.

### Pistons and Rods

Piston and connecting rod assemblies can only be removed from the top of the block. When re-installing assemblies, make certain the connecting rod oil squirt holes and piston slots are on the camshaft side of the engine. To avoid possible injury to piston bosses, pistons should be heated to approximately 160°F. before dismantling from connecting rods and when fitting new piston pins.

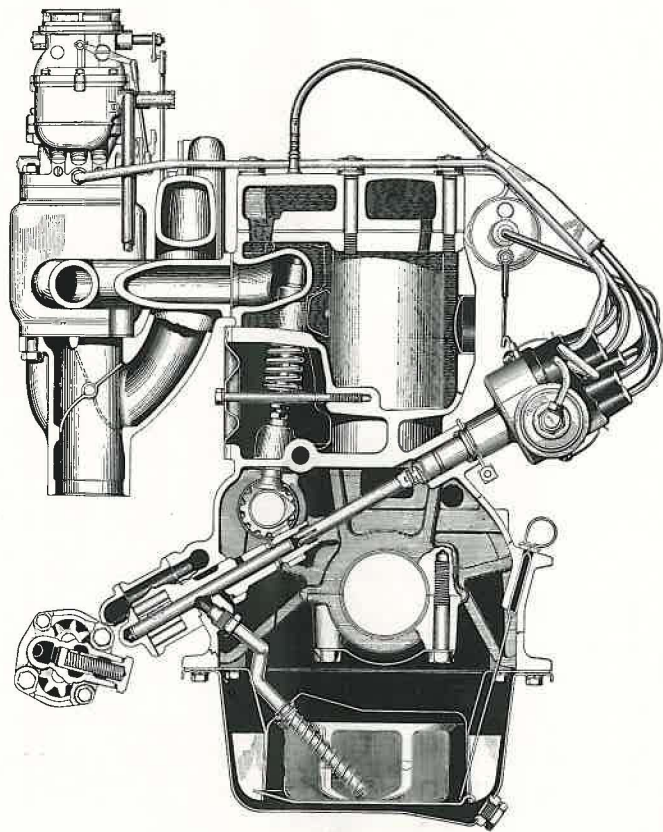

Fig. 3—Details of Oil Pump and Pressure Relief Valve and Distributor Drive. Valve Keepers are Slot and Key Type

### Bearings

The camshaft, crankshaft and connecting rod bearings are all of the shimless, precision, steel backed, babbitt lined type. They are non-adjustable and should be renewed whenever inspection shows excessive clearance. Crankshaft bearing upper and lower halves may be renewed from below without removing the crankshaft. Connecting rod bearings may be renewed from below without removing the rod or piston.

### Valve Tappets

Recommended valve stem to tappet clearance is .007 inch for the inlet and .010 inch for the exhaust with engine warm and running.

### Valve Timing

Exhaust valve should just close 5° or 2½ flywheel graduations after top center with tappet set to .015". The "O" marks on sprockets should be together and aligned through shaft centers.

### Oil Filter

A by-pass type two-stage filter of improved design is attached to the left side of engine near the front. The filter removes dirt particles that are too small to be caught by the pump screen and due to its second stage cellulose element restores the oil to nearly its original color. Outlet side of the unit supplies clean oil under pressure to the tappets, provided the cartridge is renewed at the recommended intervals. Filter cartridge should preferably be renewed every 8,000 miles—in no case should it be used beyond 10,000 miles.

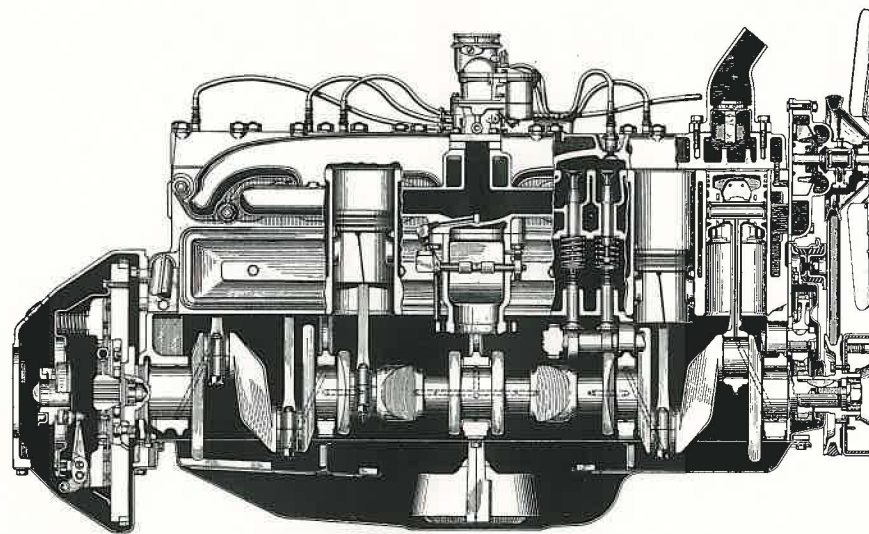

Fig. 4—Side Section of Engine and Clutch Assembly

## Cooling System

Drainage facilities are provided by a drain plug at rear end of cylinder block and a valve in the radiator lower outlet casting. Both must be opened to empty the block and radiator core.

The cooling system should be reverse flushed each spring and fall and always before adding anti-freeze, to remove a probable accumulation of rust particles and sediment. Seven ounces of soluble oil added after flushing will delay subsequent accumulation of rust.

**Caution:** Never use caustic alkali radiator cleaning preparations as they have a definitely detrimental effect on the aluminum alloy cylinder head.

### Anti-Freeze Solutions

Anti-freeze solutions of alcohol and water, ethylene glycol and water, or glycerine and water may be used. While alcohol solutions have a lower boiling point than water and are subject to evaporation, there is less tendency to spark knock. The hazard of injuring the car finish with alcohol is reduced by the location of the radiator filler under the bonnet. When alcohol solutions are used, seven ounces of soluble oil should be added as a rust inhibitor. A good grade of soluble oil is obtainable from Packard Dealers. Ethylene glycol (Prestone) and glycerine (G. P. A.) contain soluble oil and therefore none need be added. Trade marked anti-freezes are also often sold mixed with water and rust inhibitors. When these are used, follow directions on the containers.

Do not save Prestone from one winter to the next. Use new material each year.

It is advisable to shellac the inside of the hose connections when ethylene glycol or glycerine is used, as otherwise there may be a tendency to seep at the joints.

The table below indicates quantity, in quarts, of anti-freeze required for protection in the range from 20° above zero to 30° below zero Fahrenheit. Quantities shown are based on a system capacity of 16 quarts.

Pure Methyl Alcohol	Denatured Alcohol	Prestone (E. Glycol)	Radiator Glycerine	Freezing Point Approximate
2.0	3.0	2.5	6.0	20° F. Above zero
3.0	4.5	4.0	9.0	10° F. Above zero
4.5	5.5	5.0	11.0	Zero
5.0	6.5	6.5	13.0	10° F. Below zero
6.0	7.5	7.0	15.0	20° F. Below zero
6.5	8.5	7.5	16.0	30° F. Below zero

**NOTE:** During the cold weather months have the radiator solution tested occasionally with an hydrometer, especially prior to an expected drop in temperature. This practice may avoid expensive repairs.

**Caution:** Do not use a calcium chloride or an alkaline solution or any anti-freeze compounded from these materials. Such solutions will surely corrode the aluminum alloy cylinder head and the radiator core and are liable to clog the cooling system.

## Fan Belt Adjustment

Adherence to recommended tension specifications is important. Premature failure of either the belt or the pump and generator bearings results from too little or too much belt tension. Adjust the belt by first loosening the two generator pivot bolts, also the hinge bolt and lock bolt on adjusting link. Hook a spring scale to the bolt passing through the generator lug and pull in line with the link until scale pointer registers 25 lbs., as shown in Fig. 5. Holding this position, tighten the four bolts. If a scale is not available, adjust belt tension to provide one-half inch of thumb pressure deflection between generator and water pump pulleys.

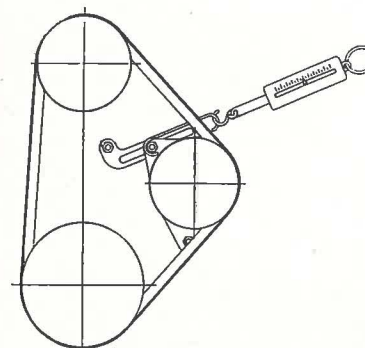

Fig. 5 (Left)—Belt Tension Should be Adjusted to 25 Pounds Scale Pull or 1/2" Thumb Pressure Deflection

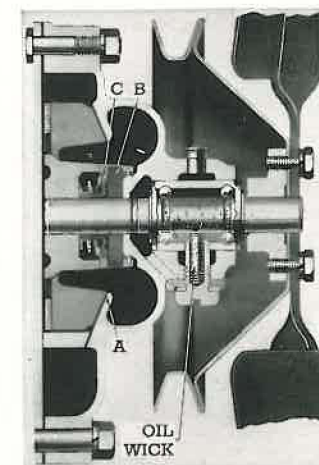

Fig. 6 (Right)—Water Pump is of the Packless Type Utilizing a Spring Loaded Sealing Element

### Water Pump and Shutters

Pump unit is of the so-called "packless" type employing a spring loaded sleeve type rubber seal and a composition thrust washer, Fig. 6. Flip type oiler should be filled at intervals of 5,000 miles. If pump leaks remove the assembly and renew the sealing element or install an exchange factory rebuilt unit.

Thermostatically operated shutters start to open at 150° Fahr. and should attain maximum opening at 165°. They require no owner attention.

### Notes for the Mechanic

To avoid breakage, pump body should be supported when pressing impellor off shaft. Installation will be facilitated by heating impellor in water just under boiling point. Clearance between impellor and housing at "A" should be .030 to .050 inch. Both gaskets should be coated with Perfect Seal grade A paste or equivalent. When installing the composition thrust washer be sure that convex face of washer is nearest the fan blades.

## Fuel System

### Combination Fuel and Vacuum Pump

Details of the combination fuel and vacuum booster pump are illustrated in Fig. 7. It is mounted on the right side of the engine near the cooling fan and is exposed to the relative air flow to reduce vapor lock. The vacuum pump portion of the assembly acts as a stabilizing booster for the windshield wipers by providing sufficient vacuum to operate the wiper blades under all driving conditions. Owner care of the assembly should be confined to spring and fall cleaning of the pump screen. Any trouble should be referred to an authorized Packard or A.C. service station.

**Note:** Excessive engine oil consumption is frequently traceable to a leaky vacuum pump diaphragm permitting oil to be sucked from the crankcase into inlet manifold. To determine if defective vacuum diaphragm is causing high oil consumption, disconnect the manifold to vacuum pump line at the pump end. If inside of line is oily or if oil vapor is ejected from pump opening with engine running at high speed, diaphragm is defective and should be replaced.

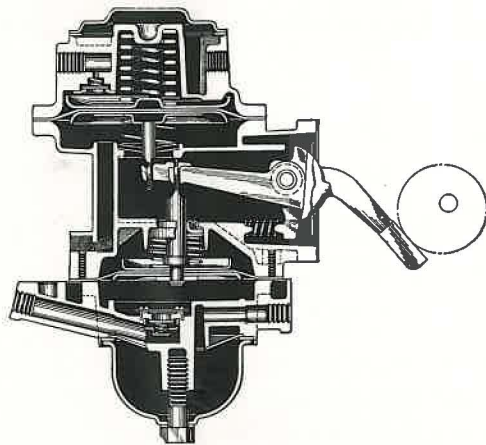

Fig. 7—Fuel and Vacuum Pump Assembly. Note that Vacuum Unit is at Top

### Fuel Gauge

This is an electrically actuated gauge mounted on the instrument panel and connected to the float and electrical resistance unit located in the gasoline tank. It utilizes current from the car battery and functions only when the ignition switch is turned on.

**Note:** Derangement of the gauge is generally traceable to a broken wire, poorly grounded tank or gauge unit or a burned out tank unit. Loose mounting screws, paint under the screw heads or lack of intimate contact between tank and chassis frame are frequent causes of an inadequately grounded circuit.

## Air Cleaner and Silencer

Under ordinary conditions, the unit should be cleaned and refilled every 5,000 miles, or as often as every day where all of the driving is done on extremely dusty roads. Definite mileage intervals cannot be stated due to the natural variation in conditions. The safe procedure in very dusty territory is to check the unit daily and clean if necessary.

Procedure for cleaning is as follows: Dismount the assembly from the carburetor, then remove the filter element and the oil reservoir. Wash the filter element by plunging it up and down several times in a vessel of clean gasoline or kerosene. Do not oil the filter element as this is automatically oiled in operation. Empty the oil reservoir and clean thoroughly, then refill to level with a pint of S. A. E. 50 engine oil in summer, or S. A. E. 30 in winter.

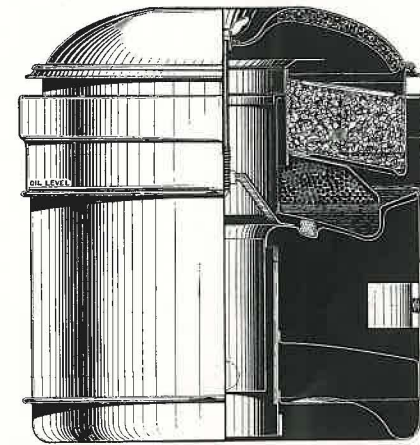

Fig. 8—Carburetor Air Cleaner is of the Oil Bath Type

### Crankcase Ventilation

Air inlet for the crankcase ventilation system is through the oil filler tube. The cap of this filler tube is fitted with a copper mesh type of air cleaner to prevent dust from entering the crankcase. The cap filter element should be cleaned every 2,000 miles or oftener by plunging up and down in a container of clean gasoline or kerosene. Allow filter to dry, then saturate with S. A. E. 50 engine oil and reinstall.

### Heat Control

Amount of exhaust gas heat applied to the inlet manifold is automatically controlled by a thermostatic spring on the outside of the heat riser operating a counter-weighted valve inside the riser as shown at the center of illustration in Fig. 4. The heat control valve requires no attention except occasional inspection to make **sure** that it moves freely when turned by hand. No part of the control should ever be oiled.

## Carburetor and Choke

The Stromberg carburetor is of the duplex plain tube type with fixed main metering orifices, a mechanically controlled power mixture or economizer valve and a built-in piston for operation of the automatic choke. Cut away views of the instrument are shown in Fig. 9. Only the idle mixture is manually adjustable.

### Idle Adjustment

Idle mixture adjustment is controlled by the two knurled needle valves, "23," one of which is shown near the base of the carburetor. One of these needles controls the quantity of idle mixture delivered to the center four cylinders. The other one controls cylinders 1, 2, 7 and 8. To adjust the idle, first set the throttle stop screw to 6 M. P. H. car speed with engine warm. Turn one of the needles in, until engine runs irregularly, then out until engine begins to "roll," then in again, slowly, until smoothest running is obtained. Do the same with the other needle.

### Fuel Level

Recommended fuel level is  $\frac{15}{32}$ " plus or minus  $\frac{1}{32}$ " below machined top surface of float bowl with  $2\frac{1}{2}$  to 3 lbs. pressure on fuel.

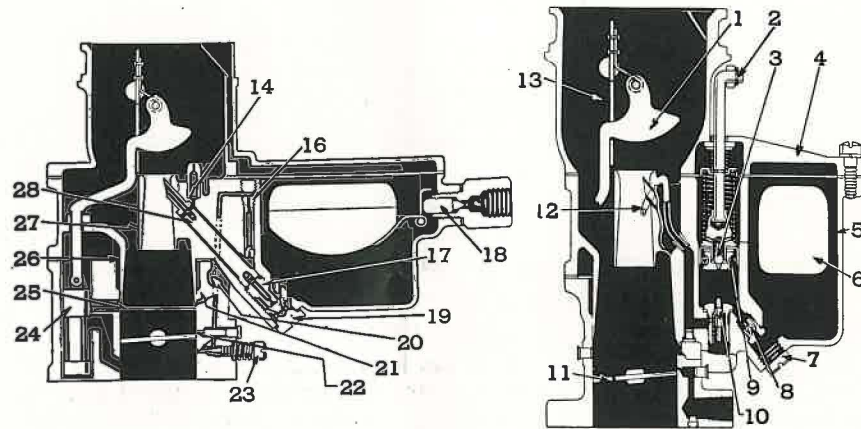

Fig. 9—Schematic Views of Packard Stromberg Carburetor

- |                       |                      |                                  |
|-----------------------|----------------------|----------------------------------|
| 1. Vacuum Piston Link | 11. Throttle Valve   | 21. Lower Body                   |
| 2. Pump Piston Link   | 12. Pump Nozzle      | 22. Idle Disch. Ports            |
| 3. Pump Relief Valve  | 13. Choke Valve      | 23. Idle Adj. Needle             |
| 4. Air Horn           | 14. Main Air Bleeder | 24. Vacuum Piston                |
| 5. Float Chamber      | 15. Idle Tube        | 25. Cold Idle Passage            |
| 6. Float              | 16. Metering Jet     | 26. Primary Venturi              |
| 7. Check Valve Cap    | 17. Float Needle     | 27. Auxiliary Venturi            |
| 8. Pump Check Valve   | 18. Metering Jet Cap | 28. Main Discharge Jet or Nozzle |
| 9. Pump Piston        | 19. Idle Passage     |                                  |
| 10. Economizer Valve  |                      |                                  |

## Choke Adjustment

Ordinarily the choke will require no adjustment throughout its life. However if a check of the warm-up behavior shows definitely that the carburetor mixture is either too lean or too rich during this period, proceed as follows:

1. Disconnect link "G," Fig. 10, and test operation of choke valve. When closed by hand, it should drop open freely without the slightest lag. If it does not drop freely, remove choke valve and shaft and clean with alcohol or crocus cloth. Make sure that fly (disk) does not bind in air horn. CAUTION: Do not oil any part of the choke linkage.

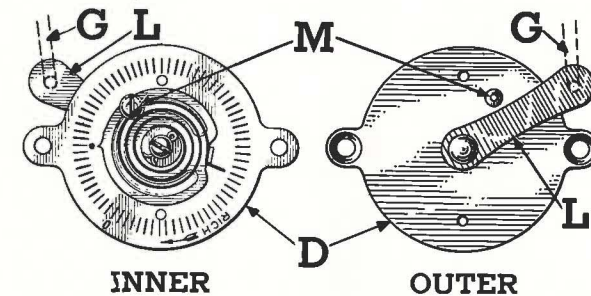

Fig. 10—Right Hand View Shows Thermostat Unit as it Appears when Installed. Left View Shows Inner Face of the Unit with Thermostat Spring Adjusted to Factory Setting

2. Remove thermostat assembly "D" from exhaust manifold and check the adjustment of the thermostat spring. Factory adjustment is when the arrow on prong plate is aligned with the stamped 11th graduation (in the "rich" direction) from the "0" or zero mark on main plate, as shown in Fig. 10. If arrow is not so aligned, turn screw "M" to secure this position.

Correct any bearing friction in movement of piston "24," Fig. 9, and lever "L," Fig. 10, and reinstall assembly to manifold.

3. Adjust link "G" so that lever "L" is  $\frac{1}{16}$ " away from combination stop pin and adjustment screw "M" when choke valve is fully closed.

4. If mixture is still too rich or too lean during warm-up period, remove thermostat assembly and decrease or increase the spring tension one graduation at a time. Satisfactory results should be obtained by changing the adjustment not more than 5 graduations from the original setting of 11 graduations rich. If results are not obtained within these limits, the thermostat is distorted and should be replaced.

## Notes for the Mechanic

To determine if carburetor economizer is leaking remove the air cleaner, place a light over the air horn and observe the pump nozzle "12," Fig. 9. If any mixture is being delivered from this nozzle when the engine is running at 30 to 35 M. P. H., the valve is leaking and should be corrected.



## Electrical System

The electrical system is of the single wire or grounded return type. The positive battery cable is grounded to the frame and the negative wire connects the battery with the starter motor.

The battery is located in a protected cradle under the front seat and can be serviced easily by removing the cushion and floor plate.

The electro-lite in the battery should always be maintained at the proper level. Distilled water, or if not available, rain water, should be added to each battery cell until the star in filler opening disappears. Use a hydrometer to gauge the condition of the battery. A fully charged standard equipment Hi Level battery should register 1250 specific gravity. It is important that the battery be kept firmly anchored in its cradle; if it works loose, broken cells and loose connections result.

### Generator

The AutoLite GCJ 4807-A2 generator is air-cooled by means of a fan on the generator pulley which permits a high charging rate without danger of burning the armature. Current control is by means of an adjustable third brush while voltage control is by means of an external regulator mounted on the dash. The maximum output is 25.5 amperes at 8 volts with a hot generator, regulator disconnected and field terminal grounded. Do not run the engine with the generator or battery wire disconnected, as this usually results in a damaged instrument, burnt-out bulbs or a run-down battery. The commutator should be kept clean, smooth and dry. If it appears dirty or rough, clean with 00 sandpaper. Never use emery cloth for this purpose. The brushes should move freely in their holders and full contact area should bear on the commutator.

### Starting Motor

The Auto-Lite MAX 4006 starting motor is fitted to the front face of the flywheel housing on the left side of the engine. It is controlled by a magnetic relay switch on top of the starting motor, operated by a remote button on the instrument board. The starter is equipped with a Bendix shifting mechanism, the pinion of which engages with a steel ring gear shrunk on the flywheel.

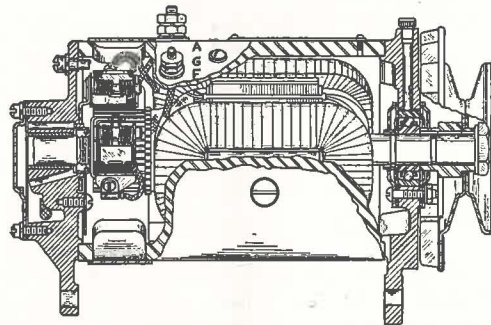

Fig. 11—Generator Current Control is by Means of an Adjustable Third Brush

### Starter Drive

Proper cleaning and lubrication of the Bendix drive is important. If the screw shaft becomes gummy, clean with kerosene and lubricate the threads with light engine oil. Do not use gasoline for cleaning as it is very likely to destroy the special packed-in lubricant. A light film of graphite grease should be applied to the shaft where the pinion travels.

### Manual Control of Starter Switch

In case the remote control on the instrument board fails to operate the starter, due to a broken switch or defective contacts, the main switch contact can be made by removing the cap at the rear end of the magnetic switch on starter and pressing the plunger underneath. This is also a convenient method for turning the engine when adjusting in the shop.

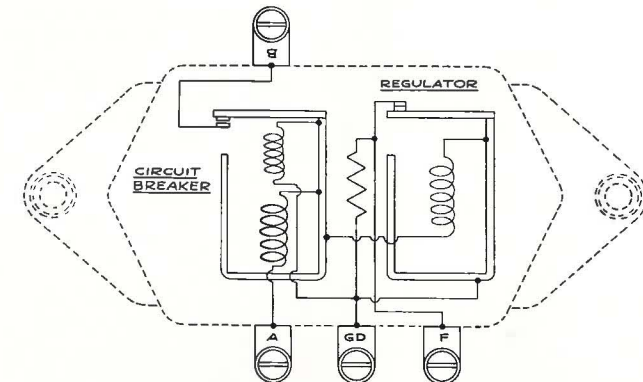

Internal Circuits of the Voltage Regulator and Cut-out Relay Units. Assembly is Mounted on Engine Side of Dash

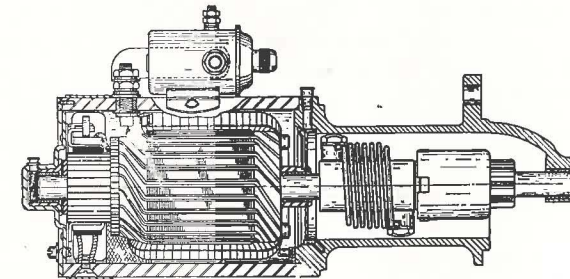

Fig. 12—Starter may be Operated From Engine Compartment by Pressing the Plunger Under the Cap of the Magnetic Switch on Top of Starting Motor

### Horns

The horns are mounted on the engine and operated by a relay attached to the horn bracket. This relay insures long life to the horn button contacts. To remove the horn button, press down, rotate either to the right or left and lift out.

## Fuses and Circuit Breaker

A thermostatic type of overload relay or circuit breaker is attached to the lower side of the lighting switch shown in Fig. 13. It protects the headlamp wiring circuit in case of overload or short circuit.

Two 20 ampere fuses mounted in clips on the switch frame protect the dome light and accessories circuit (cigar lighter, heater, etc.) respectively, and a similar fuse enclosed in a socket in the tail lamp line near the light switch acts as a safeguard for the tail lamp circuit. If the tail lamp fuse blows, the instrument light is extinguished.

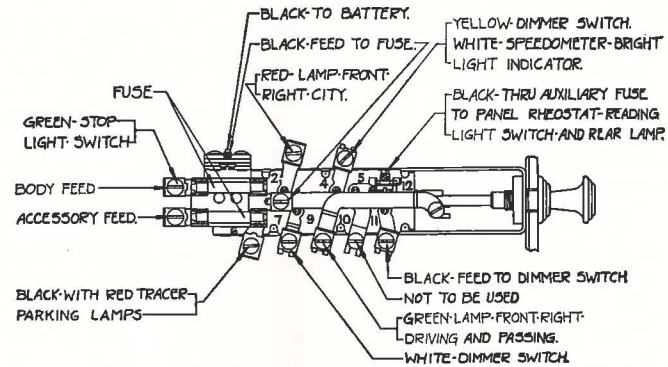
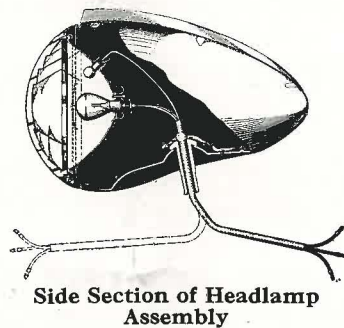

Fig. 13—Lighting Switch Carries the Thermostatic Overload Relay and Fuses for the Dome Light and Accessory Circuits



## Lamps and Reflectors

The Flex-beam headlamps have prefocused main bulbs. To remove lens and door assembly turn door screw to the left until released then lift up and off. The lenses are marked right and left and if removed for any reason should be reinstalled as indicated.

To clean lamp reflectors, use lamp-black and polish from the center to the edge. Do not use a circular motion.

## Lamp Beam Adjustment

With car fully loaded and tires inflated, place it on a level floor within twenty-five feet of a white screen or wall.

Measure the height of lamp centers above floor level and stretch a ribbon across the screen at this height. By sighting through the exact center of the rear window, and the radiator cap, determine a point on the screen corresponding to the center line of the car. Measure the distance between the centers of the lamps and place vertical markers at half this distance on either side of the center line. A typical screen layout with the ribbons indicated by the one horizontal and three vertical lines is shown in Fig. 14.

Cover the right lamp, place switch on "country drive" position, then aim the spot of high intensity "H.I.L." from the left lamp so that it centers on the corresponding lamp center marker with its upper cut-off falling at the horizontal marker as shown. Tighten mounting nut securely while lamp is in this position.

Now cover the left lamp and aim the right lamp until the left margin of the spot of high intensity "H.I.R." falls on the right center marker and the upper cut-off on the horizontal ribbon as shown in view one. With headlamps tightened in these positions, the "city driving" and "country passing" beams will automatically fall in their proper places as indicated in views 2 and 3 respectively. If the lighting in "country passing" position appears to be too blinding for oncoming traffic, turn right hand lamp slightly toward the curb.

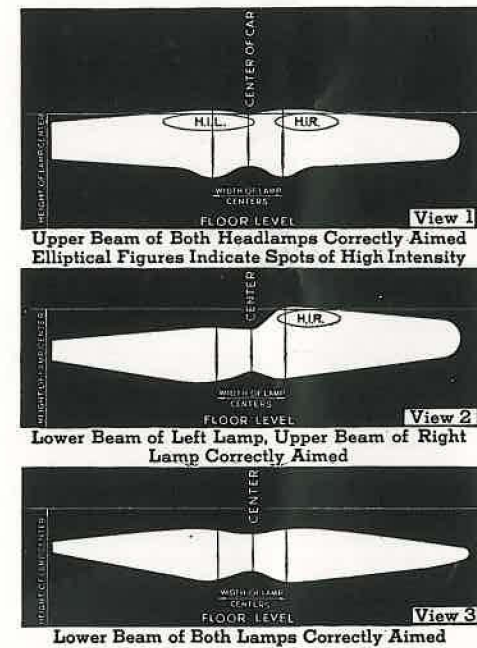

Fig. 14—Headlight Patterns Secured at Various Switch Positions

## Ignition Distributor

The distributor shown in Fig. 15 is of the full automatic advance single breaker type employing a centrifugal governor and manifold vacuum for timing control. The centrifugal governor advances the spark as the speed of the engine is increased. The vacuum advance mechanism being connected to the inlet manifold at the carburetor throttle advances the spark according to the power load imposed on the engine. The vacuum advance is additional to that provided by the governor thereby reducing fuel consumption by advancing the spark at part throttle operation.

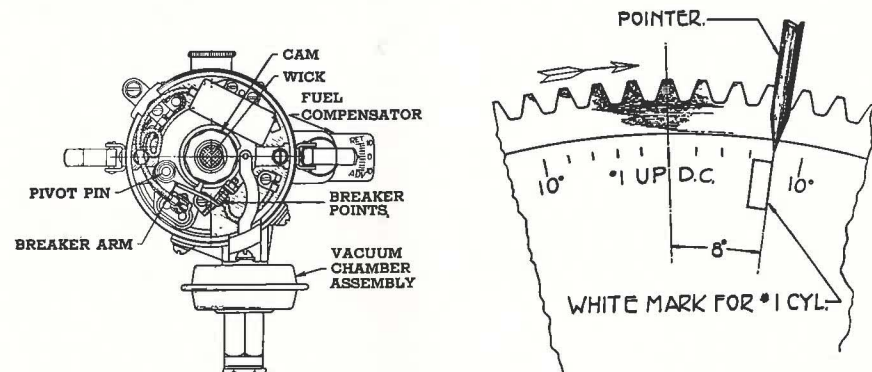

Fig. 15 (Left)—Top View of Single Breaker Distributor Showing Vacuum Modifier Unit and Fuel Compensator

Fig. 16 (Right)—Front View of Flywheel Showing 8 Degree Mark for Timing Standard Heads

The distributor is provided with a graduated advance arm called the fuel compensator which permits a quick manual change from the standard timing to eliminate the pinging of low octane fuels.

## Ignition Timing

Regardless of the method used make sure that the breaker points are clean, aligned with each other and adjusted to a gap of .015" before retiming. With fuel compensator set at zero as shown in Fig. 15, spark should occur in No. 1 cylinder  $6\frac{1}{2}^{\circ}$  to  $8^{\circ}$  or 3 to 4 graduations on the flywheel before top center. Flywheel mark "UDC1" indicates top center. Use inspection hole in housing below the starter motor. Refer to Fig. 16. The firing order is 1-6-2-5-8-3-7-4.

NOTE: Engines with special 7.05 to 1 head should be timed  $2\frac{1}{2}^{\circ}$  to  $4^{\circ}$  before top center.

## Distributor Test Data

Test specifications of the Auto-Lite IGT-4007 distributor are: Breaker point spring tension 19 to 23 ounces. Governor advance starts at 300 distributor R. P. M.;  $4^{\circ}$  at 800 R. P. M. and attains a maximum of  $8\frac{3}{4}$  distributor degrees at 2000 distributor R. P. M. These specifications should be obtained with vacuum advance disconnected. A variation of  $\frac{3}{4}$  of a degree above or below these figures is allowable. The vacuum

advance starts with vacuum of 6 to 7 inches of mercury and attains a maximum of 7.5 distributor degrees at 17 inches vacuum.

## Ignition Coil

The ignition switch is mounted on the instrument board and connected to the coil by a cable encased in a metal conduit. When the switch is turned "off" the circuit is broken through the coil, grounding the coil and making it impossible to start the engine by wiring around the switch. The switch is protected by a cylindrical type lock for which two keys are supplied. Amperage draw of coil is  $2\frac{1}{2}$  amperes engine stopped.

## Spark Plugs

Spark plugs are 10 mm. AC model 103 or Champion Y-4. To prevent damage to the plugs they should be installed using the wrench provided in the tool kit. Only one hand should be used on the wrench when tightening. If the regular tool kit wrench is not available, the leverage used should be limited to that obtainable with one hand on a wrench handle  $\frac{1}{4}$ " diameter—not more than  $4\frac{1}{2}$ " long overall. Stated in another manner, the leverage should not exceed 50 inch lbs., that is, not more than 10 lbs. pull on a wrench handle of 5 inches effective length. Refer to Fig. 17.

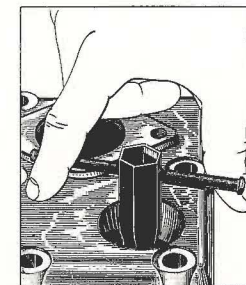

The spark plug gap should be .028" + or - .002" for all cars. In readjusting the gap bend the side electrode—never bend the center electrode as this may crack or break the insulator.

Fig. 17—Thumb and Finger Leverage is Sufficient to Tighten the 10 mm. Spark Plugs

## Light Bulbs

Location	Candle-power	Mazda No.
Front lamp	32-32	2330-L
Front parking lamp	$1\frac{1}{2}$	55
Front fender lamp	$1\frac{1}{2}$	55
Instrument board panel light	$1\frac{1}{2}$	55
Instrument board clock light	$1\frac{1}{2}$	55
Instrument board reading light	$1\frac{1}{2}$	55
Instrument board signal light	0.8	51
Rear stop and tail lamp (two filaments)	21-3	1158
Instrument board radio control lamp	$1\frac{1}{2}$	55
Dome light	6	81
Heater indicator	0.8	51
Fog light	32	1321
License plate lamp	3	63

NO	COLOR	LOCATION	NO	COLOR	LOCATION
1	RED	FROM STARTER MOTOR SWITCH TO GENERATOR	3	BLACK	FROM IGNITION SWITCH TO GASOLINE GAUGE
3A	RED	FROM CURRENT REGULATOR TO GENERATOR	14	RED	FROM LIGHTING SW. TO LAMP FRONT RT. (C17)
3B	BLACK	FROM CURRENT REGULATOR TO AMMETER	15A	WHITE	FROM DIMMER SW. TO LAMP FRONT LT. (C18)
3C	BLACK	FROM IGNITION SWITCH TO AMMETER	15B	WHITE	FROM DIMMER SW. TO LIGHTING SWITCH
5	BLACK	FROM LIGHTING SWITCH TO DIMMER SWITCH	16	GREEN	FROM LIGHTING SW. TO LAMP FRONT RT. (C17)
6A	YELLOW	FROM DIMMER SWITCH TO LAMP FRONT LT. (C18)	17	BLACK WITH RED TRAC.	FROM LIGHTING SW. TO LAMP FRONT LT. (C18)
6B	YELLOW	FROM DIMMER SWITCH TO LIGHTING SWITCH	18	BLACK	FROM IGNITION SWITCH TO CURRENT REGULATOR (C19)
7A	BLACK	FROM STARTER BUTT. TO IGNITION SWITCH	19	BLACK	FROM STEERING POST (HORN BELL) TO HORN REL.
7B	BLACK	FROM STARTER BUTT. TO LIGHTING SWITCH	20	BLACK	FROM STEERING POST (HORN BELL) TO HORN REL.
8A	BLACK	FROM PANEL RHESIST. TO FUSE TO LIGHT SW	24	BROWN	FROM VOLTAGE REGULATOR TO GENERATOR
8B	BLACK	FROM PANEL RHESIST. TO REAR LAMPS	25	WHITE	FROM LIGHTING SW. TO SPEEDOMETER LIGHT (D)
9A	BLACK	FROM RR. HARNESS JN. TO STOP LIGHT SW			
9A	GREEN	FROM FUSE AT LIGHTING SW. TO STOP LIGHT SW			
9C	BLACK	FROM RR. HARNESS JN. TO STOP LIGHT SW			
9C	GREEN	FROM RR. HARNESS JN. TO GAS. TANK GAUGE			
11A	RED	FROM RR. HARNESS JN. TO GAS. TANK GAUGE			
11B	RED	FROM RR. HARNESS JN. TO GAS. TANK GAUGE			

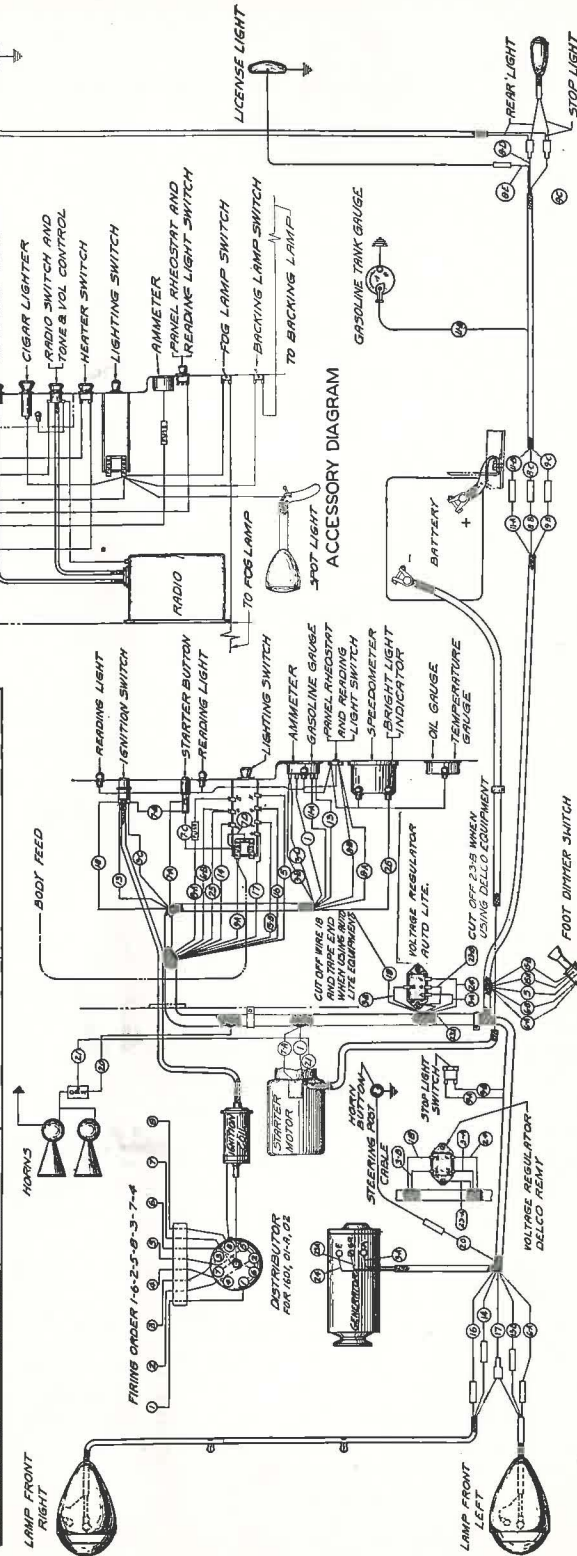

Fig. 18—Chassis Wiring Diagram. Does Not Include Body Wiring

# Clutch and Transmission

The only external adjustment of the semi-centrifugal clutch is at the pedal linkage shown in Fig. 19. Pedal should have 1½ inches of free travel measured between pedal pad and floor board. Adjust by means of the nut and lock nut "D" on the pedal adjusting rod shown in Fig. 19. Internal details of the 3-speed, synchro-mesh helical gear transmission are shown in Fig. 20. Lubricant capacity is one quart or two pounds.

## Notes for the Mechanic

Each clutch spring should be within the limits of 112 to 120 lbs. when compressed to a length of 1⅞ inches. Any spring not within these limits should be replaced. Transmission sliding gears should be marked before dismantling to insure reinstallation in original position. Countershaft cluster should be a free fit in case with no perceptible end play. Make sure that lug on bronze washer "D," Fig. 20, at each end, is aligned with corresponding slots in case. Clutch shaft and mainshaft universal joint flange splines should be coated with Lubriplate or equivalent when assembling.

# Universal Joints

The universal joints are equipped with sealed roller bearings which should be disassembled, cleaned, repacked and fitted with new oil seals at intervals of 30,000 miles.

Fig. 19—Clutch Pedal Should Have 1½ Inches Free Travel. Free Travel is Controlled by the Adjusting Nut "D"

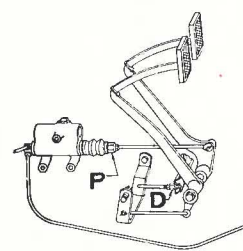
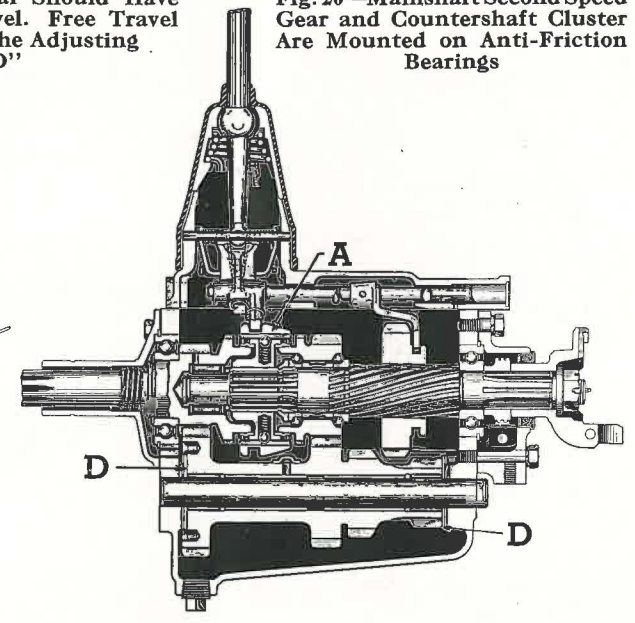

Fig. 20—Mainshaft Second Speed Gear and Countershaft Cluster Are Mounted on Anti-Friction Bearings



## Rear Axle

The rear axle used on Packard cars is a semi-floating unit with hypoid driving gears. Details of the carrier assembly are shown in Fig. 21. The housing cover is welded in place. The driving pinion carries only a bearing adjustment. The pinion mesh position is fixed and non-adjustable. Wheel bearings are semi-permanently lubricated due to the large lubricant reservoir formed by the double oil seals at outer end of each shaft.

The differential housing should be drained every fall, or every 10,000 miles, and refilled with fresh lubricant. A special gear lubricant is required for hypoid gears. See Packard dealer for approved lubricant. This is important. Standard ratio 4.36 on 1601, 4.7 on 1602, optional 4.54.

### Wheel Bearing Adjustment

Axle shaft end play should be .004" to .007" total. Adjustment is by means of shims as shown at "A" in Fig. 22 after unbolting the backing plate and clips holding brake tube to axle housing. End play of less than .050" can be restored to the desired .006" by adjusting at one side only. Adjust both sides if end play is more than .050".

### Notes for the Mechanic

**Pinion Shaft Bearings:** Bearings should be adjusted to a preload drag of 25 to 30 inch pounds. Stated in other words, the self-locking flange nut should be tightened until it buckles the spacer, Fig. 21, sufficiently to require a pull of 5 to 6 pounds (measured on wrench handle 5" out from center of socket) to rotate the pinion shaft.

To adjust preload, draw up the nut until you feel the spacer start to buckle. Check scale pull required to rotate pinion shaft. If pull is less

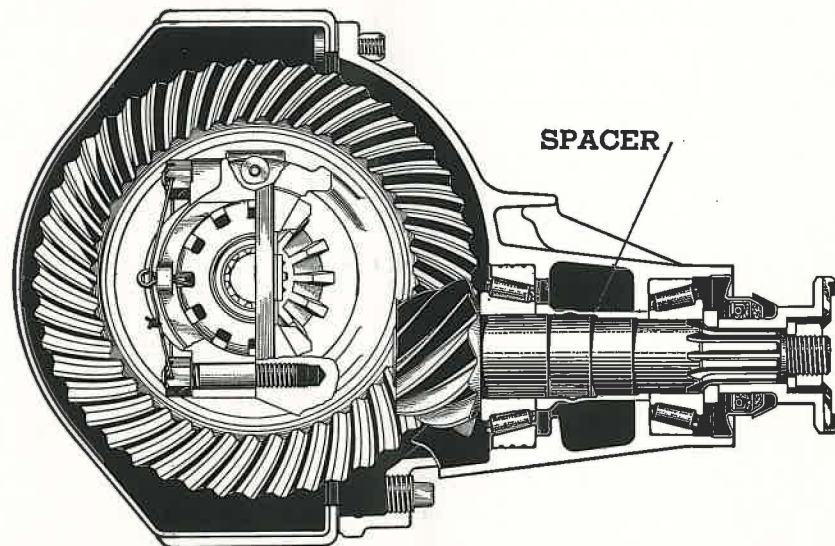

Fig. 21—Rear Axle Differential Carrier Assembly. Note Crimp Near Rear End of Pinion Spacer

than 25 inch pounds, tighten nut further until this amount of drag is secured.

**IMPORTANT:** Readjust the preload, as just outlined, every time the universal flange nut is loosened or removed. Readjust with both wheels jacked off the floor or with carrier removed.

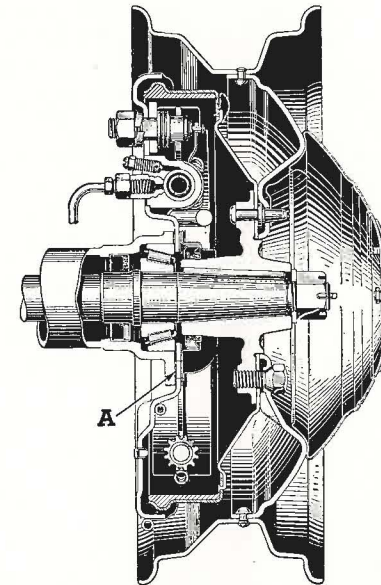

Fig. 22—Rear Wheel Bearings are Shim Adjusted

**Differential side bearings** should be preloaded to a .010" to .012" spread of the bearing support pedestals. To adjust spread, proceed as follows: Loosen each side bearing cap just slightly then back off the right hand (viewed from rear) bearing adjusting nut until ring gear mount is loose in bearings. Make sure that left hand adjusting nut is backed out far enough to provide some backlash between ring and pinion gear. Using a large outside caliper and a .010" feeler blade, caliper from one cap boss to the other with the .010" feeler blade interposed between one of the machined bosses and the caliper. Lock the caliper at this setting. Now tighten the right hand bearing adjusting nut until the previously adjusted caliper (minus the .010" feeler) will just slide over both cap bosses. This gives the desired .010" spread.

Now check backlash between pinion and ring gear teeth. If lash is more than .005" back off the right hand adjusting nut and tighten the left hand nut exactly the same amount until lash is within the .003" to .005" limit. By turning each nut exactly the same amount backlash may be adjusted without disturbing the previously adjusted preload spread. Tighten both caps securely and lock the adjusting nuts.

The fore and aft position of the pinion in the carrier is fixed and non-adjustable.

Pinion shaft splines should be coated with Lubriplate or equivalent when assembling.

# Chassis Suspension

If the front tires show irregular wear or if the car does not "handle" correctly, the toe-in, camber and caster should be checked and corrected if necessary, as outlined in the following paragraphs.

## Toe-in

Recommended toe-in is  $\frac{1}{32}$  to  $\frac{1}{16}$  inch measured at or as near hub height, as possible.

1. Inflate all tires to recommended pressure. Adjust front wheel bearings. Center the steering worm on "high spot" and front wheels straight ahead before measuring. Dimension "X" Fig. 23, from brake backing plate to frame at first rivet back of bumper on left side, should be same within  $\frac{1}{8}$ " as "Y" on right side. If "X" and "Y" are not the same, lengthen the cross tube on short side to make them equal.

2. Spin the front wheels and with a sharpened piece of soapstone or chalk, mark a continuous line on the circumference of each tire at the center of the tread.

3. Measure the distance "B," Fig. 23, at or near hub height then measure the distance "A" at same height at rear of car. Distance "B" should be  $\frac{1}{32}$ " to  $\frac{1}{16}$  inch shorter than "A." Use maximum toe-in with maximum camber and low limit of toe-in when camber is at minimum value. If toe-in is not within these limits adjust as outlined in next paragraph.

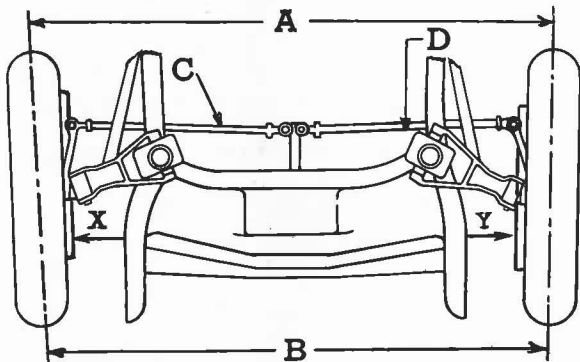

Fig. 23—Correct Toe-in Exists when Distance "B" is  $\frac{1}{32}$ " to  $\frac{1}{16}$ " Shorter Than "A"

4. To adjust toe-in, loosen clamp at each end of both cross tubes. Turn both tubes an equal amount then recheck "A" and "B" repeating this procedure until correct toe-in is secured. Check both cross tubes for length. If one tube is now longer than the other by more than  $\frac{1}{8}$  inch, a bent knuckle arm is indicated.

## Camber

Desired camber angle is  $\frac{1}{2}^\circ$  but a minimum of zero and a maximum of one degree is permissible. Angle should be checked with car loaded as per note below.

Four wheels must be resting on level floor or rack and top of frame side rail on each side at front must be parallel with floor or rack. Height "A," Fig. 24, from floor to top of frame side rail measured with front tires inflated to same pressure must be same on each side within  $\frac{1}{4}$  inch. If not within this limit, replace the short spring.

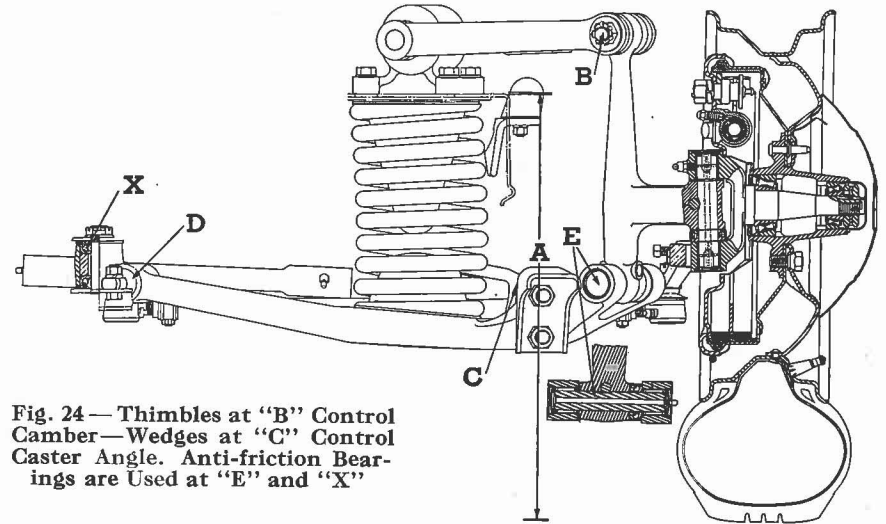

Fig. 24—Thimbles at "B" Control Camber—Wedges at "C" Control Caster Angle. Anti-friction Bearings are Used at "E" and "X"

NOTE: Car is considered loaded with 375 lbs. on rear seat of 5 passenger (675 on 7 passenger) bodies and 300 lbs. on front seat. Load should be 300 lbs. on front seat of coupes and 225 lbs. on auxiliary seats.

Camber is adjusted by installing the proper Packard offset pilot thimbles at shock absorber bolt "B," Fig. 24. Pilots of zero,  $\frac{1}{16}$ ,  $\frac{1}{8}$  and  $\frac{3}{16}$ " offset are available. A change of  $\frac{1}{16}$ " in amount of offset changes the camber angle  $\frac{1}{8}$  of a degree.

## Caster

Desired caster angle is  $1\frac{1}{2}$  degrees but a minimum of one and a maximum of 2 is permissible. Angle should be checked with wheels resting on level floor or rack and car loaded as per note above.

Caster is changed by installing the proper Packard tapered shim between forward end of torque arm and the wheel support arm as shown at "C" in Fig. 24. Shims of one-half and one degree are available. CAUTION: After making a caster correction, make certain there is no binding or strain on either the shock absorber arm bushing "B" or the wheel support arm inner bushing "D," Fig. 24.

## Rear Springs

The rear suspension is by means of low rate semi-elliptic springs, the leaves of which have a cup shaped depression at each end. Cups in some of the leaves are filled with oil-less bronze disks, some with specially compounded rubber disks and some with disks of special lead alloy. The relative softness of the ride is partly controlled by the number and kind of disks in the springs. Do not vary the number except on the advice of your Packard dealer. Both ends of the rear springs are mounted in rubber bushings. **CAUTION:** Spring bolts should **never** be lubricated with oils or grease. If bolts are ever removed or loosened they should not be tightened until the spring is carrying its normal load. Exclusive function of the spring covers is to keep dirt out—they are not filled with lubricant and should **not** be opened.

## Shock Absorbers

Double acting hydraulic shock absorbers are used front and rear. The units should be checked every 10,000 miles and refilled if necessary. **CAUTION:** Never use anything but Packard or Houdaille fluid in shock absorbers on the Packard Eight.

Make sure that roll control bar is tight on rear shock absorber arms as looseness at these points will produce an erratic ride.

## Notes for the Mechanic

If troubled by wheel fight or improper handling, first check steering geometry and the steering gear then the suspension system, as follows:

With car on level floor or rack distance "A", Fig. 24, from floor to top of frame at center of spring should be  $19\frac{1}{4}$  inches plus or minus  $\frac{1}{4}$  inch. Height should be measured with car loaded 375 lbs., on rear seat of 5 passenger, 675 on 7 passenger bodies and 300 lbs., on front seat. Load should be 300 lbs., on front seat of the various coupe bodies and 150 lbs., in rear seat or compartment. Distance from bottom of frame to top of axle, car loaded, should be  $6\frac{1}{4}$  inches plus or minus  $\frac{1}{4}$  inch. Springs must be renewed or otherwise corrected if height is not within these limits.

Steering crank pivot bearing, "X" Fig. 24, should be adjusted to a preload of 4 lbs. measured at ball, with cross tubes and connecting rod disconnected.

Wheel support lower bearing (roller type bearing) should be preloaded to 3 to 8 lbs. pull measured at top of wheel support eye "B", Fig. 24, with king pin, backing plate and bolt "B" removed. Secure this adjustment by adding or removing shims which are available in thickness steps of .001 inch.

Bushings used to support the knuckle king pin are of special oil impregnated bronze. Resize the inside diameter with a burnishing broach, Packard Tool No. S. T.-5046. Never ream these bushings as this method closes the pores of the metal and destroys its self-lubricating characteristics.

Dip torque arm rubbers in soap water before assembling.

## Steering Gear

Preparatory to adjusting the gear, the front road wheels should be jacked up and the steering connecting rod (drag link) disconnected at the crank end. Check freedom of the system by swinging the wheels through their normal turning arc. If "tight spots" are encountered locate and "free up" or renew the tight bearing.

The gear should also be checked for misalignment before proceeding to the actual adjustment. Loosen steering gear to frame bolts enough to permit gear to align itself to the angle determined by height setting of instrument board bracket then retighten the frame bolts securely. Next loosen gear bracket at instrument board so that gear will align itself to the angle determined by the frame bracket. Note this position and if it appears that tightening the instrument board bracket will strain the column shim the bracket or elongate the mounting holes or both if necessary then retighten. The actual adjustments should be made in the order following:

### Column Up and Down Play

1. Turn steering wheel to either stop then back up  $\frac{1}{8}$  turn. Loosen the worm cover screws "A", Fig. 25, about  $\frac{1}{8}$  inch. Remove one thin gasket, being careful not to mutilate the others.

2. Tighten the cover screws "A" and check to see if all play has been removed. When properly adjusted a pull of not less than  $1\frac{1}{2}$  and not more than  $2\frac{1}{4}$  lbs. (measured at rim end of wheel spoke) should be required to move the steering wheel. When executing this test remember that an increase in drag will be encountered, momentarily, as wheel is turned through the "high spot" or mid position. The pull of  $1\frac{1}{2}$  to  $2\frac{1}{4}$  lbs. applies only when gear is **off** the "high spot," with drag link disconnected.

### Cross Shaft End Play

3. Turn steering wheel to either stop then back up  $\frac{1}{8}$  turn. Grip hub of cross shaft lever, Fig. 25, and check end play by feel. Adjust to remove all end play by means of the cross shaft adjusting screw "C".

### Roller Mesh

Turn steering wheel to "high spot" or mid position. Move cross shaft lever back and forth in direction of normal rotation to determine amount of backlash. If any backlash exists at this time, a mesh adjustment will be necessary. Execution of this adjustment requires removal of the cross shaft from gear housing although removal of the gear assembly from the car is the procedure preferred by some mechanics.

**Important:** Since the cross shaft must be removed in either method, it is important to protect the cross shaft oil seal. Protection may be secured by installing a metallic protecting thimble, Packard S. T.-5032, over the splines prior to removal of cross shaft. If this tool is not available, a layer of friction tape must be carefully wound over the splines.

With cross shaft removed, mesh adjustment procedure is as follows:

4. Remove one of the thin cross shaft adjusting shims and reinstall cross shaft temporarily, but do not install the cover plate.

Turn steering wheel nearly to left stop. Hold cross shaft in place with thumb pressure and revolve steering wheel to right (clockwise) until shaft roller is on "high spot" at center of worm. Holding cross shaft in place with thumb pressure grip the splined opposite end and try to rotate it. If any backlash exists, remove another shim and recheck until all backlash is removed. Make sure that bevel on thick thrust washer faces the roller end of cross shaft as shown in Fig. 25.

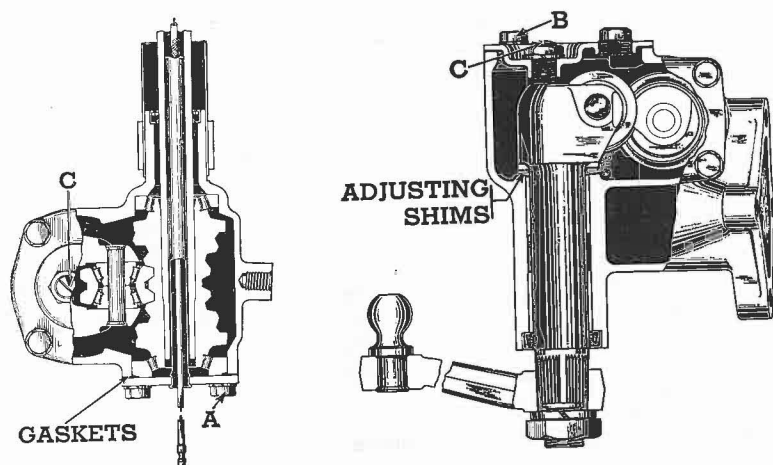

Fig. 25—Steering Gear is of the Integral Housing Type. Bearings Supporting the Column and Cross Shaft Roller Should be Adjusted to a Preload as Outlined in Text. On Some Cars the Roller is Mounted on Ball Bearings Instead of the Roller Type Shown

5. Turn steering wheel to left or right stop then back up  $\frac{1}{8}$  turn. Reinstall the roller shaft cover but before tightening the cover screws "B" back off the cross shaft adjusting screw several turns. After tightening the cover screws adjust cross shaft to zero end play by means of the shaft adjusting screw "C."

Check mesh adjustment by rotating steering wheel through the "high spot" or mid position with drag link disconnected. Adjustment is correct when the pull required to move steering wheel through the "high spot" is not less than 3 and not more than  $4\frac{1}{2}$  lbs. If amount of drag at "high spot" is greater than  $4\frac{1}{2}$  lbs., install a thin shim, if less than 3 lbs., remove a thin shim.

## Brakes

Service brakes are of the single anchor, self-energized type, actuated hydraulically. The parking brake utilizes the rear wheel service shoes which are actuated mechanically by a hand lever through steel cables and an equalizer. The hand lever, equipped with a ratchet mechanism, is attached to the cowl.

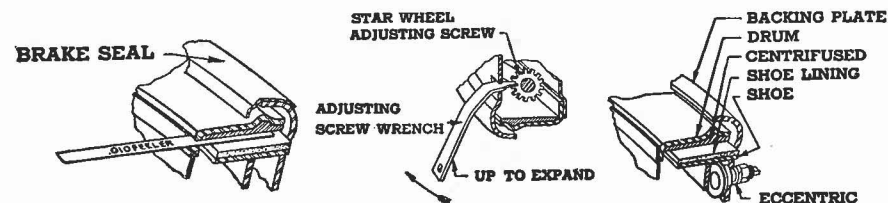

Fig. 26—Left View Shows Method of Checking Lining Clearance with .010" Feeler Blade. Center View Shows Star Wheel Clearance Adjuster which may also be Turned with a Screwdriver. Right Hand View Shows Outer End of Eccentric in Contact with Brake Shoe

### Service Wear Adjustment

Adjustment to compensate for normal lining wear is accomplished as follows:

1. Jack up all 4 corners of car and remove wheels. Place hand brake lever in fully released position. If doubtful regarding full release of hand brake, remove either one of the hand brake cable clevis pins "A," Fig. 27. Remove adjusting hole covers "C" from backing plates and covers from drum ports.

2. Execute the following adjustments at each wheel.

- a. Insert a .010 inch feeler blade between lining and drum at lower end of secondary shoe (rear shoe) and turn eccentric "E" towards front of car until feeler is just firmly gripped. Holding this position, tighten the lock nut on eccentric.

- b. Turn star wheel adjuster "B" by using a screwdriver or special tool through port "C" until slight drag is felt then back off until drum is just free when turned. Reinstall all wheels and inspection covers.

### Service Major Adjustment

Whenever the shoes are relined or whenever the "wear" adjustment fails to give satisfactory results, the major adjustment outlined below should be executed.

1. Jack up all 4 corners of car and remove wheels. Place hand brake lever in fully released position. If doubtful regarding full release of hand



brake, remove either one of the clevis pins "A," Fig. 27. Remove adjusting hole covers "C" from each backing plate and also from the drum port at each wheel.

2. Execute the following adjustments at each wheel.

a. Insert a .010 inch feeler blade between lining and drum at lower end of secondary shoe (rear shoe) and turn eccentric "E," Fig. 27, towards front of car until feeler is just firmly gripped. Tighten lock nut on eccentric.

b. Loosen the lock nut on anchor "D" one turn. Insert .010 inch feeler blade between lining and drum at the upper end of the rear (secondary) shoe and turn anchor in desired direction until .010 inch feeler is just firmly gripped. Holding this position tighten anchor lock nut securely with a wrench 12 to 16 inches long.

Clearance at both ends of secondary (rear) shoe should be .010".

c. Turn star wheel adjuster "B" until slight drag is felt then back off until drum is just free when turned. Reinstall wheels and covers.

## Hand Brake Adjustment

1. Jack up rear wheels. With equalizer against its stop and lever fully released, remove slack from lever to equalizer cable by turning the clevis at equalizer end of cable.

2. Remove clevis pin from equalizer end of each brake pull cable. Expand rear wheel shoes by turning star wheel adjuster until each rear wheel can just be turned with both hands.

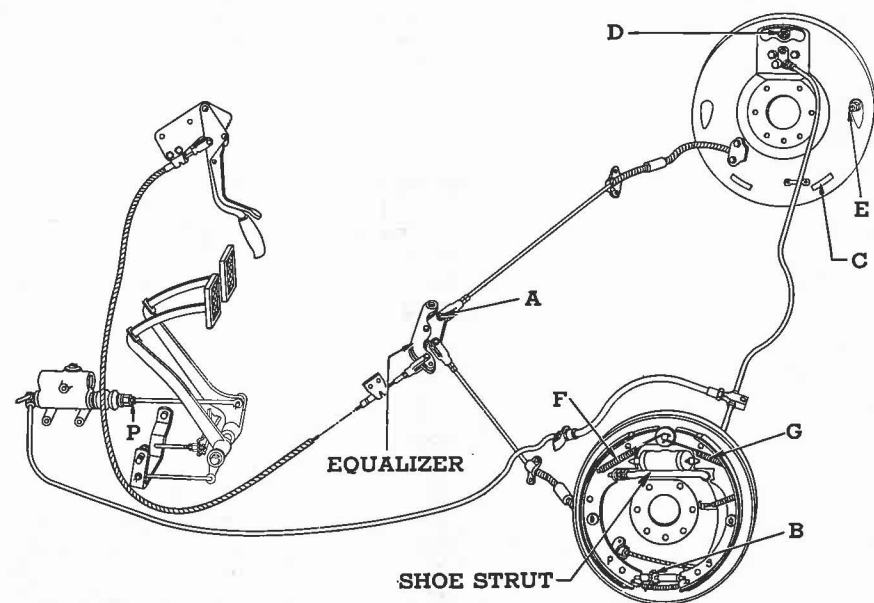

Fig. 27—Chassis Brake Diagram. Clearance Adjuster is Shown at "B", which is Accessible Through "C." Anchor Pin is Shown at "D" and Eccentric at "E"

Set hand brake lever in first notch. Place equalizer bar in even pulling position at right angles to frame side rails. Adjust length of each pull cable so that clevis pins will just enter freely without moving the equalizer bar. Insert and cotter the clevis pins. Release hand lever. Back off star wheel adjuster until both rear wheels are just free of drag.

3. Get final equalization on testing machine or floor by backing off star wheel adjuster at "tight" wheel.

## Bleeding the Lines

Whenever the brakes have a "spongy" action or if the main outlet pipe from master cylinder has been disconnected the system must be bled at all 4 wheels. If a line is disconnected from any one wheel cylinder, only that cylinder must be bled. Procedure is as follows:

Remove screw from bleeder connection at backing plate side of wheel cylinder and attach bleeder tube. Place opposite end of tube below the liquid level in clean glass jar partially filled with brake fluid. Fill the master cylinder reservoir with genuine Packard fluid and keep reservoir at least half full during the bleeding operation. If Packard fluid is not available, use Lockheed No. 5 fluid.

Open bleeder valve  $\frac{3}{4}$  of a turn and depress the brake pedal slowly by hand. Allow pedal to return slowly to prevent entrance of air. A second person should observe the bleeder hose. Continue this action until fluid passing from hose shows no air bubbles, then tightly close the bleeder valve. Repeat this operation at other 3 wheels if necessary.

Fluid withdrawn in the bleeding operation should not be used again. Check fluid level in master cylinder reservoir after bleeding each cylinder and refill if less than half full.

## Pedal Free Movement

The master cylinder primary cup must clear the small by-pass port when the piston is in released position. If cup does not clear the by-pass port, the compensating action of the master cylinder will be destroyed and the brakes will drag after several applications. To prevent this trouble the brake pedal push rod should be adjusted to provide  $\frac{1}{4}$ " free initial travel of the pedal. Adjustment is by means of the push-rod adjusting nut "P" shown in Fig. 27.

## Tires

Wheels are equipped with 7.00 x 16 4-ply balloon tires. These tires are balanced and marked with a red dot to indicate the proper location for the valve stem of the inner tube. Thus the relative positions of the tire and tube are fixed to insure the best assembly balance. Front tires on the 1601 should be inflated to 22 pounds, rears to 23 pounds, cold. On the 1602 front tire pressure should be 24 pounds, rear 27 pounds, cold. Cold as used here means at atmospheric temperature.

## Hearse Chassis — 1601-A

Adjustment Data on this model same as 1601 except the following:

Tire size.....	7.00 x 16—6 ply
Tire pressure.....	26 lbs. front—cold 33 lbs. rear—cold
Tire carrier.....	Right side
Rear axle ratio.....	4.54—1
Maximum load including body.....	2500 lbs
Turning radius.....	25' 8"

## Number Information

**Engine Number**—Stamped on boss, upper rear left side of block. The engine number is the principal identifying number and should always be used when ordering parts.

**Vehicle Number**—Stamped on transfer attached to front of dash. The vehicle number is stamped on the transfer before the car leaves the factory, but the delivery date, the name of the distributor or dealer making the delivery, and the city are stamped on the transfer at the time of delivery to customer.

The delivery date is of particular importance because it establishes the age of the car for insurance purposes. **Be sure that the delivery date is stamped on your car.**

**Body Serial Number**—Embossed in left front face of dash.

This is used as final reference where the other numbers have been altered. It is an additional protective measure.

## Ordering Parts

It is advisable to make all parts replacements with Packard Precision Built Parts which may be procured from authorized dealers.

**When ordering specify:** Shipping directions; engine number; vehicle number; complete description of part; color, if part is painted.

All quotations are subject to change without notice.

All parts should be ordered from the nearest Packard distributor or dealer. Orders sent direct to the factory will be shipped C. O. D., F. O. B. shipping point, unless accompanied by cash. Our responsibility ceases when goods are delivered in good condition to transportation company.

